



MULTI-BLADE LOW LEAKAGE FIRE DAMPERS
AIRFOIL BLADES • GALVANIZED OR STAINLESS STEEL
USCG TYPE APPROVED FOR CLASS A-60 DIVISIONS
MODELS: 1201-MDG AND 1201-MDS

APPLICATION:

Models 1201-MDG (galvanized) and 1201-MDS (stainless steel) are multi-blade low leakage fire dampers for use in marine applications which require USCG approval for installation in Class A-60 divisions.

QUALIFICATIONS:

- International Maritime Organization Fire Test Procedures Code USCG Type Approval A-60. Approval Number 164.139/8/0.
- European Wheel Mark  1408/05.
- Southwest Research Institute Test report No. 01.10933.01.701.
- Leakage: Less than 4 cfm/sq. ft. @ 1" w.g.

STANDARD SPECIFICATION:

- FRAME:** 5" x 7/8" x 16 ga. (127 x 22 x 1.6) galvanized or stainless steel hat channel.
- BLADES:** 14 ga. (2.0) equivalent galvanized or stainless steel formed airfoil on 5 1/2" (140) centers. Opposed blade action.
- LINKAGE:** Concealed in frame. 12 ga. (2.7) plated or stainless steel.
- AXLES:** 1/2" (13) dia. plated or stainless steel double bolted to blade.
- BEARINGS:** 1/2" (13) dia. self-lubricating oilite bronze or sintered stainless steel.
- JACKSHAFT:** 1/2" (13) dia. plated or stainless steel. CCW rotation to open.
- JAMB SEALS:** Stainless steel.
- FUSIBLE LINK:** 165°F (74°) standard.
- SLEEVE:** 12" (305) long x 16 ga. (1.6) with 2" (51) flange on both ends. 10" (254) through 24" (610) long and 16 ga. (1.6) through 10 ga. (3.51) available. 12" (305) min. with MLS-300. Flange widths from 1" (25) to 3" (76) available.
- MINIMUM SIZE:** Vertical or Horizontal mount: 8" x 8" (200 x 200).
- MAXIMUM SIZE:** Single Section
Vertical or Horizontal mount: 36" x 36" (915 x 915).
Multiple Section Assembly
Vertical or Horizontal mount: 72" x 36" (1830 x 915).

BASE MODEL SELECTION:

- 1201-MDG Galvanized construction.
- 1201-MDS Type 304 Stainless Steel construction.
- 1201-MDS Type 316 Stainless Steel construction.

SLEEVE SELECTION:

SLEEVE LENGTH AND GAUGE:

- Standard 12" (305) long x 16 ga. (1.6).
- Non-standard. Specify: ___ inches (mm) x ___ ga.

SLEEVE FLANGE:

- Standard 2" (51) flange.
- Non-standard flange. Specify: ___ inches (mm).

ACTUATOR SELECTION:

- Electric Pneumatic Model: _____.
- HLQ Hand locking quadrant

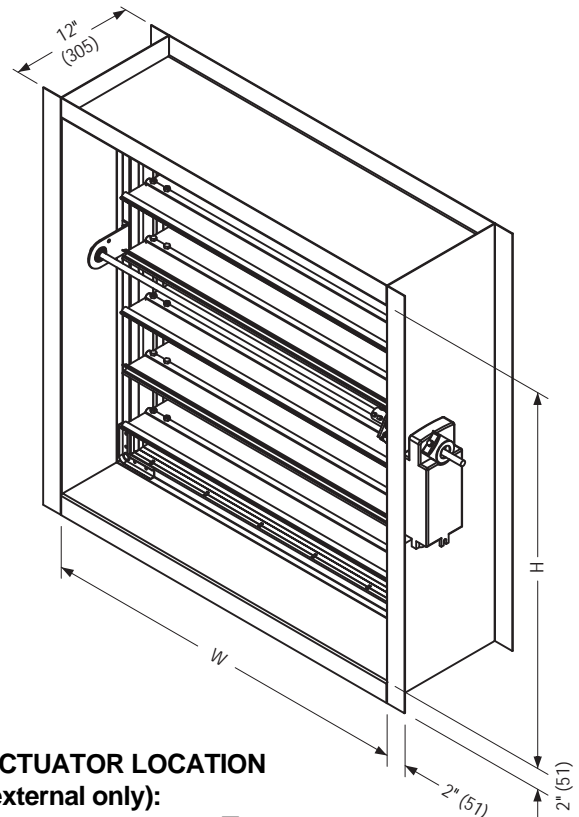

ACTUATOR LOCATION (external only):

- Right hand (std.) Left hand

ACTUATOR FAIL POSITION:

- Closed (std.) Open

OPTIONS:

- CWS Continuous weld sleeve
- 300 MLS-300 position indicator package
- 212 212°F (100°C) fusible link.

ACTUATORS

MODEL	SUPPLY (VOLTAGE OR PSI)	APPLICATION
MS4X09 MS8X09 MS4Y09 Honeywell FATPA HT 80 lb. - in.	120 VAC 24 VAC 230 VAC	Single Section (Fail Closed)
MS4120F MS8120F MS4620 Honeywell FATPA XT 175 lb. - in.	120 VAC 24 VAC 230 VAC	Single Section (Fail Closed or Open) or Multi-Section (Fail Closed)
331-4826 Siemens #3 8 - 13 psi spring	25 psi	Single Section (Fail Closed)
331-2961 Siemens #4 8 - 13 psi spring	25 psi	Multi-Section (Fail Closed)

Actuators are externally mounted only.
Additional actuators available. Contact factory.

Dimensions are in inches (mm).

SCHEDULE TYPE:				
PROJECT:				
ENGINEER:	DATE	B SERIES	SUPERSEDES	DRAWING NO.
CONTRACTOR:	8 - 21 - 12	1200	6 - 7 - 06	1201-MDG

Powers™ Controls No. 4 Pneumatic Damper Actuator

Product Description

The No. 4 Pneumatic Damper Actuator is a totally enclosed pneumatic piston type actuator designed to actuate dampers for ventilating systems, mixing box control, and other applications requiring a large, effective diaphragm area and long stroke. The No. 4 Hesitation Actuator is frequently used to operate the outdoor air damper on unit ventilators.

Product Numbers

See Table 1.

Prerequisites

- Ensure all kits are ordered and available for installation. Kits are listed with each mounting application.
- Have the damper manufacturer drill the mounting holes.
- Have the damper manufacturer weld the mounting lug to the damper frame in frame mounting installations.



WARNING:

Do not remove the jam nut (Figure 1). Spring is under heavy load. Repair by trained personnel only.

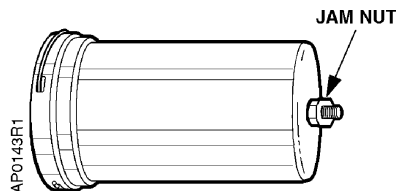

Figure 1. Actuator Jam Nut Location.

Required Tools

- Flat-blade screwdriver
- Adjustable crescent wrench
- Pliers

Warning/Caution Notations

WARNING		Personal injury/loss of life may occur if the user does not follow a procedure as specified.
CAUTION		Equipment damage, or loss of data may occur if the user does not follow a procedure as specified.

Installation

Extended Shaft Mounting-Pivot Actuator

Expected Installation Time: 28 minutes

Actuators: 331-3000, 331-3001, 331-3002, 331-2973, or 331-3004.

These assemblies are designed for 90° damper rotation.

NOTE: Clevis mounts in Crank Radius Hole No. 1 for 90° damper rotation.

1. Slip 3/4-inch (19 mm) diameter hole in the mounting plate over the damper shaft (Figure 2).

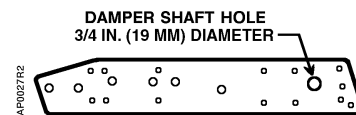

Figure 2. Actuator Mounting Plate.

2. Slip the crank over the 3/8 through 1/2-inch (10 through 13-mm) diameter damper shaft (Figure 3).

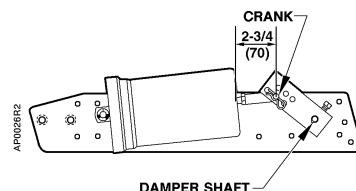

Figure 3. Extended Shaft Mounting.

3. Position the mounting plate and attach it to the duct with four screws.

Table 1. No. 4 Damper Actuator Product Numbers.

Description	Mounting Style	Product Numbers				
		Nominal Spring Range				
		3-7 psi (21-48 kPa)	3-13 psi (21-90 kPa)	5-10 psi (35-69 kPa)	8-13 psi (55-90 kPa)	2-3, 8-13 psi (14-21, 55-90 kPa) Hesitation Model
Actuator, mounting screws (non-pivot)	Front	331-2910	—	331-2917	331-2963	—
Actuator, bracket (non-pivot) 3-inch stroke for unit ventilator	Fixed	331-2911	—	331-2934	331-2966	331-2927
Actuator, bracket (non-pivot) 2-3/8 inch stroke for unit ventilator	Fixed	—	—	—	—	331-2974
Actuator, mounting plate, ball joint connector	Fixed	331-3015	331-3018	331-3016	331-3017	331-3019
Actuator, mounting plate, ball joint connector with positioning relay	Fixed	—	—	—	332-3017	—
Actuator, integral pivot	Pivot	331-2904 ¹	331-2905 ¹	331-2906 ¹	331-2961 ¹	331-2909 ¹
Actuator, integral pivot, clevis and clevis pin for use with frame mounting accessory	Pivot	331-2929	331-2930	331-2931	331-2968	—
Actuator, integral pivot with pivot post ²	Universal kit	331-3000	331-3001	331-3002	331-2973 ¹	331-3004
Actuator, integral pivot with pivot post, and positioning relay ²	Universal kit with positioning relay	—	—	—	332-2973	—

¹ UL Recognized Components for Fire/Smoke Applications.

² Mounted on plate for extended shaft with clevis and crank for 3/8-inch (10-mm), 7/16-inch (11-mm), or 1/2-inch (13-mm) diameter shaft. Parts for frame mounting (blade drive) are included with kit.

NOTE: When the actuator is ordered with universal mounting, the mounting plate, pivot post and hardware, clevis, damper crank, rocker arm, and all screws/nuts are included. Order other frame mounting accessories as required if not supplied by damper manufacturer.

Installation, Continued

Extended Shaft Mounting-Fixed Actuator

Expected Installation Time: 28 minutes

Actuator with mounting bracket: 331-2911,
 331-2966, 331-2934, 331-2927, or 331-2974

Clevis: 331-801

Linkage Kit: 331-958

1. Determine the application from Table 2 and then select appropriate "X" and "Y" dimensions. Select a rigid section of the duct, if possible, and draw these lines on the duct.



CAUTION:

It is important to use the "X" and "Y" dimensions from Table 2 to position the actuator to ensure that the crank is approximately perpendicular to the actuator shaft at half its stroke (see Figure 4). This will prevent the linkage from scissoring or locking up.

Table 2. Fixed Mounted Assembly Dimensions.

Application	Dimensions in Inches (mm)		Crank Radius Hole
	X	Y	
4-inch (102 mm) Stroke – 90° Rotation	8-1/2 (216)	2 (51)	1
4-inch (102 mm) Stroke – 70° Rotation	8-1/2 (216)	3 (76)	2
3-inch (76 mm) Stroke – 90° Rotation	8 (203)	1-1/2 (38)	3
3-inch (76 mm) Stroke – 60° Rotation	8 (203)	2-1/2 (64)	4

NOTE: Crank Radius Holes No. 5 and 6 are used for No. 3 Pneumatic Damper Actuators only.

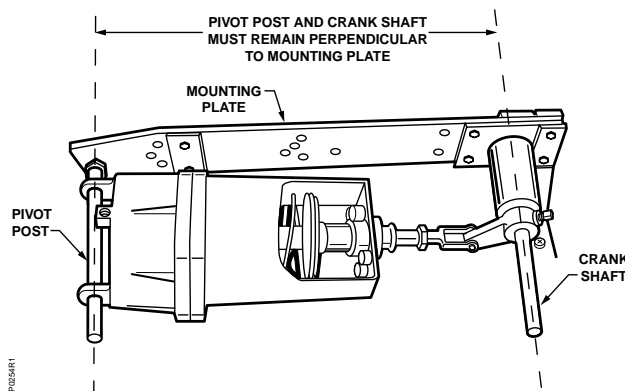

Figure 4. Perpendicular Mounting.

2. Place front of actuator on "X" dimension line so that the actuator shaft faces damper shaft. Place center line of actuator over "Y" dimension line (see Figure 5).
3. Thread Clevis 331-801 on to actuator shaft and tighten against locknut. Assemble Linkage Kit 331-958 to actuator assembly (see Figure 4). The linkage is assembled so that the damper shaft will rotate counterclockwise as actuator pressure increases. This is a typical normally closed damper installation.

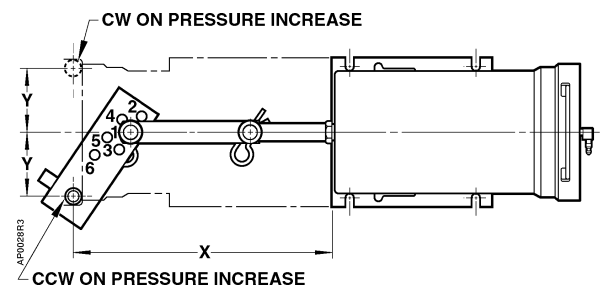

Figure 5. Fixed Mounted Actuator Assembly.

Frame Mounting

Expected Installation Time: 3 hours

Actuator: 331-3000, 331-3001, 331-3002, 331-2973,
 or 331-3004.

Mounting lug: 331-569

1. If the damper frame is aluminum, light gauge sheet metal, or an unusual shape, bolt a 3/16-inch (5 mm) thick, flat piece of steel to the frame where the mounting lug is to attach. The mounting lug can then be welded to it.
2. Weld the mounting lug parallel and 5/16-inch (8 mm) from the inside edge of the damper frame and perpendicular to it (Figure 6). Weld the lug along both sides. The lug should be as close as possible to the corner of the damper frame to minimize deflection. The damper manufacturer should weld the lug.
3. If the damper frame is aluminum, light gauge sheet metal, or an unusual shape, bolt a 3/16-inch (5-mm) thick, flat piece of steel to the frame. Then, weld the mounting lug to the piece of steel.

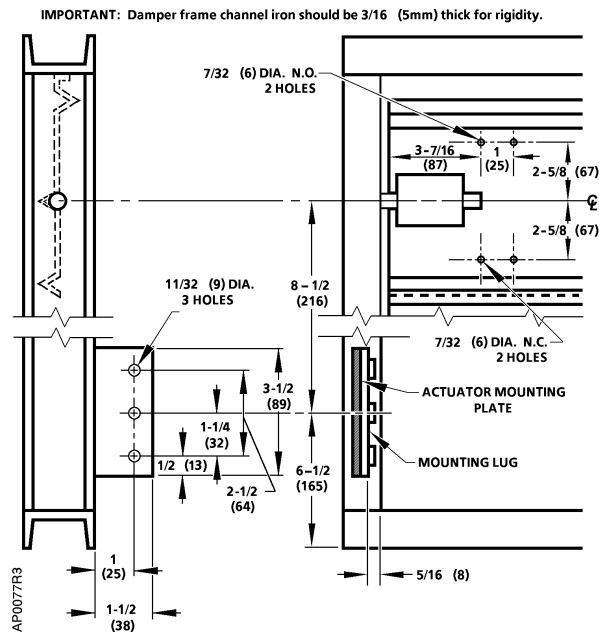

Figure 6. Frame Mounting Dimensions.
 Dimensions in Inches (Millimeters).

4. Attach rocker to blade in proper position for normally open or normally closed damper (Figure 6).
5. Attach mounting plate to mounting lug.
 - a. Normally closed damper: attach plate to lug (Figure 7). Place pivot post in Hole 3.

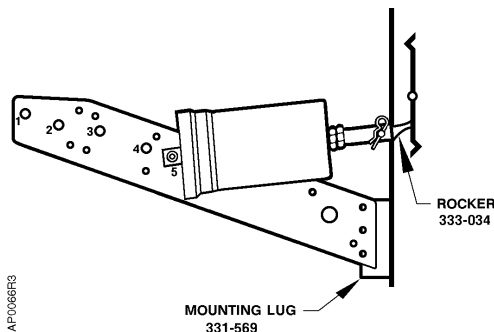

Figure 7. No. 4 Actuator Frame Mounting,
 Normally Closed Damper.

- b. Normally open damper: attach plate to lug (Figure 8). Place pivot post in Hole 6.

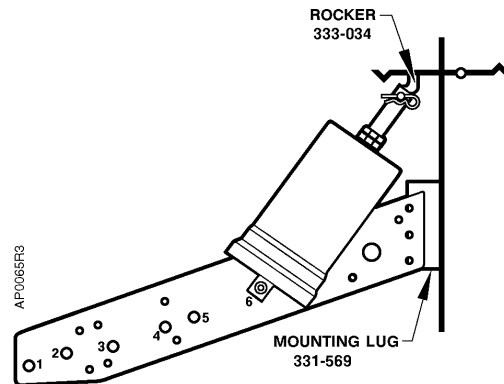

Figure 8. No. 4 Actuator Frame Mounting,
 Normally Open Damper.

6. Fasten clevis to rocker. Discard crank and other parts not used.
7. The actuator mounting plate has a tendency to pivot at the point where the lug is welded to the damper frame when the actuator strokes. It is recommended that some means be devised in the field to prevent this from happening. A threaded rod attached to the mounting plate and duct wall will normally work.

Hesitation Actuator Adjustment

Expected Installation Time: 15 minutes

1. To obtain an initial hesitation point, add air pressure to actuator until shaft travels the desired distance.
2. Turn locknuts on cycle adjustment rods until they contact lower housing and then lock together. Tighten cycle adjustment nuts evenly to ensure smooth operation.

The installation is now complete.

References

AP 331-2 Powers™ Controls No. 4 Pneumatic Damper Actuator Technical Instructions, (155-032P25)

TB 181, Maximum Thrust Ratings of Pneumatic Damper Actuators Technical Bulletin, (155-219P25)

Information in this publication is based on current specifications. The company reserves the right to make changes in specifications and models as design improvements are introduced. Other product or company names mentioned herein may be the trademarks of their respective owners. © 2002 Siemens Building Technologies, Inc.

POWERS™ Controls

No. 3 Pneumatic Damper Actuator

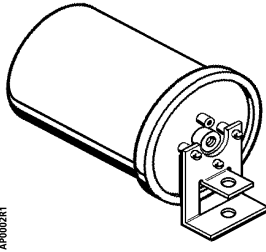

AP00021

331-4312 Pivot Mounting

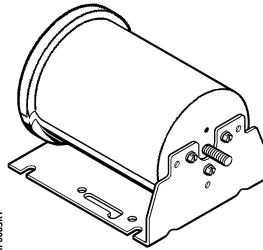

AP00021

331-4313 Fixed Mounting

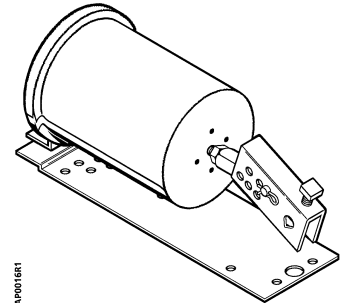

AP00021

331-4311 Extended Shaft Mounting

Description

The POWERS Controls No. 3 Pneumatic Damper Actuator is a compact, totally enclosed, rolling diaphragm-type actuator designed for modulating or two-position actuation of dampers or air valves.

Features

- All metal body construction
- Totally enclosed to protect internal parts
- Variety of spring ranges for sequencing
- Fixed or pivot mounting models
- Pivot mounting for extended shaft
- Positioning relay (optional)
- Variety of mounting/linkage kits for special applications
- Threaded shaft for easy mounting to accessory thread

Product Numbers

See Table 1.

Application

Typical applications are for control of mixing box dampers or air valves, and damper control for unit ventilators, unit conditioners and other HVAC applications.

These compact, totally enclosed actuators are easily installed either directly within the mixing box or unit enclosure, or externally, as required for each application.

Table 1. Product Numbers for No. 3 Pneumatic Damper Actuators.

Description	Mounting Style	Part No.		
		Nominal Spring Range		
		3-7 psi (21-48 kPa)	5-10 psi (35-69 kPa)	8-13 psi (55-90 kPa)
Actuator	Front	331-4310	331-4510	331-4810
Actuator, bracket	Fixed	331-4313	331-4513	331-4813
Actuator, bracket, clevis	Fixed	331-4314	331-4514	331-4814
Actuator, integral pivot	Pivot	331-4312	331-4512	331-4812
Actuator, integral pivot with pivot post *	Extended shaft	331-4311	331-4511	331-4811
Actuator, integral pivot with pivot post *	Extended shaft kit with positioning relay	—	—	332-4811
Actuator, bracket, ball joint connector	Fixed	331-4331	331-4531	331-4831
Actuator, bracket, ball joint connector and positioning relay	Fixed	—	—	332-4831
Extended shaft with 90° barb fitting (for fume hood controller applications)	Extended shaft	—	—	546-00020

* Mounted on plate for extended shaft with clevis and crank for 3/8-inch (10-mm), 7/16-inch (11-mm), or 1/2-inch (13-mm) diameter shaft.

NOTE: When the actuator is ordered with extended shaft mounting, the mounting plate, pivot post and hardware, clevis, damper crank, rocker arm, and all screws/nuts are included. Order other frame mounting accessories as required if not supplied by damper manufacturer.

Specifications		
Effective diaphragm area		8 inches ² (51.6 cm ²)
Stroke		2-3/8 inches (6 mm) *
Housing (totally enclosed)		Aluminum
Stem		Plated steel
Diaphragm		Ozone resistant rubber
Spring		Steel
Cup		Zytel
Maximum air pressure		30 psig (210 kPa)
Type of mounting		Fixed or pivot
Thrust and torque rating		See Table 3
Agency Approvals		Complies with UL555 and UL555S
	* For special applications, an actuator stroke of 2-3/4 inch is available in 3 to 7, 5 to 10, or 8 to 13 psi (21 to 58, 35 to 69, or 55 to 90 kPa) spring ranges. Some models are UL Recognized Components under UL's Damper Actuator category (EMKU2), which covers pneumatic damper actuators intended to be employed on fire dampers and leakage rated dampers. Contact Siemens Building Technologies, Inc. National OEM Sales and Marketing for information.	

**Specifications,
 Continued**

Operating

Nominal spring ranges	3 to 7 psi (21 to 50 kPa) 5 to 10 psi (35 to 69 kPa) 8 to 13 psi (55 to 90 kPa)
Operating temperature	-20°F to 160°F (-29°C to 71°C)
Air connection	Straight barb fitting for 1/4-inch OD plastic tubing installed in 1/8-inch NPT opening

Miscellaneous

Shipping Weight:	
Basic actuator	1.3 lb (0.58 kg)
Actuator with extended shaft mounting	3.1 lb (1.4 kg)
Actuator with fixed bracket	2.5 lb (1.1 kg)
Actuator with fixed bracket and clevis	2.7 lb (1.2 kg)
Actuator with extended shaft mounting and Positioning Relay	4.8 lb (2.2 kg)
Dimensions	See Figures 4 through 8

Accessories

Linkage kit, 4-inch link and crank	331-958
Linkage kit, 4-inch rod, ball joint and crank	331-947
Damper shaft crank, selectable radius, 45°, 60°, and 90°, angular rotation for 3/8 to 1/2-inch (10 to 13-mm) diameter damper shafts	331-941
Damper shaft crank, adjustable radius 3/4 to 2-7/8 inch (19 to 73 mm) for 1/2-inch (13-mm) diameter damper shafts	331-795
Damper shaft crank, adjustable radius 3/4 to 4-5/8 inch (19 to 177 mm) for 3/8-inch (9 mm) diameter damper shafts	331-805
Damper shaft extension, 1/2 x 9 inches long	333-042
Damper shaft extension, 1/2 inch shaft	331-631
Damper shaft extension Adapter, for 3/8 inch shaft	331-632
Pivot mounting kit (bracket and three mounting screws)	333-148
Pivot post	333-139
Fixed mounting bracket	331-916
Extended shaft mounting plate	331-033
Clevis, steel	333-207
Clevis, forged	331-292
Clevis pin	331-293
Clevis, frame mounting	331-653
Hitch pin	331-807
12-inch Damper actuator push rod	338-041
15-inch Damper actuator push rod	338-042
18-inch Damper actuator push rod	338-043
24-inch Damper actuator push rod	338-044
36-inch Damper actuator push rod	338-045
48-inch Damper actuator push rod	338-046
Damper blade rocker arm	333-034
Positioning relay	147-2000
Relay mounting kit	147-104

Table 3. Thrust Torque Ratings.

Nominal Spring Range	Maximum Thrust lb. (N)				Torque Rating* lb-in (Nm)			
	Full Stroke Forward			Spring Return (No Stroke) 0 psig (0 kPa)	Gradual Operation	2-Position Operation		
	15 psi (103 kPa)	18 psi (124 kPa)	25 psi (172 kPa)			15 psi (103 kPa)	18 psi (124 kPa)	25 psi (172 kPa)
3 to 7 psi (21 to 48 kPa)	64 (285)	88 (391)	144 (641)	24 (107)	10 (1.1)	20.2 (2.3)	20.2 (2.3)	20.2 (2.3)
5 to 10 psi (35 to 69 kPa)	40 (178)	64 (285)	120 (534)	40 (178)	10 (1.1)	33.6 (3.8)	33.6 (3.8)	33.6 (3.8)
8 to 13 psi (55 to 90 kPa)	16 (71)	40 (178)	96 (427)	64 (285)	10 (1.1)	53.8 (6.1)	53.8 (6.1)	53.8 (6.1)

* With maximum hysteresis of 2.5 psi (17.2 kPa) @ 90° rotation.

Sizing

The size and quantity of actuators required depends on several damper torque factors:

- Damper type (standard or low leakage)
- Quality of damper installation
- Number of damper sections
- Air velocity
- Static pressure
- Age of damper

To determine the correct actuator required for the installation:

- Obtain the damper torque ratings (lb-in/sq-ft) from the damper manufacturer.
- Determine the area of the damper.
- Calculate the total torque required to move the damper.
- Select the appropriate actuator(s).

Installation

Extended Shaft Mounting, Pivot Mounting

For Actuators 331-4311, 331-4511, 331-4811, or 332-4811. These assemblies are designed for 90° damper rotation.

NOTE: Clevis mounts in Crank Radius Hole No. 6 for 90° damper rotation.

1. Slip the 9/16-inch (14 mm) diameter hole in the mounting plate over the damper shaft (Figure 1).
2. Slip the crank over the 3/8 through 1/2-inch (10 through 13-mm) diameter damper shaft (Figure 2).
3. Position the mounting plate (Table 3).
4. Attach the mounting plate to the duct with four screws.

Installation, Continued

Table 3. Damper Blade Rotation.

Actuator Position in Relation to Damper Shaft	Crank Position in Relation to Damper Shaft	Rotation of Damper Blade on Increase of Pressure
Left	Above	Clockwise
	Below	Counterclockwise
Right	Above	Counterclockwise
	Below	Clockwise

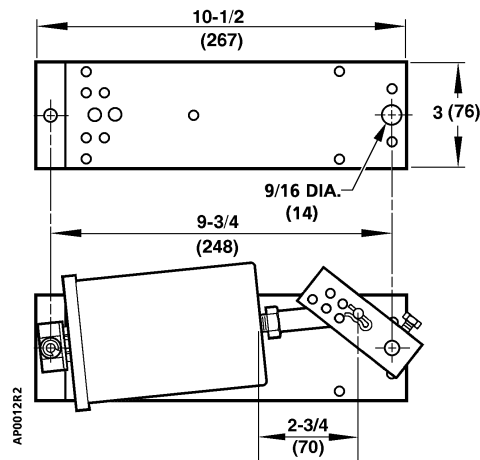
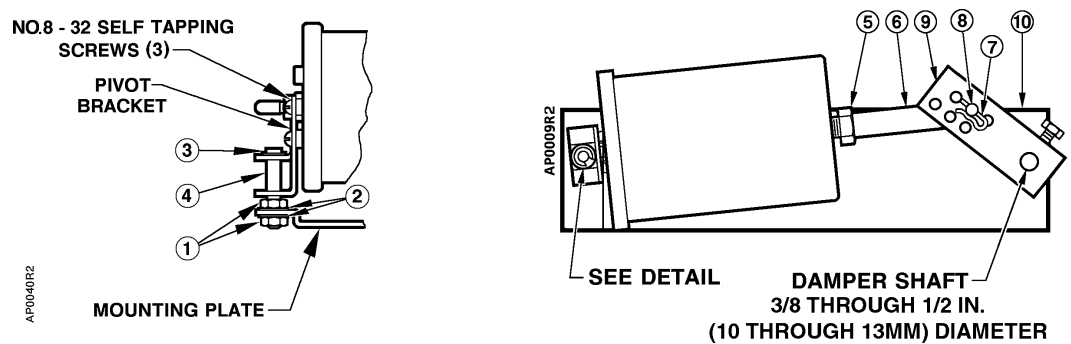

Figure 1. Mounting Plate and Extended Shaft Mounting.



Item	Description	Item	Description
1	Nut(s)	6	Clevis
2	Lock Washers (2)	7	Hitch Pin
3	E-ring	8	Clevis Pin
4	Pivot Post	9	Crank Assembly Kit No. 331-941
5	Nut	10	Actuator Mounting Plate

Figure 2. Extended Shaft Mounting with Pivot.

Installation, Continued

Extended Shaft Mounting, Fixed Actuator

For Actuators 331-4314, 331-4514, 331-4814 order Linkage Kit 331-958.

For Actuators 331-4313, 331-4513, 331-4813, order Clevis 333-207 and Linkage Kit 331-958.

1. Determine the direction of the damper shaft rotation (clockwise or counterclockwise) on an increase in pressure to the actuator.
2. Determine the angle of rotation required for the damper to move from closed to full open.

NOTE: Since the actuator stroke is 2-3/8 inch (6 cm) and the angle of rotation is known, the crank radius can be determined from the graph in *TB181 Maximum Thrust Ratings of Pneumatic Damper Actuators Technical Bulletin* (155-219P25) or use Table 4.

3. Attach the link to the crank at the radius value determined in Step 2.
4. Attach the clevis and other end of the linkage to the actuator shaft (Figure 3).
5. The normal position of the damper (open or closed) and its direction of rotation (CW or CCW) will determine the location of the actuator and linkage assembly (Table 3).
6. Attach an air line or Baumanometer (squeeze bulb) to the actuator and increase pressure until the actuator shaft moves one half of its stroke, 1-3/16 inch (3 cm). Select the correct location for the actuator assembly as determined in Step 5.
7. Slip the crank over the damper shaft and position the assembly so that the actuator shaft and link are straight and perpendicular to the crank.
8. Mark and attach the actuator bracket to the duct at this location. If this installation procedure is followed, there will be no problem with linkage scissoring or locking up.

The installation is complete.

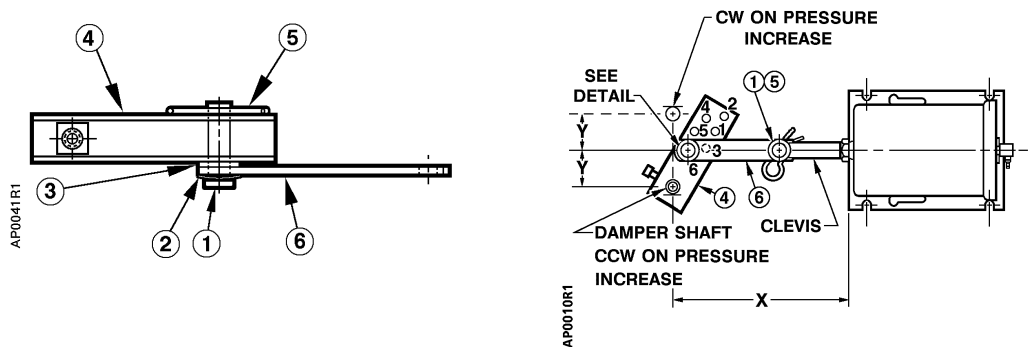

Item	Description	Item	Description
1	Clevis Pin	4	Crank with Set Screw
2	Spring Washer	5	Hitch Pin
3	Washer, Nylon	6	Link, 4 inches (102 mm) long

Figure 3. Fixed Mounted Actuator Assembly with Linkage Kit 331-958.

Installation, Continued

Table 4. Crank Radius Connection.

Dimensions		Application	Crank Radius Connection	Crank Hole Number
X	Y			
7-7/8 inch (200 mm)	1-3/16 inch (30 mm)	2-3/8 inch (60 mm) stroke 90 ° Rotation	1-11/16 inch (43 mm)	6
7-7/8 inch (200 mm)	2-1/16 inch (52 mm)	2-3/8 inch (60 mm) stroke 60 ° Rotation	2-3/8 inch (60 mm)	5

NOTE: Crank Radius Holes No. 1 through 4 are used for No. 4 and No. 6 Pneumatic Damper Actuators only.

Dimensions

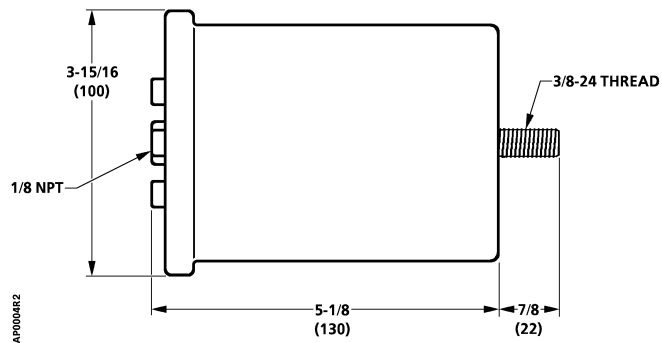

Figure 4. No. 3 Pneumatic Damper Actuator Dimensions. Dimensions are in Inches (Millimeters).

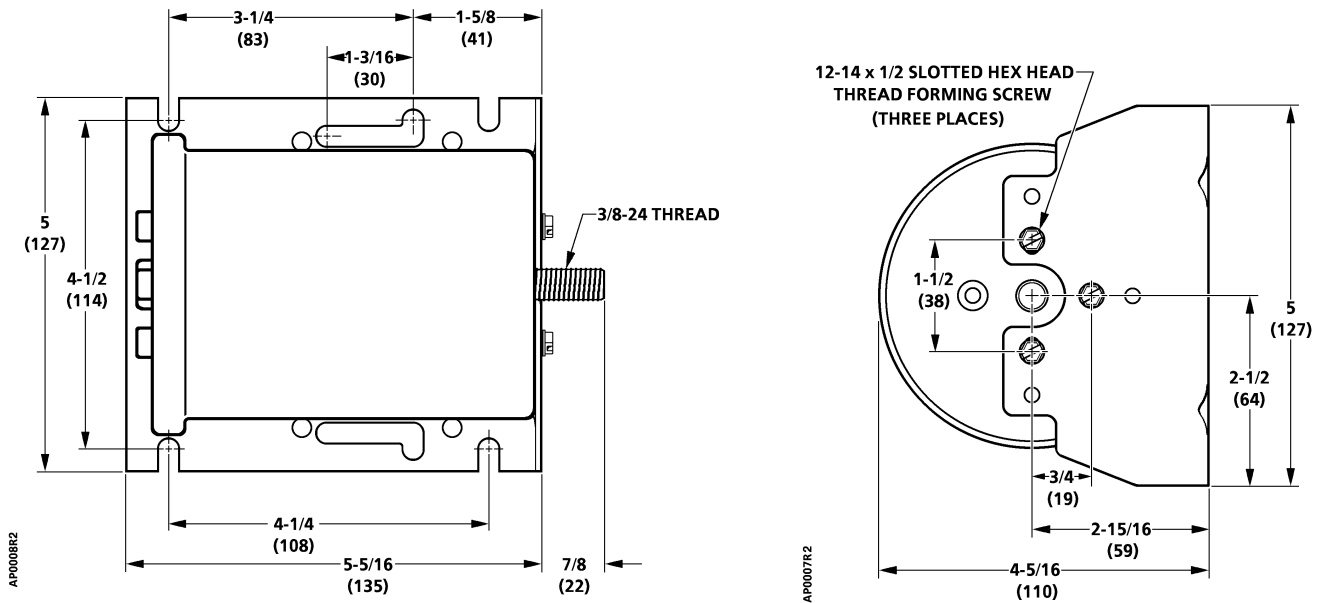

Figure 5. No. 3 Actuator with Fixed Mounting Bracket Dimensions. Dimensions are in Inches (Millimeters).

Dimensions, Continued

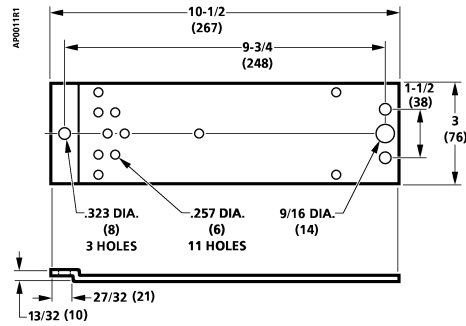

Figure 6. Extended Shaft Mounting Bracket Dimensions. Dimensions are in Inches (Millimeters).

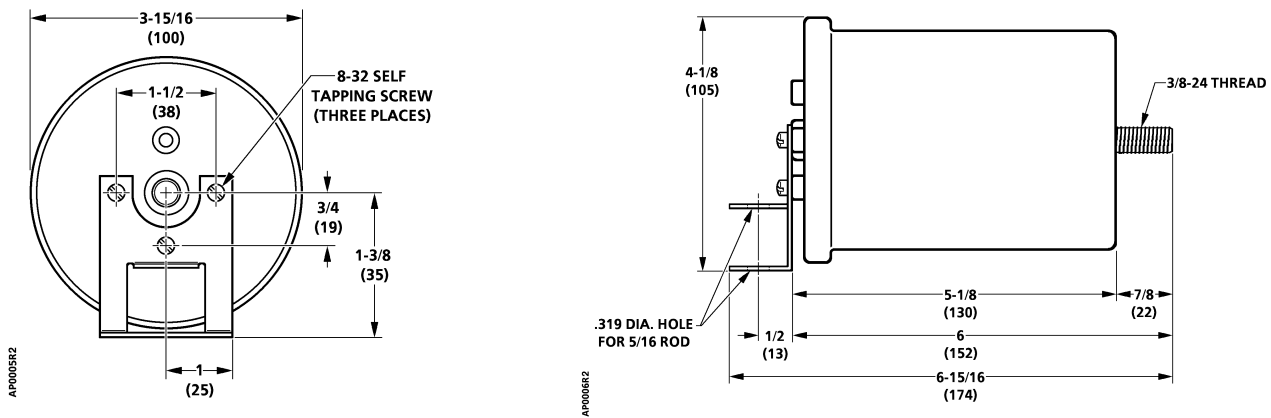

Figure 7. No. 3 Actuator with Pivot Mounting Bracket Dimensions. Dimensions are in Inches (Millimeters).

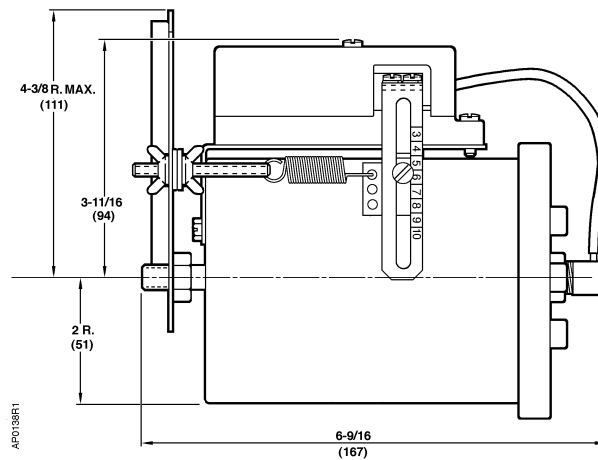

Figure 8. No. 3 Actuator with the RL 147 Positioning Relay Mounted Dimensions. Dimensions in Inches (Millimeters).

Information in this publication is based on current specifications. The company reserves the right to make changes in specifications and models as design improvements are introduced. POWERS is a registered trademark of Siemens Industry, Inc. Product or company names mentioned herein may be the trademarks of their respective owners. © 2008 Siemens Industry, Inc.

MS4120F; MS4620F; MS8120F; S2024-F; S20230-F Fast-Acting, Two-Position Actuators

PRODUCT DATA



FEATURES

- 175 lb-in. (20 Nm) minimum driving torque at 350°F (176°C).
- Reversible mounting facilitates use in either clockwise (cw) or counterclockwise (ccw) spring rotation.
- Integral spring return ensures level of return torque.
- Stainless steel internal spring.
- Fifteen-second spring return timing.
- No special cycling required during long-term holding. (See Operation section.)
- No audible noise during holding.
- Patent pending design eliminates need for limit switches to reduce power consumption.
- Models available for 24, 120, and 230 Vac applications.
- Ninety-five degree angle of rotation.
- Actuator holds rated torque at reduced power level.
- Die-cast aluminum housing.
- Housing design allows flush mounting to damper.
- Self-centering shaft adapter (SCSA), patent pending.
- Designed to operate reliably in smoke control systems requiring Underwriter's Laboratories Inc. UL555S ratings up to 350°F.

APPLICATION

The MS4120F, MS4620F, MS8120F, S2024-F, and S20230-F Fast-Acting, Two-Position Actuators are spring return direct coupled actuators (DCA) for on/off damper control. The actuator accepts an on/off signal from a single-pole, single-throw (spst) controller. Reversible mounting allows actuator to be used for either clockwise (cw) or counterclockwise (ccw) spring rotation.

Designed to operate reliably in smoke control systems requiring Underwriter's Laboratories Inc. UL555S ratings up to 350°F.

APPLICABLE LITERATURE

— Specification Data Sheet	63-2592
— Motor/Actuator Selection Guide for Damper Applications	63-8419
— Engineering Manual of Automatic Control (also called The Gray Manual)	77-1100
— Direct Coupled Actuator Quick Selection Guide	63-8553
— Damper Torque Calculator	63-8437

MS4120F, MS4620F, MS8120F

- High temperature Teflon® lead wires.
- Models available with integral high temperature (350°F) SPST position-indicating switches (7°, 85° stroke).

S2024-F, S20230-F

- Double-insulation rating.
- High-temperature, halogen-free, silicone-free leadwires.
- Models available with integral high temperature (350°F) SPDT position-indicating switches (7°, 85° stroke).



SPECIFICATIONS

Models: See Tables 1, 2, and 3.

Table 1. Models.

Model	Voltage in Vac	Internal Auxiliary Switches
MS4120F1006	120	None
MS4120F1204	120	2 SPST ^a
MS4620F1005	230	None
MS4620F1203	230	2 SPST ^a
MS8120F1002	24	None
MS8120F1200	24	2 SPST ^a
S2024-F (MS8120S1006)	24	None
S20230-F (MS4620S1009)	230	
S2024-F-SW2 (MS8120S1204)	24	2 SPDT ^a
S20230-F-SW2 (MS4620S1207)	230	

^a Internal switches are designed to pass UL555S requirements (at 350°F).

Dimensions: See Fig. 1.

Device Weight:

MS4120F, MS4620F, S20230-F: 7.5 lb (3.4 kg)
 MS8120F, S2024-F: 6.25 lb (2.8 kg)

Stroke: 95° ± 3°, mechanically limited.

Electrical Ratings:

Power Input:

MS4120F: 120 Vac ±10%, 60 Hz.
 MS4620F,S; S20230-F: 230 Vac ±10%, 50/60 Hz.
 MS8120F,S; S2024-F: 24 Vac +20%, -10%, 50/60 Hz (Class 2).

Power Consumption:

MS4120F: Driving: 0.35A, 35W. Holding: 0.15A, 10W.
 MS4620F,S; S20230-F:
 Driving: 0.20A, 35W. Holding: 0.14A, 10W.
 MS8120F,S; S2024-F: Driving: 45 VA. Holding: 10 VA.

Electrical Connections:

Lead Wires:

MS4120F, MS4620F, MS8120F: 1m Teflon wire.
 MS4620S, MS8120S, S2024-F, S20230-F: 1m halogen-free, silicone-free wire.

Two integral 3/8 in. flexible conduit connections.

Timing (At Rated Torque and Voltage):

Drive Open: 15 seconds typical.
 Spring Close: 15 seconds typical.

Auxiliary Switches:

Dry Contact
 Ratings (maximum load): 250 Vac, 5A resistive.
 Settings (fixed): 7° nominal stroke, 85° nominal stroke.

Torque Rating (at Rated Voltage):

Typical Holding (minimum at 350°F): 175 lb-in. (20 Nm).
 Spring Return (minimum at 350°F): 175 lb-in. (20 Nm).
 Stall Maximum (fully open at 75°F): 425 lb-in. (48.0 Nm).
 350°F Minimum Driving: 175 lb-in. (20 Nm).

Design Life (at Rated Voltage): 30,000 full stroke cycles.

Minimum Damper Shaft Length:

1 in. (25 mm); 3-1/4 (83 mm) recommended.

Cycling Requirements:

Prolonged holding-period (1 year) testing of these actuators has been performed with no spring return failures. The actuator and the internal spring are designed to require no special cycling during long-term holding.

Honeywell recommends following all local, state and national codes for periodic testing of the entire smoke control system. Refer to National Fire Protection Association (NFPA) National Fire Codes®: NFPA90A, NFPA92A and NFPA92B for your application.

NFPA recommends periodic examination of each fire/smoke damper (semi-annually or annually) to ensure proper performance.

Mounting: Self-centering shaft adapter.

Round Damper Shafts: 0.5 to 1.06 in.

Square Damper Shafts: 1/2 to 3/4 in.

Actuator can be mounted with shaft in any position.

IMPORTANT

- Honeywell does not recommend using linkages with these actuators because side-loading of the output hub reduces actuator life.
- 3/4 in. or greater shaft diameter recommended.

Noise Rating at 1m (Maximum):

Driving or Spring Return: 70 dBA.

Holding: 20 dBA (no audible noise).

Vibration:

Not suitable for high vibration applications (Example installation environment: Truck Trailers or Railroad Cars)

Acceptable Vibration Levels 0.6g at 30 to 300 Hz.

Temperature Ratings:

Ambient: -40°F to 130°F (-40°C to 55°C).

Shipping and Storage: -40°F to 140°F (-40°C to 60°C).

IMPORTANT

The actuator is designed to meet UL555S standards at 350°F (176°C). The actuator must be tested with the damper to achieve this rating.

NOTE: The actuator is designed to operate for 30 minutes during a one-time excursion to 350°F (176°C).

Humidity Ratings: 5% to 95% RH noncondensing.

Environmental Protection Ratings:

NEMA2 and IP54 when mounted on a horizontal shaft and the base of the actuator below the shaft.

Accessories:

205649 Mounting Bracket (not supplied with actuator).

Approvals: See Table 4.

Controller Type:

MS4120F: Line voltage (120 Vac), 2-position, spst (Series 40).

MS4620F,S; S20230-F: Line voltage (230 Vac), 2-position, spst (Series 40).

MS8120F,S; S2024-F: Low voltage (24 Vac), 2-position, spst (Series 80).

Table 2. Actuator Selection (MS Series)

M	Electrical Motor
S	Fail Safe Function (Spring Return)
41	120 Vac 2-position Control; Reversible Mount Spring Return
46	230 Vac 2-position Control; Reversible Mount Spring Return
81	24 Vac 2-position Control; Reversible Mount Spring Return
20	175 lb-in. (20 Nm)
F	Fire and Smoke (US)
1	No Feedback
0	No Auxiliary Switches
2	Two Auxiliary Switches
XX	System Controlled Numbers

M S 41 20 F 1 2 XX

Table 3. Actuator Selection (S20 Series).

S	Fail Safe Function (Spring Return)
20	20 Nm (175 lb-in.)
24	24 Vac 2-position Control; Reversible Mount Spring Return
230	230 Vac 2-position Control; Reversible Mount Spring Return
F	Fire and Smoke Actuator
	No Auxiliary Switches
-SW2	Two Auxiliary Switches

S 20 24 - F -SW2

Table 4. Approvals.

	MS4120F	MS4620F, MS8120F	S20230-F	S2024F
UL/cUL	X	X		
UL873 Plenum Rating, File No. E4436; Guide No. XAPX. ^a	X	X		
CE		X	X	
C-TICK		X	X	X

^a Plenum applications require that conductors be enclosed in conduit (see Wiring section for conduit details).

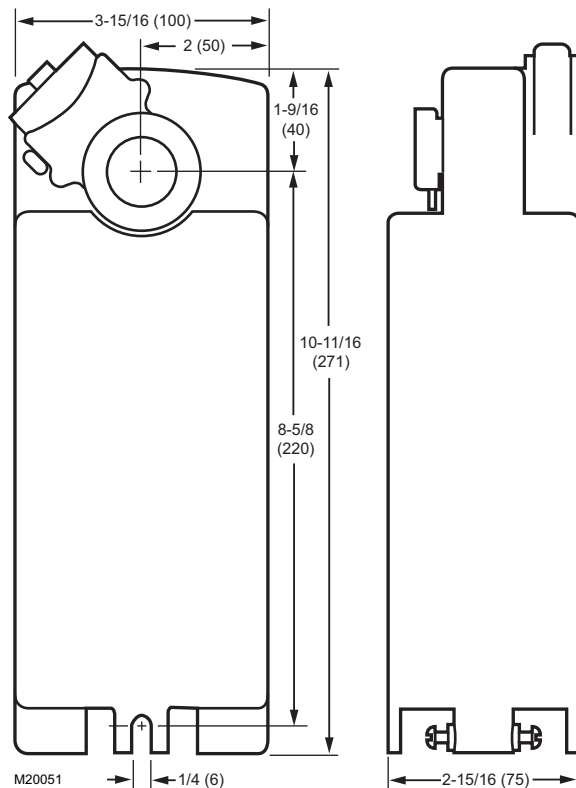

Fig. 1. Dimensional drawing of actuator in in. (mm).

INSTALLATION

When Installing this Product...

1. Read these instructions carefully. Failure to follow them could damage the product or cause a hazardous condition.
2. Check the ratings given in the instructions and on the product to make sure the product is suitable for your application.
3. Installer must be a trained, experienced service technician.
4. After installation is complete, check out product operation as provided in these instructions.

WARNING

Electrical Power Hazard.
Line voltage can cause death or serious injury and short equipment circuitry.
Disconnect power supply before installation.



CAUTION

Electrical Shock or Equipment Damage Hazard.
Low voltage can shock individuals or short equipment circuitry.
Disconnect power supply before installation.

IMPORTANT

All wiring must agree with applicable codes, ordinances and regulations.

Location

The actuators are designed to open a damper by driving the damper shaft in either a clockwise  or counterclockwise  direction. The actuator housing has two slots on the bottom, either of which, with a 205649 Mounting Bracket, secures it flush to a damper box (see Fig. 2).

NOTE: When mounted correctly, these slots allow the actuator to *float* without rotating relative to the damper shaft.

CAUTION

Equipment Damage Hazard.
Tightly securing actuator to damper housing can damage actuator.
Mount actuator to allow it to float along its vertical axis.

Preparation

Before mounting the actuator onto the damper shaft, determine the:

- Damper/valve opening direction for correct spring return rotation. The actuator can be mounted to provide clockwise or counterclockwise spring return.
- Damper shaft size (see Specifications section).

Determine Appropriate Mounting Orientation

See Fig. 2 for mounting orientation.

NOTES:

- Actuators are shipped in the fully closed position.
- An arrow molded into the hub points to tick marks on the label to indicate the hub rotary position.
- See Fig. 3 for proper mounting to a square damper shaft.

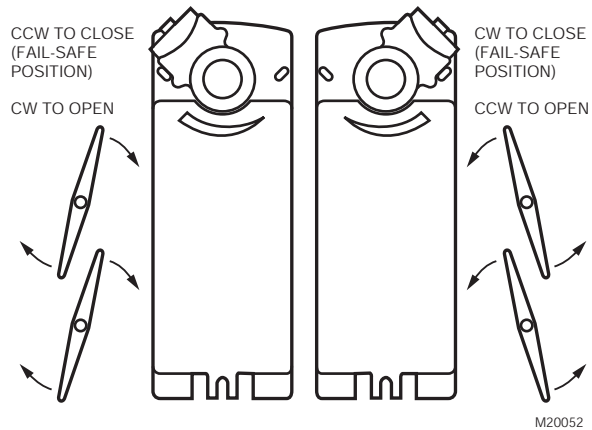

Fig. 2. Spring Return DCA mounting orientation.

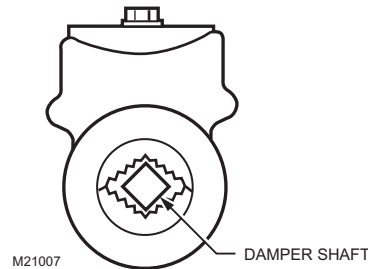

Fig. 3. Proper mounting to square damper shaft.

Measure Damper/Valve Shaft Length

If the shaft is less than three inches in length, the shaft coupling must be located between the damper/valve and actuator housing. If the shaft length is more than three inches, the shaft coupling may be located on either side of the actuator housing.

If the coupling must be moved from one side of the actuator to the reverse, follow these instructions (see Fig. 4):

1. Remove the retainer clip from the shaft coupling and set it aside for later use.
2. Remove shaft coupling from one side of the actuator.
3. Replace the shaft coupling on the opposite side of the actuator aligning it based on the stroke labelling.
4. Replace the retainer clip on the shaft coupling using the groove of the coupling.

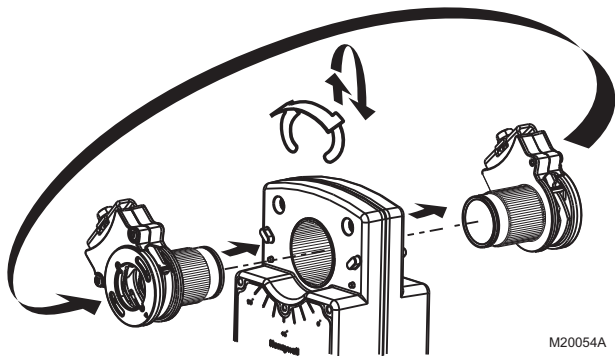

M20054A

Fig. 4. Mounting shaft coupling to actuator opposite side.

Mounting



CAUTION

Device Malfunction Hazard.
Improper shaft coupling tightening causes device malfunction.
 Tighten shaft coupling with proper torque to prevent damper shaft slippage.



CAUTION

Actuator Damage Hazard.
Using actuator as shaft bearing causes device damage.
 Use actuator only to supply rotational torque. Avoid any side loads to actuator output coupling bearings.

To mount actuator, proceed as follows:

1. Place actuator over damper shaft; and hold mounting bracket in place. See Fig. 5.
2. Mark screw holes on damper housing.
3. Remove actuator and mounting bracket.
4. Drill or center-punch holes for mounting screws (or use no.10 self-tapping sheet metal screws).

NOTE: If necessary, use a field-fabricated steel base plate secured with sheet metal screws.

5. Turn damper blades to desired normal (closed) position.
6. Place actuator and mounting bracket back into position and secure bracket to damper box with sheet metal screws.
7. Using 10 mm wrench, tighten shaft coupling securely onto damper shaft using minimum 120 lb-in., maximum 180 lb-in. torque.

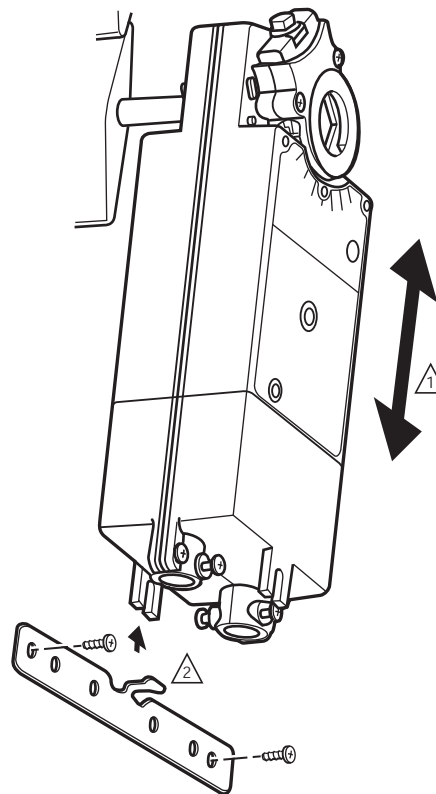

1. ENSURE THAT MOUNTING ASSEMBLY PREVENTS ACTUATOR ROTATION AND ALLOWS ACTUATOR TO FLOAT ALONG INDICATED AXIS. WHEN TOO TIGHT, THE RESULTING BINDING CAN DAMAGE THE ACTUATOR OR REDUCE TORQUE OUTPUT.
2. ACCESSORY MOUNTING BRACKET IS NOT SUPPLIED WITH THE ACTUATOR.

M20055

Fig. 5. Mounting actuator to damper housing.

Manual Positioning

The actuator can be operated with no power present. Use this feature during installation or to move and lock the damper or valve shaft position when there is no power.

To operate the manual positioning:

1. If the power is on, turn it off.
2. Insert supplied hex wrench (key) as shown in Fig. 6.
3. Rotate key in the direction indicated on the cover.
4. Once the desired position is reached, hold the key to prevent the spring return from moving the actuator.

NOTE: No detente for fire and smoke actuators. If key is released, actuator will return to spring closed position.

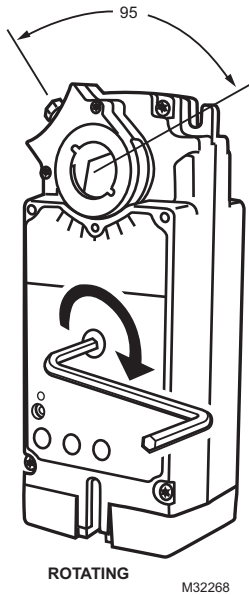

Fig. 6. Manual positioning.

WIRING

See Fig. 7 through 11 for typical wiring diagrams.

⚠ WARNING

Electrical Power Hazard.
Line voltage can cause death or serious injury and short equipment circuitry.
Disconnect power supply before installation.

⚠ CAUTION

Electrical Shock or Equipment Damage Hazard.
Disconnect all power supplies before installation.
Motors with auxiliary switches can have more than one disconnect.

IMPORTANT

1. All wiring must comply with local electrical codes, ordinances and regulations.
2. Voltage and frequency of transformer used with MS8120F,S and S2024-F must correspond with the characteristics of power supply and actuator.

NOTE: The conduit fittings are designed for use with 3/8 in. reduced-wall steel or aluminum flexible conduit.

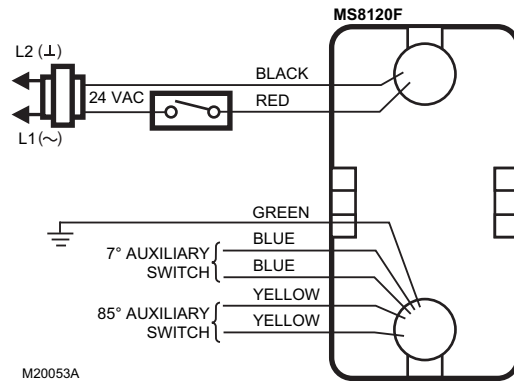

Fig. 7. Typical 24 Vac wiring (MS Series).

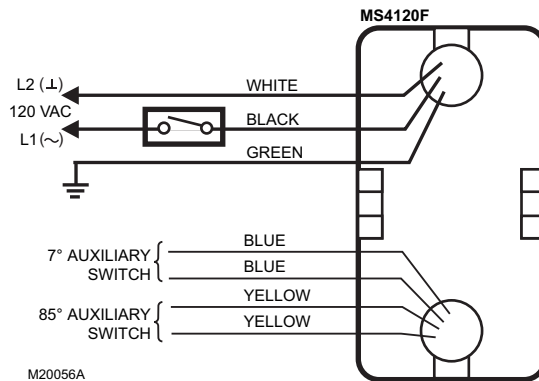

Fig. 8. Typical 120 Vac wiring (MS Series).

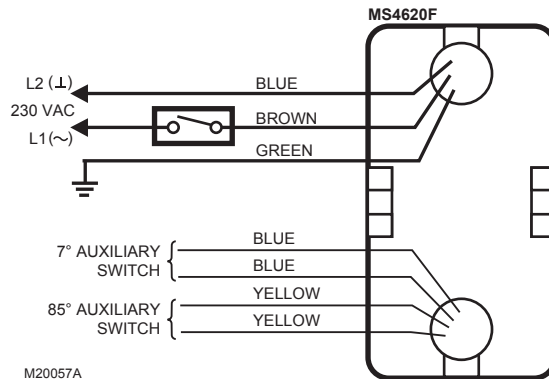

Fig. 9. Typical 230 Vac wiring (MS Series).

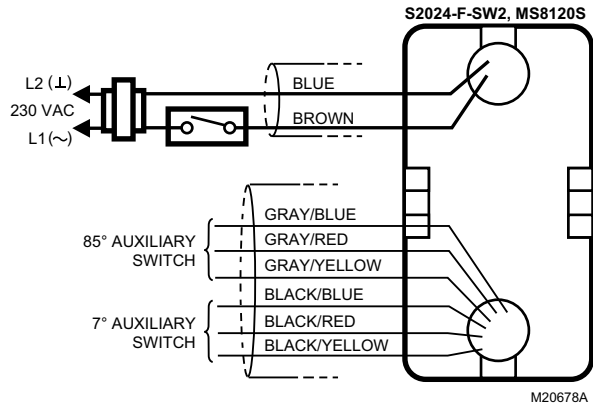

Fig. 10. Typical 24 Vac wiring (S20 Series).

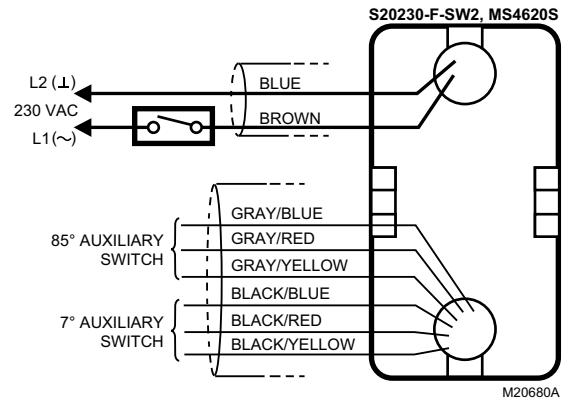

Fig. 11. Typical 230 Vac wiring (S20 Series).

OPERATION

The actuators are designed for use in Smoke Control Systems. If power fails, the actuator spring returns to the 0° position. The actuator mounts flush with the damper box. The actuator drives from 0° to 95° and spring returns back to 0°.

The actuators are operated by an spst two-position controller. When using an spst two-position controller, the actuator drives to the damper fully open position when controller contact makes and spring returns to the damper fully closed position when controller contact breaks. The actuator drops to holding power level on detection of stall, independent of hub position.

Cycling

The actuator and the internal spring are designed so that no special cycling during long-term holding is required. Honeywell recommends following all local, state, and national codes for periodic testing of the entire smoke control system. Refer to National Fire Protection Association (NFPA) National Fire Codes®: NFPA90A, NFPA92A, and NFPA92B for your application.

Auxiliary Switches

Some models include auxiliary switches (see Table 1).

SPST Switches (Table 5)

See Fig. 7 through 9 for SPST auxiliary switch wiring.

Table 5. SPST Auxiliary Switch Operation.

Switch	Wire Color	Makes	Breaks
		(degrees from fully closed position)	
7°	blue	less than 7	greater than 7
85°	yellow	greater than 85	less than 85

NOTE: Both sets of contacts are open when the actuator is between 7° and 85°.

SPDT Switches (Fig. 12)

See Fig. 10 through 12 for SPDT auxiliary switch wiring.

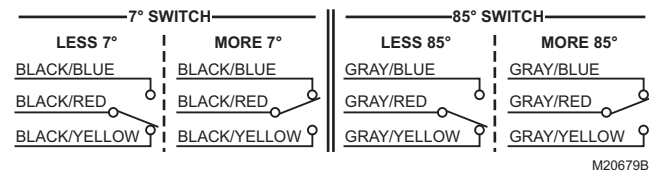

Fig. 12. SPDT auxiliary switch operation.

CHECKOUT

MS4120F (120 Vac model)

1. Check damper position.
2. Connect 120 Vac to the black and white leadwires to drive the damper to the open position. The actuator should drive the damper.
3. If the actuator does not run, remove power for at least two seconds.
4. If the actuator spring returns, allow it to close entirely, then return to step 2.
5. If the actuator does not spring return, verify that the actuator is properly installed. See Installation section.
6. If the actuator is correctly installed but neither runs nor spring returns, replace the actuator.

MS4620F; S20230-F (230 Vac models)

1. Check damper position.
2. Connect 230 Vac to the blue and brown leadwires to drive the damper to the open position. The actuator should drive the damper.
3. If the actuator does not run, remove power for at least two seconds.
4. If the actuator spring returns, allow it to close entirely, then return to step 2.
5. If the actuator does not spring return, verify that the actuator is properly installed. See Installation section.
6. If the actuator is correctly installed but neither runs nor spring returns, replace the actuator.

MS8120F; S2024-F (24 Vac models)

1. Check damper position.
2. Connect 24 Vac to the red and black leadwires to drive the damper to the open position. The actuator should drive the damper.
3. If the actuator does not run, remove power for at least two seconds.
4. If the actuator spring returns, allow it to close entirely, then return to step 2.
5. If the actuator does not spring return, verify that the actuator is properly installed. See Installation section.
6. If the actuator is correctly installed but neither runs nor spring returns, replace the actuator.

D Montageanweisung

F Instructions d'Installation

I Istruzioni per l'Installazione

NL Installatievoorschrift

DK Installasjonsinstruks

N Installationsinstruktioner

SF Asennusohje

S Installations Instruktioner

E Instrucciones de montaje

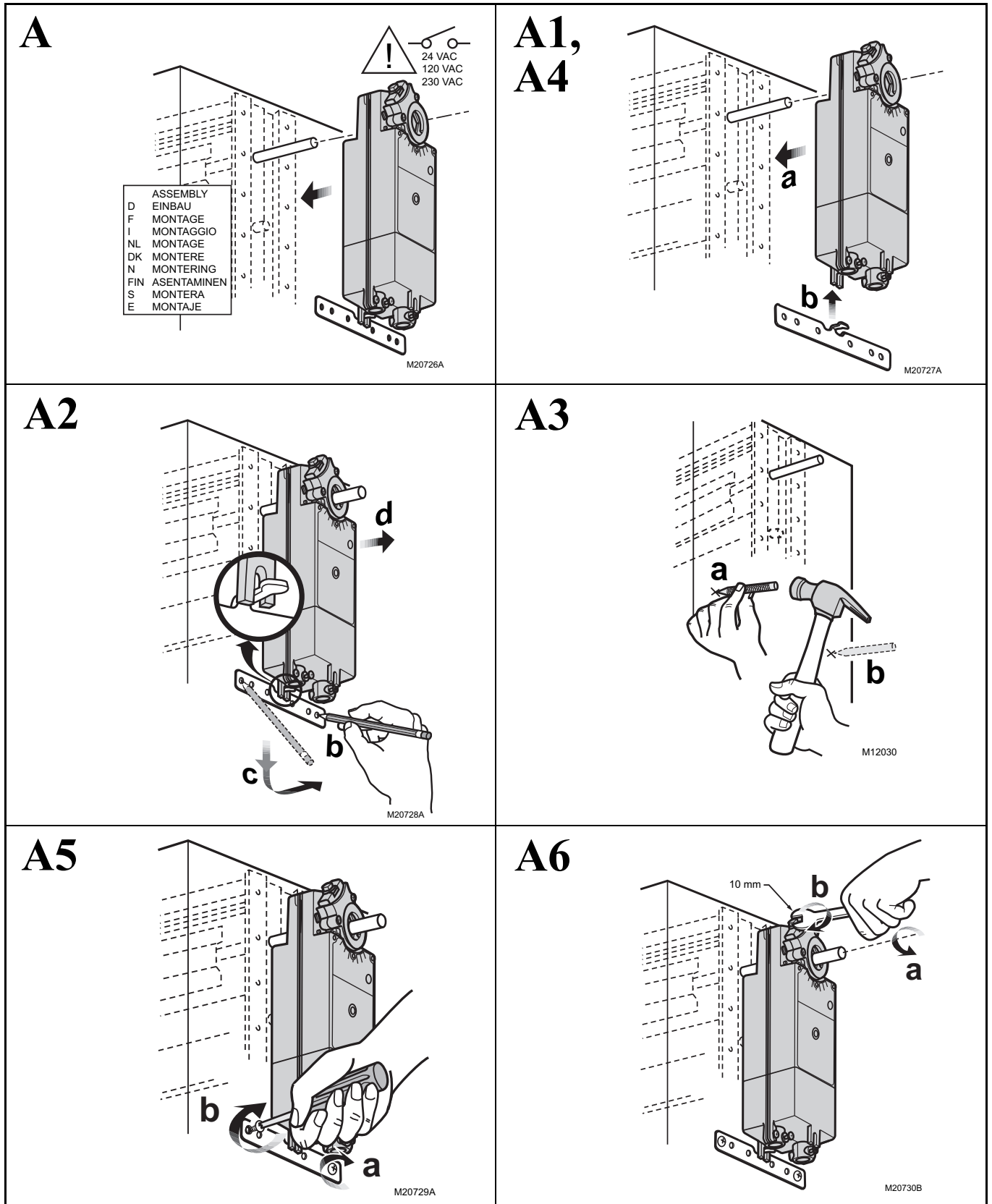

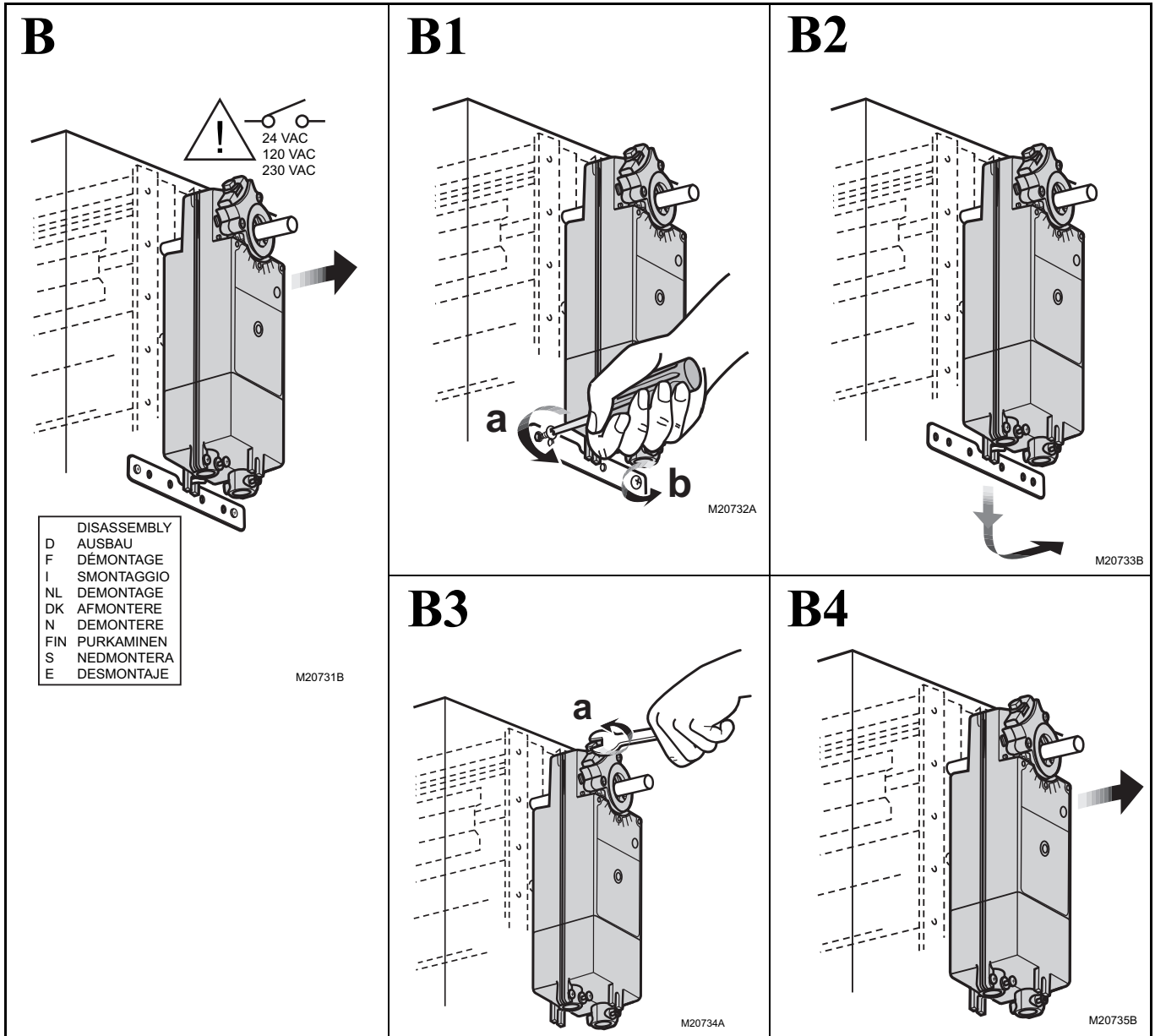

MS4120F; MS4620F; MS8120F; S2024-F; S20230-F FAST-ACTING, TWO-POSITION ACTUATORS

Teflon® is a registered trademark of the E.I. du Pont de Nemours and Company.

National Fire Codes® is a registered trademark of the National Fire Protection Association (NFPA).

Automation and Control Solutions

Honeywell International Inc.
1985 Douglas Drive North
Golden Valley, MN 55422
customer.honeywell.com

© U.S. Registered Trademark
© 2012 Honeywell International Inc.
63-2584—10 M.S. Rev. 03-12
Printed in United States

Honeywell

PERFORMANCE DATA:

MODELS: 1201-MDG AND 1201-MDS

PRESSURE DROP:

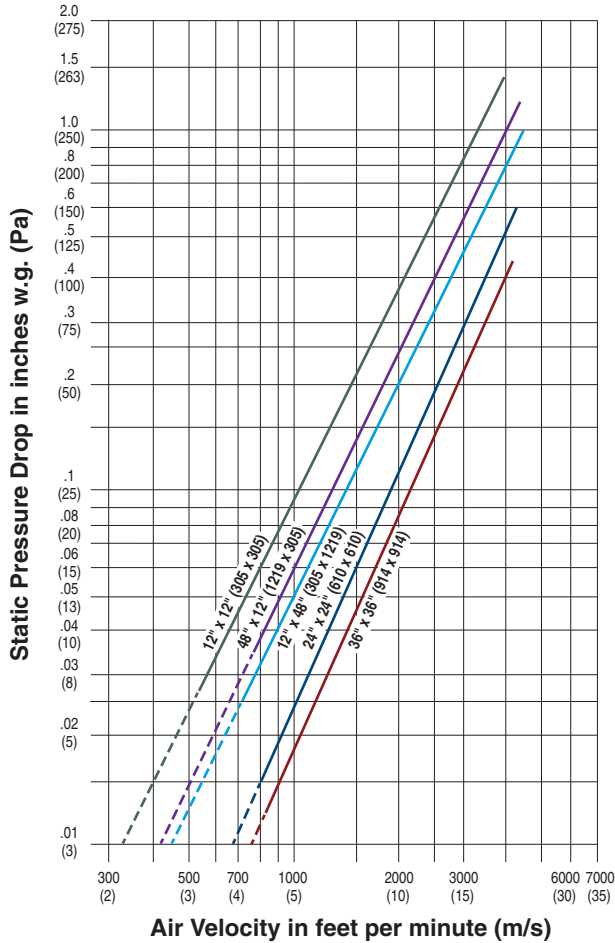

Pressure drop tested per AMCA Standard 500-D, Figure 5.3.
Data corrected to standard air density of 0.075 lbs/ft.³.

HOW TO SPECIFY

SUGGESTED SPECIFICATION:

Provide and install, as shown on plans and/or schedules, Multi-Blade Marine Fire Dampers as manufactured by Nailor Industries, Inc. which meet or exceed the following criteria: Dampers shall be tested and rated in accordance with the latest edition of International Maritime Organization Fire Test Procedures Code Coast Guard Approval Type A-60 and also bear the European Wheel Mark in accordance with Marine Equipment Directive 96/98/EC.

Frame shall be constructed of 16 ga. (1.6) (**specifier to select**) galvanized steel (**Model 1201-MDG**) or Type 304 Stainless Steel (**Model 1201-MDS**) or Type 316 Stainless Steel (**Model 1201-MDS**) hat channel with mitered corners reinforced with die-formed corner gussets for strength. Blades shall be 14 ga. (2.0) equivalent (**specifier to select**) galvanized steel (**Model 1201-MDG**) or Type 304 Stainless Steel (**Model 1201-MDS**) or Type 316 Stainless Steel (**Model 1201-MDS**) formed double skin, airfoil design, on 5 1/2" (140) centers. Dampers shall be of opposed blade configuration with an interlocking blade design. Blade seals are not acceptable. Damper shall be equipped with stainless steel jamb seals for low leakage performance. Bearings shall be (**specifier to select**) self-lubricating oilite bronze type (**Model 1201-MDG**) or Stainless Steel (**Model 1201-MDS**). Blade linkage shall be zero-maintenance, concealed in frame, out of airstream.

The heat responsive device shall have a temperature rating of (**specifier select temperature**) 165°F (74°C) or 212°F (100°C). Appropriate externally mounted electric actuators shall be installed by the damper manufacturer in the factory. Actuators shall incorporate an OEM internal spring return mechanism, external after-market spring mechanisms are not acceptable. Damper and actuator assembly shall be factory cycled a minimum of 3 times to ensure correct operation.

Standard of acceptance shall be Nailor Model (**specifier to select**) 1201-MDG (Galvanized Steel) or 1201-MDS (Stainless Steel).

QUALIFICATIONS:

International Maritime Organization Fire Test Procedures Code
 USCG Type Approval A-60. Approval Number 164.139/8/0.

European Wheel Mark  1408/05.

Southwest Research Institute Test report No. 01.10933.01.701.

MINIMUM SIZE: Vertical or Horizontal mount: 8" x 8" (200 x 200).
MAXIMUM SIZE: Single Section
 Vertical or Horizontal mount: 36" x 36" (915 x 915).
 Multiple Section Assembly
 Vertical or Horizontal mount: 72" x 36" (1830 x 915).

Nailor's Model 1201-MDG (galvanized), and 1201-MDS (stainless steel) marine fire dampers have been tested for 60 minutes, in both a Class A bulkhead and Class A deck, in accordance with the International Maritime Organization's Fire Test Procedure (FTP). Dampers are required by FTP to be welded or bolted to the ductwork (coaming) as described below, and that the ductwork (coaming) be insulated as described below. See Figures 1 and 2 below.

The ductwork (coaming) must be insulated on the damper side a minimum of 6" (152 mm) and also on the non-damper side a minimum of 18" (457 mm), using any A60 rated U.S. Coast Guard approved insulation. Install the insulation with 0.106" (2.7 mm) steel pins and 1.12" x 1.24" x 0.4" (28 mm x 31 mm x 10 mm) steel clips.

Either 3/8" (9.5 mm) by 1" (25 mm) long bolts, or welding may be used to attach damper to ductwork (coaming). Whether bolts or welding are used, the fasteners should be placed on 6" (152 mm) centers, and no more than 2" (51 mm) from corners.

Available pneumatic actuators: 331-2961 and 331-4826.

Available electric actuators: MS4120F, MS4620F, MS8120F, MS4x09F, or MS8x09F.

See installation instructions for each actuator.

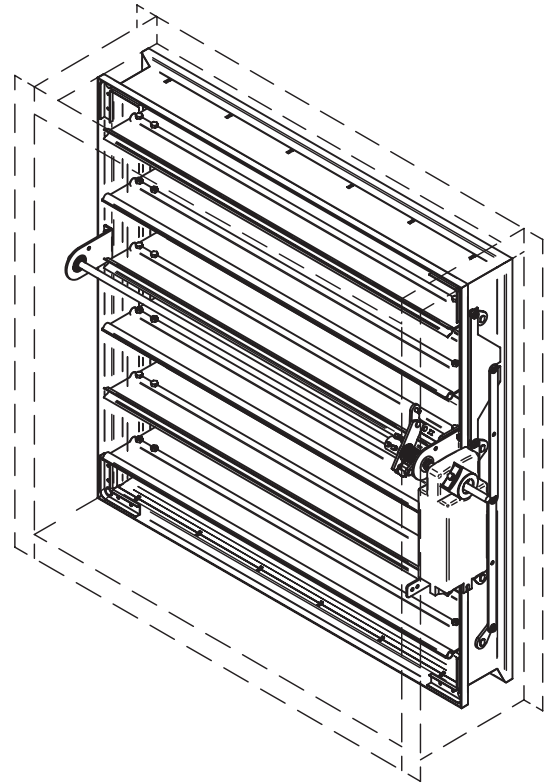

Shown with an electric actuator and RH mounting. Pneumatic actuators, hand locking quadrant and LH mounting are available.

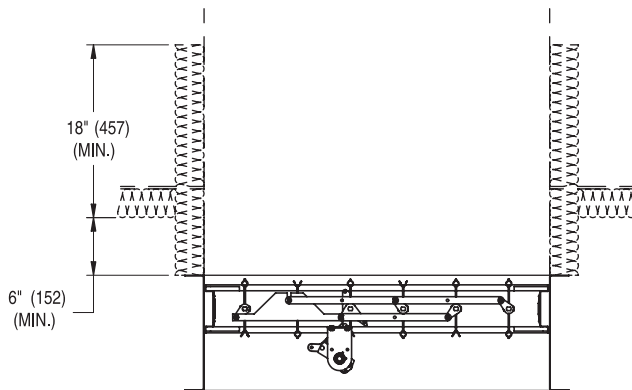

Fig. 1: Horizontal damper mount

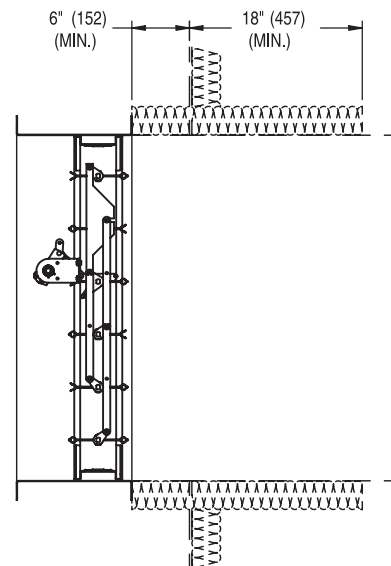

Fig. 2: Vertical damper mount



Houston, Texas
Tel: 281-590-1172
Fax: 281-590-3086

Las Vegas, Nevada
Tel: 702-648-5400
Fax: 702-638-0400

Toronto, Canada
Tel: 416-744-3300
Fax: 416-744-3360

Calgary, Canada
Tel: 403-279-8619
Fax: 403-279-5035



U. S. Department of Homeland Security United States Coast Guard Certificate of Approval

Coast Guard Approval Number: 164.139/8/0

Expires: 17 July 2024

FIRE DAMPERS

NAILOR INDUSTRIES INC.
4714 Winfield Road
Houston TX 77039

A-Class Fire Dampers, Model 1201 MDG (Galvanized) and Model 1201 MDS (Stainless), tested and approved in accordance with the IMO FTP Code Annex 1, Part 3.

Dampers approved for use in ducts penetrating Class A-0/A-15/A-30/A-60 bulkheads or decks. Damper and ventilation penetration must be insulated to the same criteria as the division penetrated. Maximum size is 1830 mm X 915 mm, double ganged. Minimum size is 200 mm X 200 mm. Approved actuators for direct mounting are fusible link, Honeywell Series MSXXXXF1X10 electric, and Siemens Power Controls No. 3 and No. 4 pneumatic. May use any electric, pneumatic or manual actuator mounted with 2-inch stand-off bracket. May have optional position indicator switch pack. Sleeve length shall be between 8 and 24 inches (203 and 610 mm). Sleeves are to be at least 16 USSG thick. Flange width may be between 1 and 3 inches (25 and 76 mm), but the mounting bolts shall be no more than 2 inches (51 mm) away from the damper sleeve. Fusible link may be either 165 F or 212 F.

Identifying Data: Part 3 - SwRI Test report No. 01.10933.01.701 dated February 2005; and USCG letter dated June 23, 2014.

Approval valid only for products manufactured at factory in Houston, TX, USA.
Follow-up Program: SwRI.

Extends certificate dated July 17, 2014.



1408/YY

The manufacturer is allowed to affix the Mark of Conformity according to Article 10 in the Council Directive 2014/90/EC on Marine Equipment and issue a Declaration of Conformity as allowed by the "Agreement between the European Community and the United States of America on Mutual Recognition of Certificates of Conformity for Marine Equipment" signed February 2019 and by the "Agreement between the European Free Trade Association countries which are part of the European Economic Area and the United States of America on Mutual Recognition of Certificates of Conformity for Marine Equipment" signed February 2019. Item complies with requirements of Annex II, Item No. MED/3.22 of the directive.

*** End ***

THIS IS TO CERTIFY THAT the above named manufacturer has submitted to the undersigned satisfactory evidence that the item specified herein complies with the applicable laws and regulations as outlined on the reverse side of this Certificate, and approval is hereby given. This approval shall be in effect until the expiration date hereon unless sooner canceled or suspended by proper authority.

GIVEN UNDER MY HAND THIS 17th DAY OF
JULY 2019, AT WASHINGTON D.C.

B. A. BALDWIN
Chief, Lifesaving and Fire Safety Division
BY DIRECTION OF THE COMMANDANT



TERMS: The approval of the item described on the face of the Certificate has been based upon the submittal of satisfactory evidence that the item complies with the applicable provisions of the navigation and shipping laws and the applicable regulations in Title 33 and/or Title 46 of the Code of Federal Regulations. The approval is subject to any conditions noted on this Certificate and in the applicable laws and regulations governing the use of the item on vessels subject to Coast Guard inspection or on other vessels and boats.

Consideration will be given to an extension of this approval provided application is made 3 months prior to the expiration date of this Certificate.

The approval holder is responsible for making sure that the required inspections or tests of materials or devices covered by this approval are carried out during production as prescribed in the applicable regulations.

The approval of the item covered by this certificate is valid only so long as the item is manufactured in conformance with the details of the approved drawings, specifications, or other data referred to. No modification in the approved design, construction, or materials is to be adopted until the modification has been presented for consideration by the Commandant and confirmation received that the proposed alteration is acceptable.

NOTICE: Where a manufacturer of safety-at-sea equipment is offering for sale to the maritime industry, directly or indirectly, equipment represented to be approved, which fails to conform with either the design details or material specifications, or both, as approved by the Coast Guard, immediate action may be taken to invoke the various penalties and sanctions provided by law including prosecution under 46 U.S.C. 3318, which provides:

"A person that knowingly manufactures, sells, offers for sale, or possesses with intent to sell, any equipment subject to this part (*Part B. of Subtitle II of Title 46 U.S.C.*) and the equipment is so defective as to be insufficient to accomplish the purpose for which it is intended, shall be fined not more than \$10,000, imprisoned for not more than 5 years or both."