

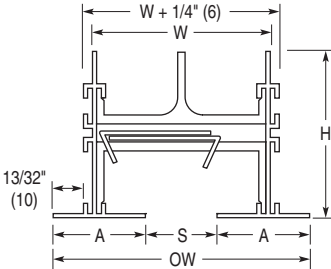

**FLOWLINE™ LINEAR SLOT DIFFUSERS**  
**ARCHITECTURAL • ALUMINUM**  
**HORIZONTAL HIGH THROW PATTERN CONTROLLERS**  
**MODEL SERIES: FLH TYPES AA & AAC**

**One Slot**

- Type AA Exposed Flange Frame**
- Drywall (ceiling, wall), T-Bar



**Two Slot**

- Type AA Exposed Flange Frame**
- Drywall (ceiling, wall), T-Bar

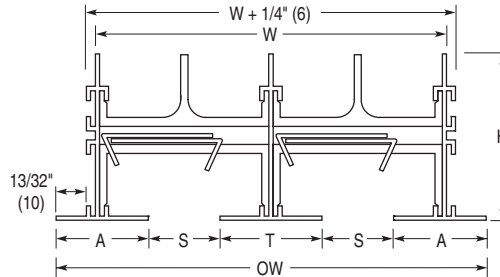

**Dimensional Data - Imperial (Metric) Units**

Model	S Slot Width	1 Slot		2 Slot		A Border Width	H Height	T 2 Slot
		W	OW	W	OW			
FLH10	1 (25)	2 1/2 (64)	3 9/16 (90)	4 15/16 (125)	6 (152)	1 9/32 (33)	2 3/8 (60)	1 7/16 (37)
FLH15	1 1/2 (38)	3 1/2 (89)	4 9/16 (116)	6 15/16 (176)	8 (203)	1 17/32 (39)	2 5/8 (67)	1 15/16 (49)
FLH20	2 (51)	4 1/2 (114)	5 9/16 (141)	8 15/16 (227)	10 (254)	1 25/32 (45)	2 7/8 (73)	2 7/16 (62)
FLH25	2 1/2 (64)	5 1/2 (140)	6 9/16 (167)	10 15/16 (278)	12 (305)	2 1/32 (52)	3 1/8 (79)	2 15/16 (75)
FLH30	3 (76)	6 1/2 (165)	7 9/16 (192)	12 15/16 (329)	14 (356)	2 9/32 (58)	3 3/8 (86)	3 7/16 (87)

- Type AAC Exposed Flange Frame**
- Drywall (ceiling)

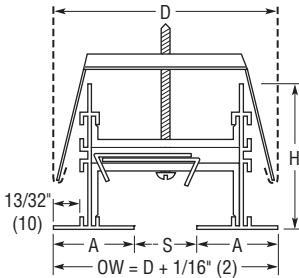

- Type AAC Exposed Flange Frame**
- Drywall (ceiling)

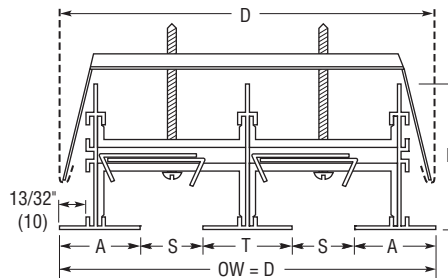

**Dimensional Data - Imperial (Metric) Units**

Model	S Slot Width	D Duct Width		Ceiling Opening Width		A Border Width	H Height	T 2 Slot
		1 Slot	2 Slot	1 Slot	2 Slot			
FLH10	1 (25)	3 1/2 (89)	6 (152)	3 (76)	5 1/2 (140)	1 9/32 (33)	2 3/8 (60)	1 7/16 (37)
FLH15	1 1/2 (38)	4 1/2 (114)	8 (203)	4 (102)	7 1/2 (191)	1 17/32 (39)	2 5/8 (67)	1 15/16 (49)
FLH20	2 (51)	5 1/2 (140)	10 (254)	5 (127)	9 1/2 (241)	1 25/32 (45)	2 7/8 (73)	2 7/16 (62)
FLH25	2 1/2 (64)	6 1/2 (165)	12 (305)	6 (152)	11 1/2 (292)	2 1/32 (52)	3 1/8 (79)	2 15/16 (75)
FLH30	3 (76)	7 1/2 (191)	14 (356)	7 (178)	13 1/2 (343)	2 9/32 (58)	3 3/8 (86)	3 7/16 (87)

**Notes:**

- Material: Heavy duty extruded aluminum frame and spacers. Corrosion resistant steel pattern controllers.
- Maximum section length is 72" (1823) by default. 96" (2438) and 120" (3048) are available as options. Lengths longer than the maximum section length are furnished in multiple sections with alignment strips, the number and size determined by the factory.
- Adjustable pattern controllers are on 24" (610) centers.
- AW Appliance White finish with black pattern controllers and interior surfaces is standard on frame/borders AA and AAC. Optional finishes are available.
- Frame/Border Type AA is supplied w/integral hanger brackets on 24" (610) centers. Frame/Border Type AAC is supplied with concealed mounting brackets and levelling screws on 24" (610) centers. See separate submittal for optional mounting hardware and accessories.

**Option:**

- SP Special Finish \_\_\_\_\_.

**Overall Length & End Cap Position**

	E	L
<input type="checkbox"/> MM	D - 1/4 (6)	D + 9/16 (14)
<input type="checkbox"/> MO	D - 1/8 (3)	D + 9/32 (7)
<input type="checkbox"/> MC	D - 1/16 (2)	D + 11/32 (9)
<input type="checkbox"/> OO	D	D
<input type="checkbox"/> OC	D - 1/16 (2)	D - 1/16 (2)
<input type="checkbox"/> CC	D - 1/8 (3)	D - 1/8 (3)
<input type="checkbox"/> FF	D - 1/4 (6)	D + 1 5/8 (41)
<input type="checkbox"/> FO	D - 1/8 (3)	D + 13/16 (21)
<input type="checkbox"/> FC	D - 1/16 (2)	D + 7/8 (22)

**End Condition**

- M Mitered End Border**

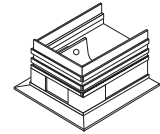
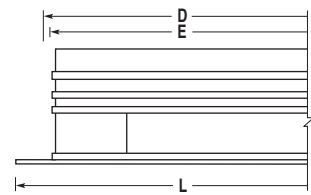

- F Flanged End Cap**  
Type AA Border Only

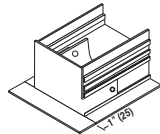
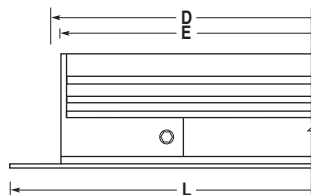

- O Open End**

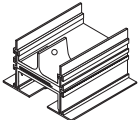
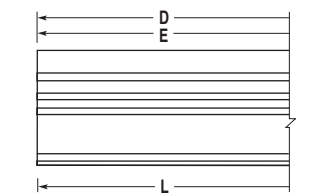

- C Flat End Cap**

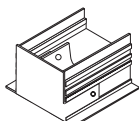
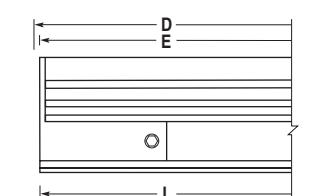

Dimensions are in inches (mm).

**SCHEDULE TYPE**

**PROJECT**

**ENGINEER**

**CONTRACTOR**

**DATE**

**B SERIES**

**SUPERSEDES**

**DRAWING NO.**

2 - 11 - 22

FL

4 - 12 - 16R

FLH-1

**AVAILABLE SHAPES FOR ARMSTRONG® DESIGNFLEX™ CEILINGS**

(All views are face views.)

**Triangles**

NOMINAL 60° TRIANGLE

- 24" BEAM SPACING x 24" BASE
- 48" BEAM SPACING x 48" BASE

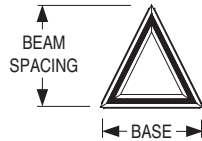

NOMINAL 45° TRIANGLE

- 24" BEAM SPACING x 48" BASE

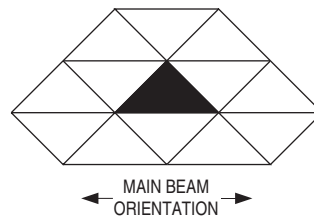

NOMINAL 75° TRIANGLE

- 48" BEAM SPACING x 24" BASE

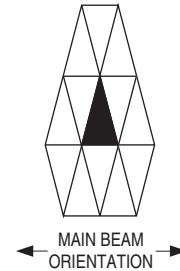
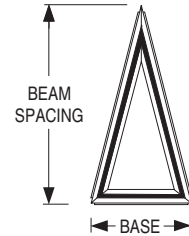

90° TRIANGLE, LEFT

- 24" BEAM SPACING x 48" BASE

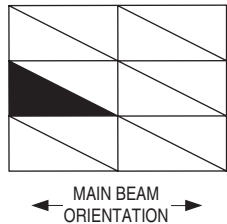
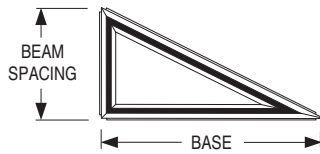

90° TRIANGLE, RIGHT

- 24" BEAM SPACING x 48" BASE

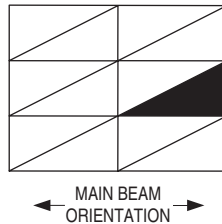
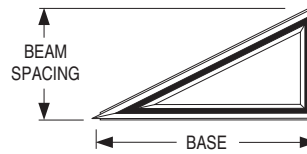

90° TRIANGLE, SYMMETRICAL

- 24" BEAM SPACING x 24" BASE
- 48" BEAM SPACING x 48" BASE

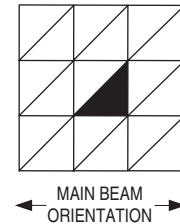
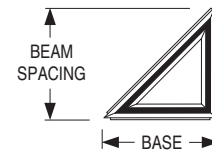

**Parallelograms**

NOMINAL 60° PARALLELOGRAM, LEFT

- 24" BEAM SPACING x 24" BASE

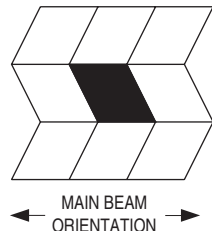
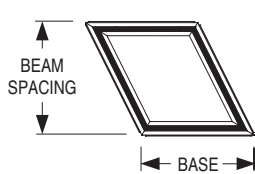

NOMINAL 60° PARALLELOGRAM, RIGHT

- 24" BEAM SPACING x 24" BASE

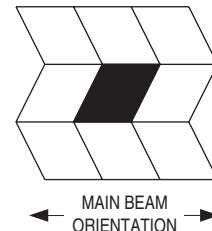
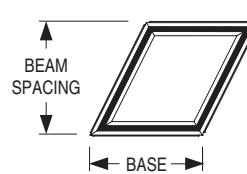

**SCHEDULE TYPE:**

**PROJECT:**

**ENGINEER:**

**CONTRACTOR:**

Page 1 of 2  
Dimensions are in inches (mm).

**DATE**

**B SERIES**

**SUPERSEDES**

**DRAWING NO.**

7 - 15 - 22

FLH

3 - 28 - 22

FLH10-SHP



**FLOWLINE™ SHAPES SLOT DIFFUSERS**  
 ARCHITECTURAL • ALUMINUM  
 HORIZONTAL HIGH THROW PATTERN CONTROLLERS  
 MODEL SERIES: FLH10-SHP

**FLH Series Pattern Controller Adjustment**

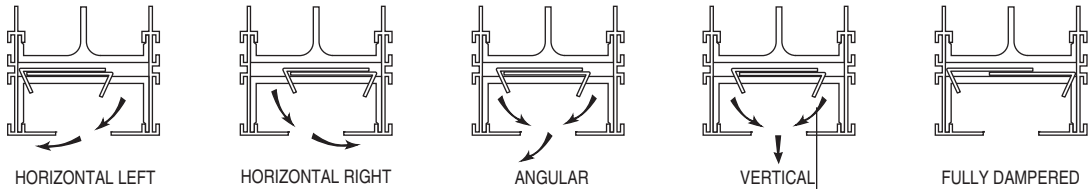

**Standard Mounting Style**  
 Frame/Border Type ATZ1 for 9/16" (14) Flat T-Bar Tegular Ceiling (Suprafine®)

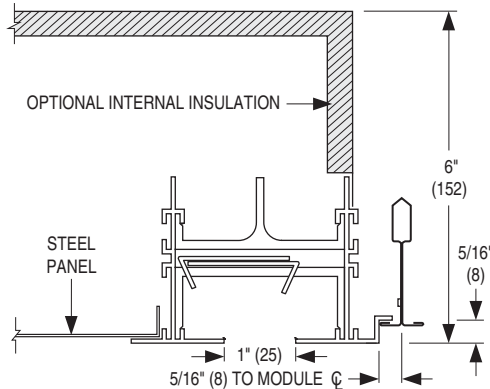

**Suprafine®**  
 T-Bar Detail

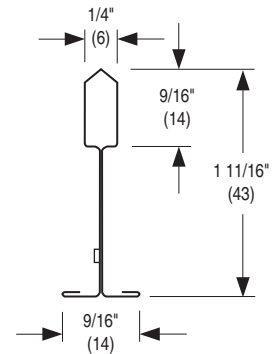

**Plenum Detail**

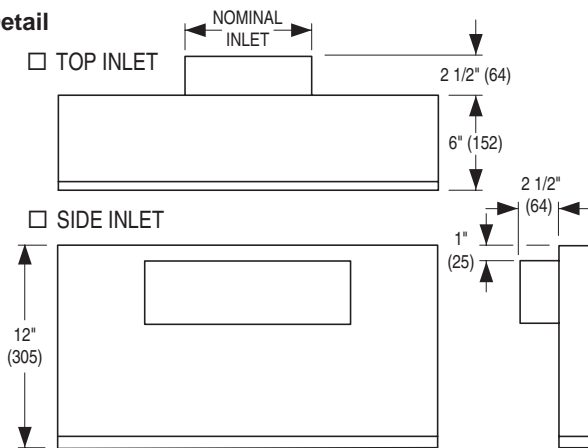

- LOCATED ON SHORT SIDE FOR 90° LEFT/RIGHT  
 - LOCATED ON BASE SIDE FOR ALL OTHER SHAPES

**Available Inlet Sizes**

**Top Inlet - Round**

Ceiling Module	Nominal Size
24 x 24 (610 x 610)	6, 8 (152, 203)
24 x 48 (610 x 1219)	8, 10 (203, 254)
48 x 24 (1219 x 610)	8, 10 (203, 254)
48 x 48 (1219 x 1219)	10, 12 (254, 305)

**Side Inlet - Rectangular**

Ceiling Module	Nominal Size
24 x 24 (610 x 610)	7 x 4 (178 x 102), 13 x 4 (330 x 102)
24 x 48 (610 x 1219)	13 x 4 (330 x 102), 13 x 6 (330 x 152)
48 x 24 (1219 x 610)	13 x 4 (330 x 102), 13 x 6 (330 x 152)
48 x 48 (1219 x 1219)	13 x 6 (330 x 152), 19 x 6 (483 x 152)

**Description:**

- Extruded aluminum frame and spacers with corrosion resistant steel pattern controllers. Plenum is coated steel.
- 1" (25) slot width.
- Factory precision welding on all mitered corners. Mitered corner sections are inactive.
- Standard finish is AW Appliance White face w/black pattern controllers. Other finishes available.

**Notes:**

- By adjusting pattern controllers; the flow from each side may be redirected or closed off.
- Armstrong®, Designflex™ and Suprafine® are trademarks of AWI Licensing LLC.

**Options:**

- FGI 1/4" (6.35) coated fiberglass internal insulation.

**Finish:**

- BW British White face with black pattern controllers.
- SP Custom Matched Color face with black pattern controllers.

**SCHEDULE TYPE:**

**PROJECT:**

**ENGINEER:**

**CONTRACTOR:**

Page 2 of 2  
 Dimensions are in inches (mm).

DATE	B SERIES	SUPERSEDES	DRAWING NO.
7 - 15 - 22	FLH	3 - 28 - 22	FLH10-SHP



**FLOWLINE™ LINEAR SLOT DIFFUSERS**  
**ARCHITECTURAL • ALUMINUM**  
**HORIZONTAL HIGH THROW PATTERN CONTROLLERS**  
**MODEL SERIES: FLH TYPES CC, CCA, CCC & CCCA**

**CONCEALED SURFACE MOUNT APPLICATION • DRYWALL (CEILING/WALL) TAPE & SPACKLE**

**One Slot**

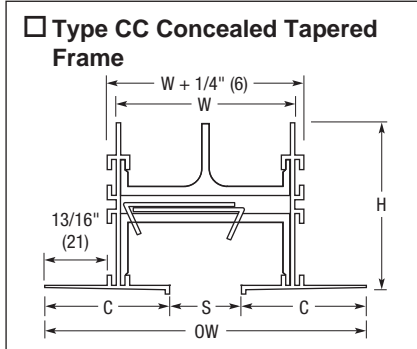

**Two Slot**

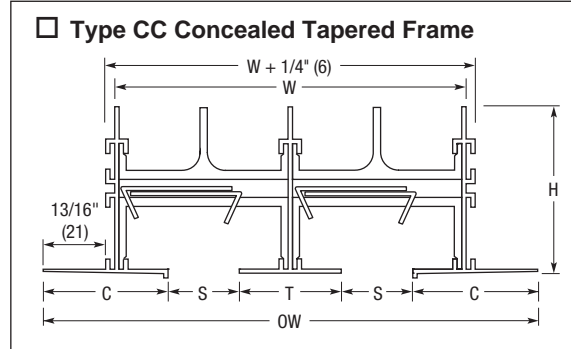

**End Condition**

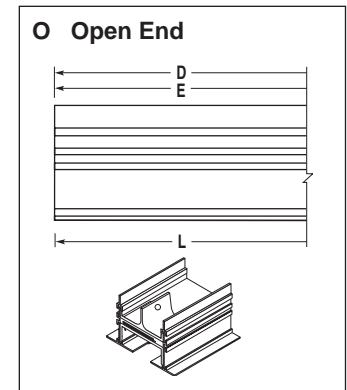
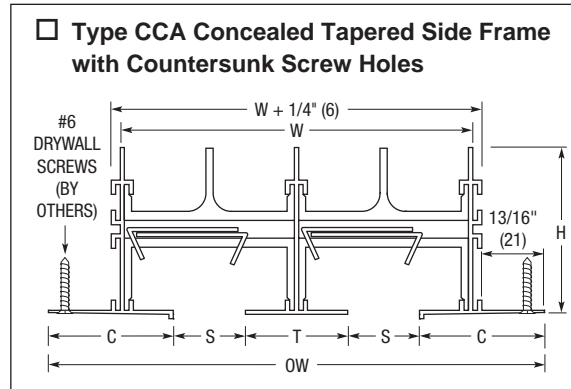
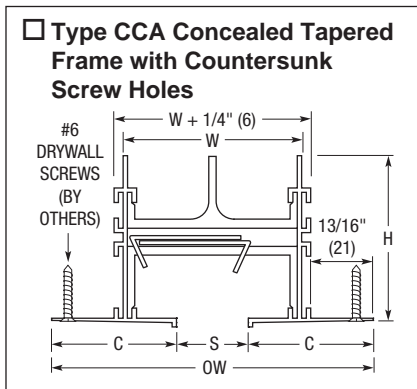
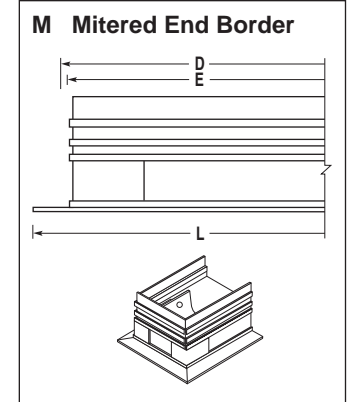

**Dimensional Data - Imperial (Metric) Units**

Model	S Slot Width	1 Slot		2 Slot		C Border Width	H Height	T 2 Slot
		W	OW	W	OW			
FLH10	1 (25)	2 1/2 (64)	4 3/8 (111)	4 15/16 (125)	6 13/16 (173)	1 11/16 (43)	2 3/8 (60)	1 7/16 (37)
FLH15	1 1/2 (38)	3 1/2 (89)	5 3/8 (137)	6 15/16 (176)	8 13/16 (224)	1 15/16 (49)	2 5/8 (67)	1 15/16 (49)
FLH20	2 (51)	4 1/2 (114)	6 3/8 (162)	8 15/16 (227)	10 13/16 (275)	2 3/16 (56)	2 7/8 (73)	2 7/16 (62)
FLH25	2 1/2 (64)	5 1/2 (140)	7 3/8 (187)	10 15/16 (278)	12 13/16 (325)	2 7/16 (62)	3 1/8 (79)	2 15/16 (75)
FLH30	3 (76)	6 1/2 (165)	8 3/8 (213)	12 15/16 (329)	14 13/16 (376)	2 11/16 (68)	3 3/8 (86)	3 7/16 (87)

**Notes:**

- Material: Heavy duty extruded aluminum frame and spacers. Corrosion resistant steel pattern controllers.
- Maximum section length is 72" (1823) by default. 96" (2438) and 120" (3048) are available as options. Lengths longer than the maximum section length are furnished in multiple sections with alignment strips, the number and size determined by the factory.
- Adjustable pattern controllers are on 24" (610) centers.
- MI Mill finish is standard on frame/border CC with an AW Appliance White center tee on the 2 slot model. Pattern controllers and interior surfaces are black.
- Type CC and CCA have integral hanger brackets on 24" (610) centers. See separate submittal for Type CC optional mounting hardware and accessories.

**Options:**

SP Special Finish \_\_\_\_\_.

**Overall Length and End Cap Position**

	E	L
<input type="checkbox"/> MM	D - 1/4 (6)	D + 1 3/8 (35)
<input type="checkbox"/> MO	D - 1/8 (3)	D + 11/16 (17)
<input type="checkbox"/> MC	D - 1/16 (2)	D + 3/4 (19)
<input type="checkbox"/> OO	D	D
<input type="checkbox"/> OC	D - 1/16 (2)	D - 1/16 (2)
<input type="checkbox"/> CC	D - 1/8 (3)	D - 1/8 (3)

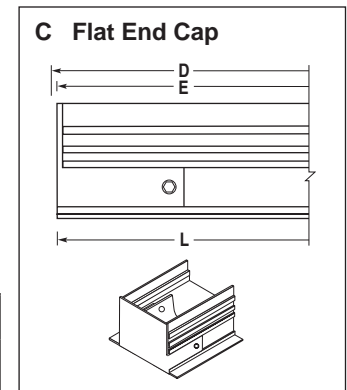

<b>SCHEDULE TYPE</b>	
<b>PROJECT</b>	
<b>ENGINEER</b>	
<b>CONTRACTOR</b>	

Page 1 of 2  
 Dimensions are in inches (mm).

<b>DATE</b>	<b>B SERIES</b>	<b>SUPERSEDES</b>	<b>DRAWING NO.</b>
12 - 19 - 22	FL	3 - 3 - 22	FLH-2A



**FLOWLINE™ LINEAR SLOT DIFFUSERS**  
 ARCHITECTURAL • ALUMINUM  
 HORIZONTAL HIGH THROW PATTERN CONTROLLERS  
 MODEL SERIES: FLH TYPES CC, CCA, CCC & CCCA

**One Slot**

**Type CCC Concealed Tapered Frame with Concealed Mounting Brackets**

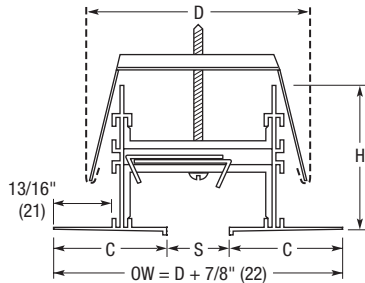

**Two Slot**

**Type CCC Concealed Tapered Side Frame with Concealed Mounting Brackets**

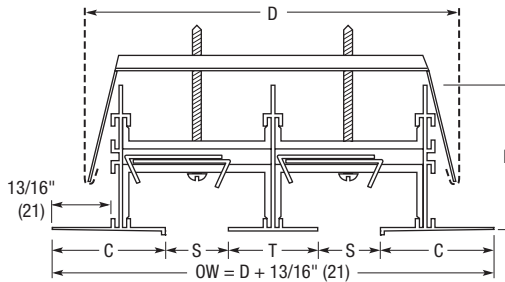

**End Condition**

**M Mitered End Border**

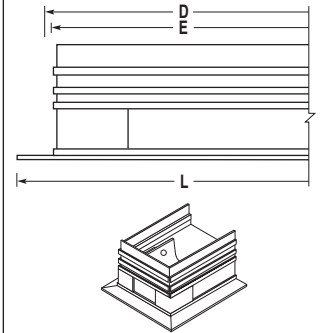

**Type CCCA Concealed Tapered Frame with Concealed Mounting Brackets & Countersunk Screw Holes**

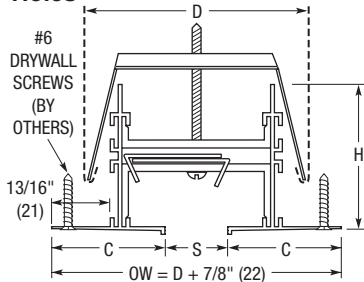

**Type CCCA Concealed Tapered Side Frame with Concealed Mounting Brackets & Countersunk Screw Holes**

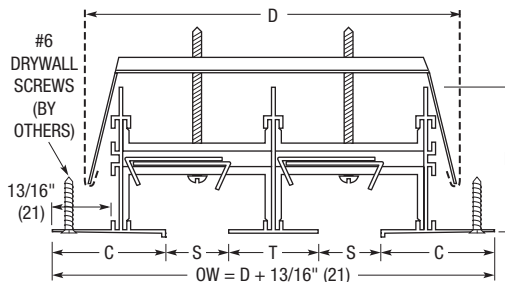

**O Open End**

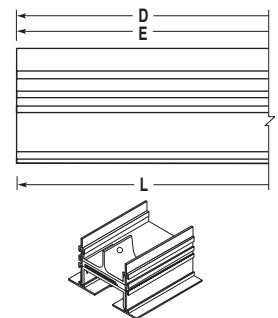

**Dimensional Data - Imperial (Metric) Units**

Model	S Slot Width	D Duct Width		C Border Width	H Height	T 2 Slot	Ceiling Opening Width	
		1 Slot	2 Slot				1 Slot	2 Slot
FLH10	1 (25)	3 1/2 (89)	6 (152)	1 11/16 (43)	2 3/8 (60)	1 7/16 (37)	3 (76)	5 1/2 (140)
FLH15	1 1/2 (38)	4 1/2 (114)	8 (203)	1 15/16 (49)	2 5/8 (67)	1 15/16 (49)	4 (102)	7 1/2 (191)
FLH20	2 (51)	5 1/2 (140)	10 (254)	2 3/16 (56)	2 7/8 (73)	2 7/16 (62)	5 (127)	9 1/2 (241)
FLH25	2 1/2 (64)	6 1/2 (165)	12 (305)	2 7/16 (62)	3 1/8 (79)	2 15/16 (75)	6 (152)	11 1/2 (292)
FLH30	3 (76)	7 1/2 (191)	14 (356)	2 11/16 (68)	3 3/8 (86)	3 7/16 (87)	7 (178)	13 1/2 (343)

**Notes:**

- Material: Heavy duty extruded aluminum frame and spacers. Corrosion resistant steel pattern controllers.
- Maximum section length is 72" (1823) by default. 96" (2438) and 120" (3048) are available as options. Lengths longer than the maximum section length are furnished in multiple sections with alignment strips, the number and size determined by the factory.
- Adjustable pattern controllers are on 24" (610) centers.
- MI Mill finish is standard on frame/borders CCC and CCCA with an AW Appliance White center tee on the 2 slot model. Pattern controllers and interior surfaces are black.
- Types CCC and CCCA are supplied with concealed mounting brackets and leveling screws on 24" (610) centers. See separate submittal for accessories.

**Overall Length and End Cap Position**

	E	L
<input type="checkbox"/> MM	D - 1/4 (6)	D + 1 3/8 (35)
<input type="checkbox"/> MO	D - 1/8 (3)	D + 11/16 (17)
<input type="checkbox"/> MC	D - 1/16 (2)	D + 3/4 (19)
<input type="checkbox"/> OO	D	D
<input type="checkbox"/> OC	D - 1/16 (2)	D - 1/16 (2)
<input type="checkbox"/> CC	D - 1/8 (3)	D - 1/8 (3)

**C Flat End Cap**

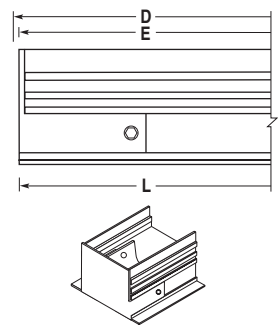

**Options:**

SP Special Finish \_\_\_\_\_.

**SCHEDULE TYPE**

**PROJECT**

**ENGINEER**

**CONTRACTOR**

Page 2 of 2  
 Dimensions are in inches (mm).

**DATE**

**B SERIES**

**SUPERSEDES**

**DRAWING NO.**

12 - 19 - 22

FL

3 - 3 - 22

FLH-2A



**FLOWLINE™ LINEAR SLOT DIFFUSERS**  
**ARCHITECTURAL • ALUMINUM**  
**MODEL SERIES: FLH AND FLV TYPE CA**

**FLH Horizontal High Throw Pattern Controllers**

**One Slot**

**Type CA Concealed Tapered/ Exposed Flange Frame**

- Tape and Spackle (one side)
- Drywall (ceiling)

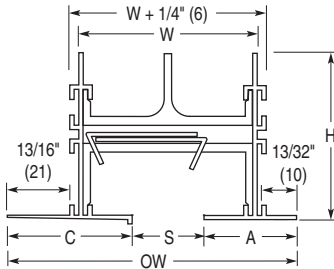

**Two Slot**

**Type CA Concealed Tapered/ Exposed Flange Frame**

- Tape and Spackle (one side)
- Drywall (ceiling)

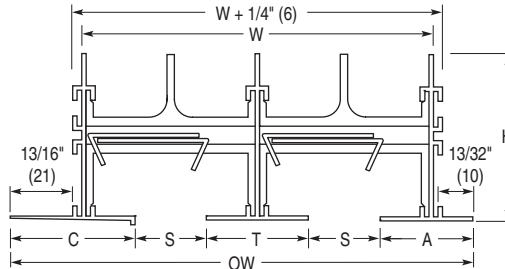

**End Condition**

**O Open End**

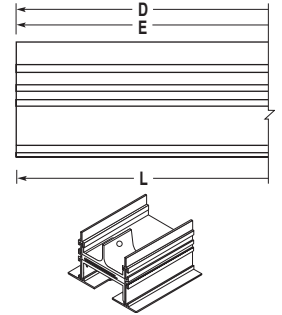

**C Flat End Cap**

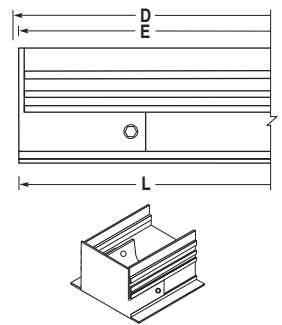

**FLV Vertical Jet Throw Pattern Controllers**

**One Slot**

**Type CA Concealed Tapered/ Exposed Flange Frame**

- Tape and Spackle (one side)
- Drywall (ceiling)

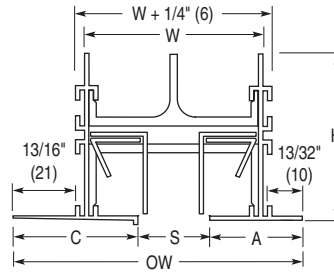

**Two Slot**

**Type CA Concealed Tapered/ Exposed Flange Frame**

- Tape and Spackle (one side)
- Drywall (ceiling)

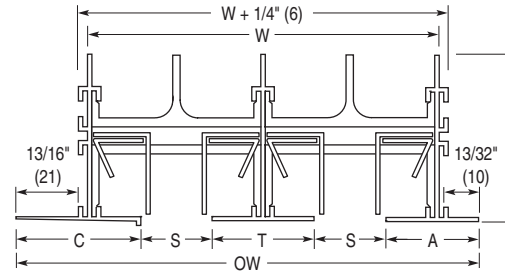

**Dimensional Data - Imperial (Metric) Units**

Model	S Slot Width	1 Slot		2 Slot		C Border Width	A Border Width	H Height	T 2 Slot
		W	OW	W	OW				
FLH10, FLV10	1 (25)	2 1/2 (64)	3 31/32 (101)	4 15/16 (125)	6 13/32 (163)	1 11/16 (43)	1 9/32 (33)	2 3/8 (60)	1 7/16 (37)
FLH15, FLV15	1 1/2 (38)	3 1/2 (89)	4 31/32 (126)	6 15/16 (176)	8 13/32 (214)	1 15/16 (49)	1 17/32 (39)	2 5/8 (67)	1 15/16 (49)
FLH20, FLV20	2 (51)	4 1/2 (114)	5 31/32 (152)	8 15/16 (227)	10 13/32 (264)	2 3/16 (56)	1 25/32 (45)	2 7/8 (73)	2 7/16 (62)
FLH25, FLV25	2 1/2 (64)	5 1/2 (140)	6 31/32 (177)	10 15/16 (278)	12 13/32 (315)	2 7/16 (62)	2 1/32 (52)	3 1/8 (79)	2 15/16 (75)
FLH30, FLV30	3 (76)	6 1/2 (165)	7 31/32 (202)	12 15/16 (329)	14 13/32 (366)	2 11/16 (68)	2 9/32 (58)	3 3/8 (86)	3 7/16 (87)

**Notes:**

1. Material: Heavy duty extruded aluminum frame and spacers. Corrosion resistant steel pattern controllers.
2. Maximum section length is 72" (1823) by default. 96" (2438) and 120" (3048) are available as options. Lengths longer than the maximum section length are furnished in multiple sections with alignment strips, the number and size determined by the factory.
3. Adjustable pattern controllers are on 24" (610) centers.
4. MI Mill finish is standard on frame/border C with an AW Appliance White finish on frame/border A and center tee on the 2 slot model. Pattern controllers and interior surfaces are black.
5. Integral hanger brackets on 24" (610) centers. See separate submittal for optional mounting hardware and accessories.

**Options:**

- SP Special Finish \_\_\_\_\_.

**Overall Length and End Cap Position**

	E	L
<input type="checkbox"/> OO	D	D
<input type="checkbox"/> OC	D - 1/16 (2)	D - 1/16 (2)
<input type="checkbox"/> CC	D - 1/8 (3)	D - 1/8 (3)

**SCHEDULE TYPE**

**PROJECT**

**ENGINEER**

**CONTRACTOR**

Dimensions are in inches (mm).

**DATE**

**B SERIES**

**SUPERSEDES**

**DRAWING NO.**

3 - 3 - 22

FL

9 - 26 - 18

FLH-2C



**FLOWLINE™ LINEAR SLOT DIFFUSERS**  
**ARCHITECTURAL • ALUMINUM**  
**HORIZONTAL JET THROW PATTERN CONTROLLERS**  
**MODEL SERIES: FLH TYPES GG & AG**

**One Slot**

- Type GG Flangeless Frame**  
• Drywall (ceiling, wall)

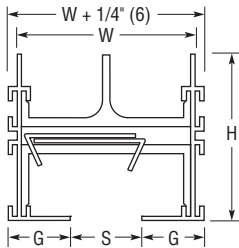

- Type AG Flange / Flangeless Frame**  
• Drywall (ceiling, wall)

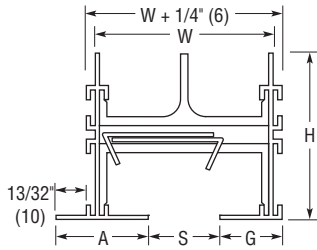

**Two Slot**

- Type GG Flangeless Frame**  
• Drywall (ceiling, wall)

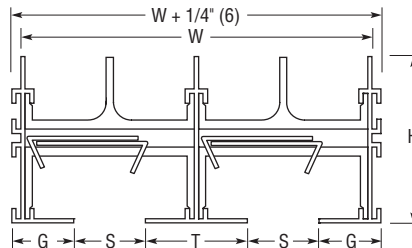

- Type AG Flange / Flangeless Frame**  
• Drywall (ceiling, wall)

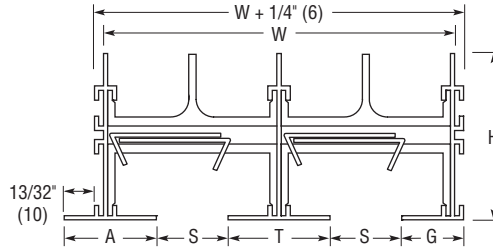

**End Condition**

- F Flanged End Cap**

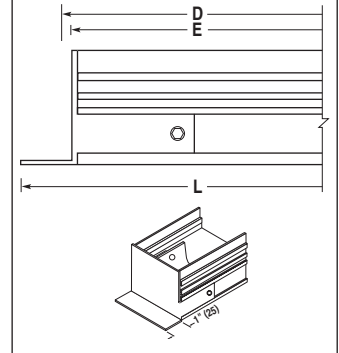

- O Open End**

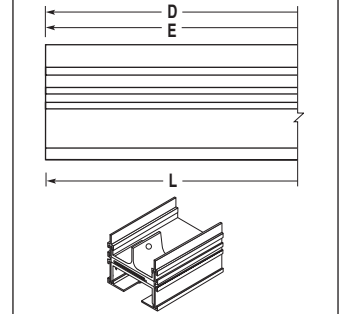

- C Flat End Cap**

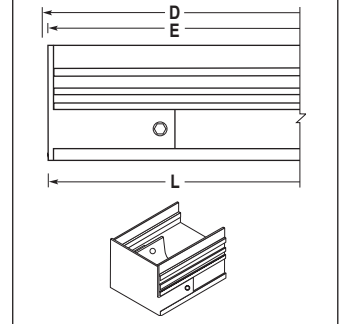

**Dimensional Data - Imperial (Metric) Units**

Model	S Slot Width	1 Slot W	2 Slot W	A Border Width	G Border Width	H Height	T 2 Slot
FLH10	1 (25)	2 1/2 (64)	4 15/16 (125)	1 9/32 (33)	7/8 (22)	2 3/8 (60)	1 7/16 (37)
FLH15	1 1/2 (38)	3 1/2 (89)	6 15/16 (176)	1 17/32 (39)	1 1/8 (29)	2 5/8 (67)	1 15/16 (49)
FLH20	2 (51)	4 1/2 (114)	8 15/16 (227)	1 25/32 (45)	1 3/8 (35)	2 7/8 (73)	2 7/16 (62)
FLH25	2 1/2 (64)	5 1/2 (140)	10 15/16 (278)	2 1/32 (52)	1 5/8 (41)	3 1/8 (79)	2 15/16 (75)
FLH30	3 (76)	6 1/2 (165)	12 15/16 (329)	2 9/32 (58)	1 7/8 (48)	3 3/8 (86)	3 7/16 (87)

**Notes:**

- Material: Heavy duty extruded aluminum frame and spacers. Corrosion resistant steel pattern controllers.
- Maximum section length is 72" (1823) by default. 96" (2438) and 120" (3048) are available as options. Lengths longer than the maximum section length are furnished in multiple sections with alignment strips, the number and size determined by the factory.
- Adjustable pattern controllers are on 24" (610) centers.
- Standard finish is AW Appliance White baked enamel on exposed frames with black pattern controllers and interior surfaces.
- Integral hanger brackets on 24" (610) centers. See separate submittal for optional mounting hardware and accessories.

**Options:**

- SP Special Finish \_\_\_\_\_.

**Overall Length and End Cap Position**

	E	L
<input type="checkbox"/> 00	D	D
<input type="checkbox"/> 0C	D - 1/16 (2)	D - 1/16 (2)
<input type="checkbox"/> CC	D - 1/8 (3)	D - 1/8 (3)
<input type="checkbox"/> FF	D - 1/4 (6)	D + 1 5/8 (41)
<input type="checkbox"/> FO	D - 1/8 (3)	D + 13/16 (21)
<input type="checkbox"/> FC	D - 1/16 (2)	D + 7/8 (22)

**SCHEDULE TYPE**

**PROJECT**

**ENGINEER**

**CONTRACTOR**

Dimensions are in inches (mm).

**DATE**

**B SERIES**

**SUPERSEDES**

**DRAWING NO.**

3 - 3 - 22

FL

2 - 16 - 10

FLH-3



**FLOWLINE™ LINEAR SLOT DIFFUSERS**  
**ARCHITECTURAL • ALUMINUM**  
**HORIZONTAL HIGH THROW PATTERN CONTROLLERS**  
**MODEL SERIES: FLH TYPE GJ**

**One Slot**

- Type GJ Exposed/Concealed Offset Frame**
- Drywall (ceiling, wall)

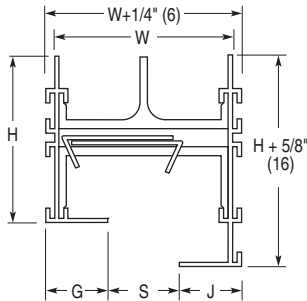

**End Condition**

**O Open End**

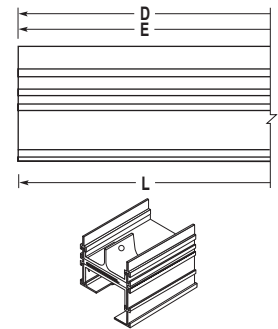

**C Flat End Cap**

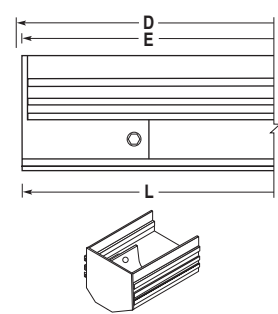

**Dimensional Data - Imperial (Metric) Units**

Model	S Slot Width	1 Slot W	G Border Width	J Border Width	H Height
FLH10	1 (25)	2 1/2 (64)	7/8 (22)	7/8 (22)	2 3/8 (60)
FLH15	1 1/2 (38)	3 1/2 (89)	1 1/8 (29)	1 1/8 (29)	2 5/8 (67)
FLH20	2 (51)	4 1/2 (114)	1 3/8 (35)	1 3/8 (35)	2 7/8 (73)
FLH25	2 1/2 (64)	5 1/2 (140)	1 5/8 (41)	1 5/8 (41)	3 1/8 (79)
FLH30	3 (76)	6 1/2 (165)	1 7/8 (48)	1 7/8 (48)	3 3/8 (86)

**Overall Length and End Cap Position**

	E	L
<input type="checkbox"/> OO	D	D
<input type="checkbox"/> OC	D - 1/16 (2)	D - 1/16 (2)
<input type="checkbox"/> CC	D - 1/8 (3)	D - 1/8 (3)

**Notes:**

1. Material: Heavy duty extruded aluminum frame and spacers. Corrosion resistant steel pattern controllers.
2. Maximum section length is 72" (1823) by default. 96" (2438) and 120" (3048) are available as options. Lengths longer than the maximum section length are furnished in multiple sections with alignment strips, the number and size determined by the factory.
3. Adjustable pattern controllers are on 24" (610) centers.
4. Standard finish is AW Appliance White on exposed frames. Pattern controllers and interior surfaces are black.
5. Integral hanger brackets on 24" (610) centers. See separate submittal for optional mounting hardware and accessories.

**Options:**

- SP Special Finish \_\_\_\_\_.

**SCHEDULE TYPE**

**PROJECT**

**ENGINEER**

**CONTRACTOR**

Dimensions are in inches (mm).

**DATE**

**B SERIES**

**SUPERSEDES**

**DRAWING NO.**

3 - 3 - 22

FL

8 - 1 - 17

FLH-3B





**FLOWLINE™ LINEAR SLOT DIFFUSERS**  
**ARCHITECTURAL • ALUMINUM**  
**MODEL SERIES: FLH AND FLV TYPE KK**

**FLH Horizontal High Throw Pattern Controllers**

- Type KK Concealed Angular Frame**
- Drywall (ceiling, wall)

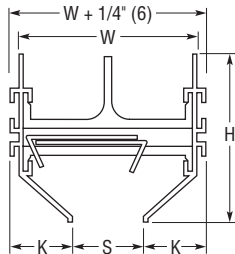

**FLV Vertical Jet Throw Pattern Controllers**

- Type KK Concealed Angular Frame**
- Drywall (ceiling, wall)

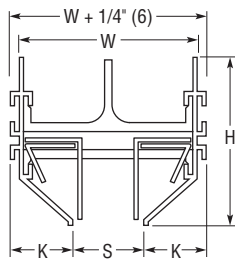

**End Condition**

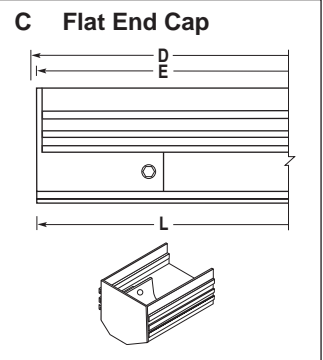
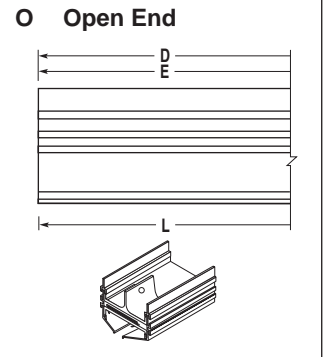

**Dimensional Data - Imperial (Metric) Units**

Model	S Slot Width	1 Slot W	K Border Width	H Height
FLH10, FLV10	1 (25)	2 1/2 (64)	7/8 (22)	2 3/8 (60)
FLH15, FLV15	1 1/2 (38)	3 1/2 (89)	1 1/8 (29)	2 5/8 (67)
FLH20, FLV20	2 (51)	4 1/2 (114)	1 3/8 (35)	2 7/8 (73)

**Notes:**

1. Material: Heavy duty extruded aluminum frame and spacers. Corrosion resistant steel pattern controllers.
2. Maximum section length is 72" (1823) by default. 96" (2438) and 120" (3048) are available as options. Lengths longer than the maximum section length are furnished in multiple sections with alignment strips, the number and size determined by the factory.
3. Adjustable pattern controllers are on 24" (610) centers.
4. Standard finish is MI Mill on exposed frames with black pattern controllers and interior surfaces.
5. Integral hanger brackets on 24" (610) centers. See separate submittal for optional mounting hardware and accessories.

**Options:**

- SP Special Finish \_\_\_\_\_ .

**Overall Length and End Cap Position**

	E	L
<input type="checkbox"/> OO	D	D
<input type="checkbox"/> OC	D - 1/16 (2)	D - 1/16 (2)
<input type="checkbox"/> CC	D - 1/8 (3)	D - 1/8 (3)

**SCHEDULE TYPE**

**PROJECT**

**ENGINEER**

**CONTRACTOR**

Dimensions are in inches (mm).

**DATE**

**B SERIES**

**SUPERSEDES**

**DRAWING NO.**

3 - 3 - 22

FL

5 - 10 - 18

FLH-3C



**FLOWLINE™ LINEAR SLOT DIFFUSERS**  
**ARCHITECTURAL • ALUMINUM**  
**MODEL SERIES: FLH AND FLV TYPE CG**

**FLH Horizontal High Throw Pattern Controllers**

**One Slot**

- Type CG Concealed Tapered/Flangeless Frame**
  - Tape and Spackle (one side)
  - Drywall (ceiling)

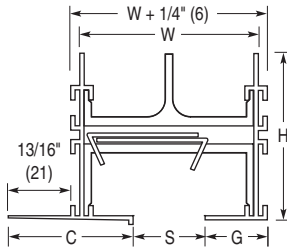

**Two Slot**

- Type CG Concealed Tapered/Flangeless Frame**
  - Tape and Spackle (one side)
  - Drywall (ceiling)

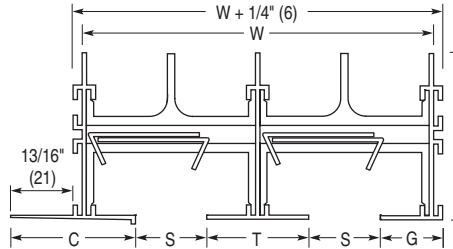

**FLV Vertical Jet Throw Pattern Controllers**

**One Slot**

- Type CG Concealed Tapered/Exposed Flange Frame**
  - Tape and Spackle (one side)
  - Drywall (ceiling)

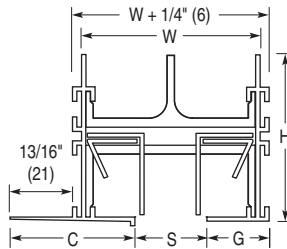

**Two Slot**

- Type CG Concealed Tapered/Exposed Flange Frame**
  - Tape and Spackle (one side)
  - Drywall (ceiling)

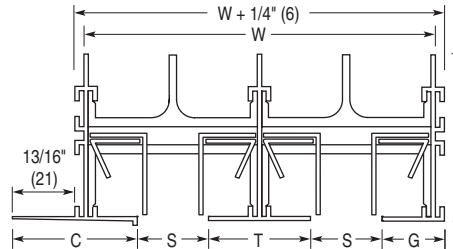

**Dimensional Data - Imperial (Metric) Units**

Model	S Slot Width	1 Slot	2 Slot	C Border Width	G Border Width	H Height	T 2 Slot
		W	W				
FLH10, FLV10	1 (25)	2 1/2 (64)	4 15/16 (125)	1 11/16 (43)	7/8 (22)	2 3/8 (60)	1 7/16 (37)
FLH15, FLV15	1 1/2 (38)	3 1/2 (89)	6 15/16 (176)	1 15/16 (49)	1 1/8 (29)	2 5/8 (67)	1 15/16 (49)
FLH20, FLV20	2 (51)	4 1/2 (114)	8 15/16 (227)	2 3/16 (56)	1 3/8 (35)	2 7/8 (73)	2 7/16 (62)
FLH25, FLV25	2 1/2 (64)	5 1/2 (140)	10 15/16 (278)	2 7/16 (62)	1 5/8 (41)	3 1/8 (79)	2 15/16 (75)
FLH30, FLV30	3 (76)	6 1/2 (165)	12 15/16 (329)	2 11/16 (68)	1 7/8 (48)	3 3/8 (86)	3 7/16 (87)

**Notes:**

1. Material: Heavy duty extruded aluminum frame and spacers. Corrosion resistant steel pattern controllers.
2. Maximum section length is 72" (1823) by default. 96" (2438) and 120" (3048) are available as options. Lengths longer than the maximum section length are furnished in multiple sections with alignment strips, the number and size determined by the factory.
3. Adjustable pattern controllers are on 24" (610) centers.

4. MI Mill finish is standard on frame/border C with an AW Appliance White finish on frame/border G and center tee on the 2 slot model. Pattern controllers and interior surfaces are black.
5. Integral hanger brackets on 24" (610) centers. See separate submittal for optional mounting hardware and accessories.

**Options:**

- SP Special Finish \_\_\_\_\_.

**End Condition**

**O Open End**

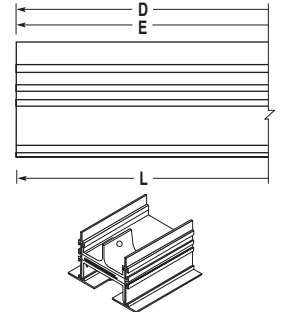

**C Flat End Cap**

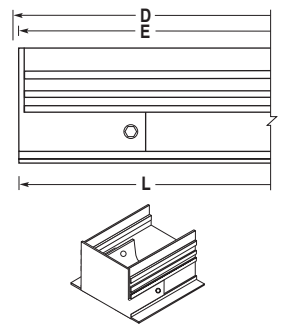

**Overall Length and End Cap Position**

	E	L
<input type="checkbox"/> OO	D	D
<input type="checkbox"/> OC	D - 1/16 (2)	D - 1/16 (2)
<input type="checkbox"/> CC	D - 1/8 (3)	D - 1/8 (3)

**SCHEDULE TYPE**

**PROJECT**

**ENGINEER**

**CONTRACTOR**

Dimensions are in inches (mm).

**DATE**

**B SERIES**

**SUPERSEDES**

**DRAWING NO.**

3 - 3 - 22

FL

9 - 26 - 18R

FLH-3F



**FLOWLINE™ LINEAR SLOT DIFFUSERS**  
**ACCESSORIES**  
**SUPPLY AIR ENGINEERED PLENUMS**  
**MODEL SERIES: FLP**

**Uninsulated Models:**

- FLP10 • 1" (25) Slot
- FLP15 • 1 1/2" (38) Slot
- FLP20 • 2" (51) Slot
- FLP25 • 2 1/2" (64) Slot
- FLP30 • 3" (76) Slot

**Internally Insulated Models:**

- FLPI10 • 1" (25) Slot
- FLPI15 • 1 1/2" (38) Slot
- FLPI20 • 2" (51) Slot
- FLPI25 • 2 1/2" (64) Slot
- FLPI30 • 3" (76) Slot

**Flowline™ Plenum**

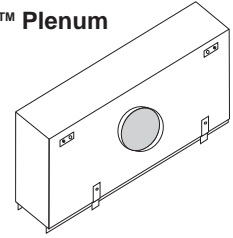

- Straight Leg (Direct Attachment)**  
 For use with Frame / Border Types  
**AA, CA, CC, CCA, CG, GG, GJ,  
 KK, LT, NT**

**Plenum Height (HS):**  
 One Slot 10" (254)  
 Two Slot 16" (406)

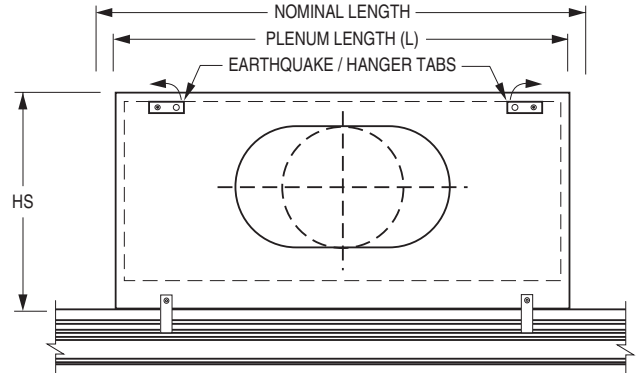
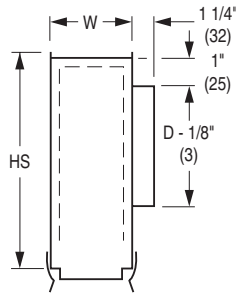

- Hemmed Leg (For concealed mounting bracket)**  
 For use with Frame / Border Types  
**AAC, CCC, CCCA**

**Plenum Height (HH):**  
 One Slot 12" (305)  
 Two Slot 18" (457)

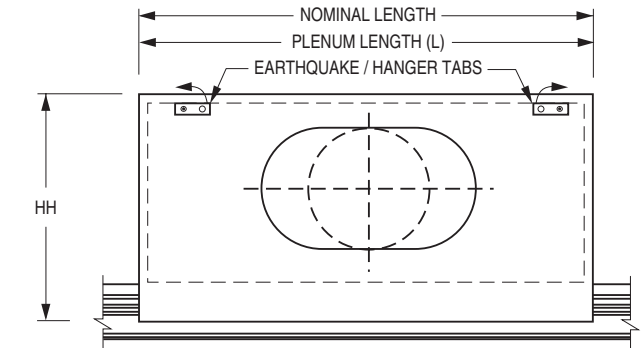
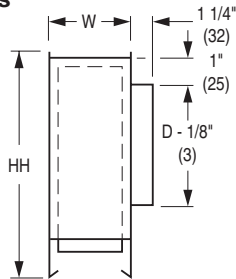

**Dimensional Data**

Nominal Length	Actual Plenum Length (L) for Frame/Border Type		Available Inlet Sizes D	
	AA, CA, CC, CCA, CG, GG, GJ, KK, LT, NT	AAC, CCC, CCCA	1 Slot	2 Slot
24 (610)	20 3/4 (527)	24 (610)	6 (152), 8 (203)	6 (152), 8 (203), Round
30 (762)	26 3/4 (679)	30 (762)	10 (254), 12 (305), 14 (356)	10 (254), 12 (305), 14 (356) Round
36 (914)	32 3/4 (832)	36 (914)	14 (356)	Round
48 (1219)	44 3/4 (1137)	48 (1219)	Flat Oval*	
60 (1524)	56 3/4 (1441)	60 (1524)		
72 (1829)	68 3/4 (1746)	72 (1829)		

Plenum Model	Width (W) for Frame/Border Type Noted			
	AA, CA, CC, CCA, CG, GG, GJ, KK, LT, NT		AAC, CCC, CCCA	
	1 Slot	2 Slot	1 Slot	2 Slot
FLP(I)10	2 3/4 (70)	5 3/16 (132)	3 1/2 (89)	5 15/16 (151)
FLP(I)15	3 3/4 (95)	7 3/16 (183)	4 1/2 (114)	7 15/16 (202)
FLP(I)20	4 3/4 (121)	9 3/16 (233)	5 1/2 (140)	9 15/16 (252)
FLP(I)25	5 3/4 (146)	11 3/16 (284)	6 1/2 (165)	11 15/16 (303)
FLP(I)30	6 3/4 (171)	13 3/16 (335)	7 1/2 (191)	13 15/16 (354)

\* **Equivalent Oval:** 10" (254) = 11" x 7 7/8" (279 x 200); 12" (305) = 14 1/8" x 7 7/8" (359 x 200); 14" (356) = 17 5/16" x 7 7/8" (440 x 200).

**Notes:**

1. Heavy gauge corrosion resistant steel construction.
2. Earthquake tabs are standard.
3. Straight leg plenums are supplied with spring clips.

**Options:**

- EX External Foil Back Insulation.
- ID ID Inlet damper.
- NI No Inlet.

**SCHEDULE TYPE**

**PROJECT**

**ENGINEER**

**CONTRACTOR**

Dimensions are in inches (mm).

**DATE**

**B SERIES**

**SUPERSEDES**

**DRAWING NO.**

4 - 13 - 21

FL

2 - 23 - 21

FLP-1



**FLOWLINE™ LINEAR DIFFUSER PLENUMS WITH  
CABLE OPERATED INLET DAMPER  
FLOWLINE™ LINEAR SLOT DIFFUSER ACCESSORY  
MODEL SERIES: FLP WITH IDCO OPTION**

**Uninsulated Models:**

- FLP10 • 1" (25) Slot
- FLP15 • 1 1/2" (38) Slot
- FLP20 • 2" (51) Slot
- FLP25 • 2 1/2" (64) Slot
- FLP30 • 3" (76) Slot

**Internally Insulated Models:**

- FLPI10 • 1" (25) Slot
- FLPI15 • 1 1/2" (38) Slot
- FLPI20 • 2" (51) Slot
- FLPI25 • 2 1/2" (64) Slot
- FLPI30 • 3" (76) Slot

**Flowline™ Plenum**

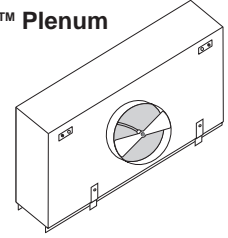

- Straight Leg (Direct Attachment)**  
For use with Frame / Border Types AA, CA, CC, CCA, CG, GG, GJ, KK, LT, NT

Inlet Size D (Round)	Plenum Height HS	
	1 Slot	2 Slot
6 (152), 8 (203)	10 (254)	16 (406)
10 (254)	13 (330)	16 (406)
12 (305)	15 (381)	16 (406)
14 (356)	17 (432)	17 (432)

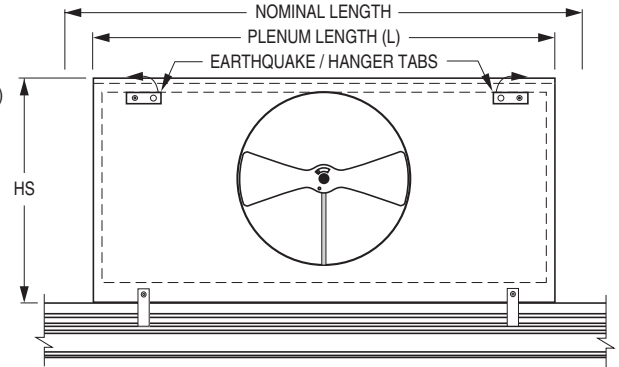
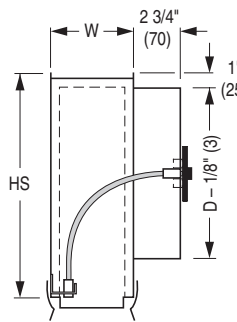

- Hemmed Leg (For concealed mounting bracket)**  
For use with Frame / Border Types AAC, CCC, CCCA

Inlet Size D (Round)	Plenum Height HH	
	1 Slot	2 Slot
6 (152), 8 (203)	12 (305)	18 (457)
10 (254)	13 (330)	18 (457)
12 (305)	15 (381)	18 (457)
14 (356)	17 (432)	18 (457)

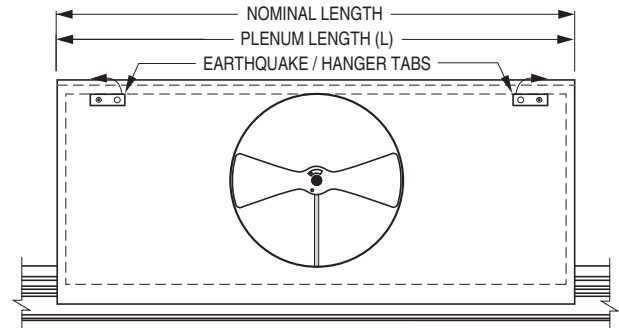
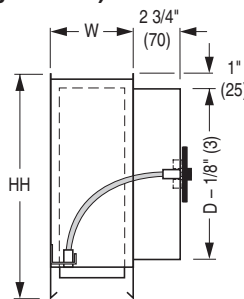

**Dimensional Data**

Nominal Length	Actual Plenum Length (L) for Frame/Border Type	
	AA, CA, CC, CCA, CG, GG, GJ, KK, LT, NT	AAC, CCC, CCCA
24 (610)	20 3/4 (527)	24 (610)
30 (762)	26 3/4 (679)	30 (762)
36 (914)	32 3/4 (832)	36 (914)
48 (1219)	44 3/4 (1137)	48 (1219)
60 (1524)	56 3/4 (1441)	60 (1524)
72 (1829)	68 3/4 (1746)	72 (1829)

Plenum Model	Width (W) for Frame/Border Type Noted			
	AA, CA, CC, CCA, CG, GG, GJ, KK, LT, NT		AAC, CCC, CCCA	
	1 Slot	2 Slot	1 Slot	2 Slot
FLP(l)10	2 3/4 (70)	5 3/16 (132)	3 1/2 (89)	5 15/16 (151)
FLP(l)15	3 3/4 (95)	7 3/16 (183)	4 1/2 (114)	7 15/16 (202)
FLP(l)20	4 3/4 (121)	9 3/16 (233)	5 1/2 (140)	9 15/16 (252)
FLP(l)25	5 3/4 (146)	11 3/16 (284)	6 1/2 (165)	11 15/16 (303)
FLP(l)30	6 3/4 (171)	13 3/16 (335)	7 1/2 (191)	13 15/16 (354)

**Notes:**

- Heavy gauge corrosion-resistant steel construction.
- Earthquake tabs are standard.
- Straight leg plenums are supplied with spring clips.
- The round inlet damper is Nailor's 4250 radial sliding blade design factory mounted on the inlet. A flexible rotary cable connects the damper to a Phillips head screw operator mounted inside the plenum that permits air balancing at the diffuser face.

**Options:**

- EX External Foil Back Insulation.

Dimensions are in inches (mm).

<b>SCHEDULE TYPE</b>			
<b>PROJECT</b>			
<b>ENGINEER</b>	<b>DATE</b>	<b>B SERIES</b>	<b>SUPERSEDES</b>
<b>CONTRACTOR</b>	4 - 13 - 21	FL	1 - 26 - 21
			<b>DRAWING NO.</b> FLP-2

**AVAILABLE SHAPES FOR ARMSTRONG® DESIGNFLEX™ CEILINGS**

(All views are face views.)

**Triangles**
**NOMINAL 60° TRIANGLE**

- 24" BEAM SPACING x 24" BASE
- 48" BEAM SPACING x 48" BASE

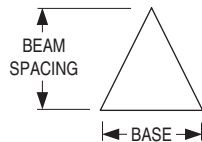
**NOMINAL 45° TRIANGLE**

- 24" BEAM SPACING x 48" BASE

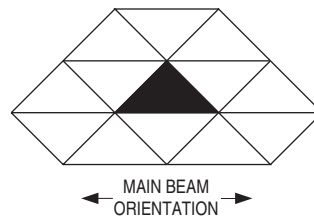
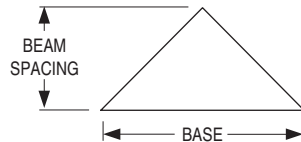
**NOMINAL 75° TRIANGLE**

- 48" BEAM SPACING x 24" BASE

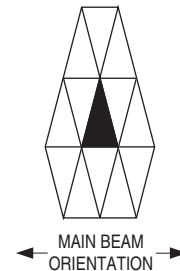
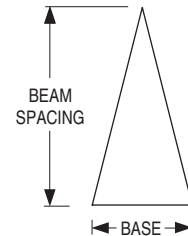
**90° TRIANGLE, LEFT**

- 24" BEAM SPACING x 48" BASE

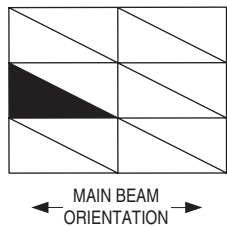
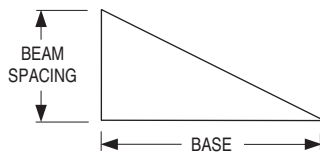
**90° TRIANGLE, RIGHT**

- 24" BEAM SPACING x 48" BASE

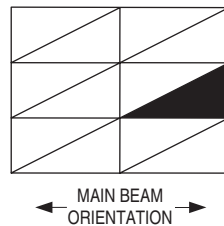
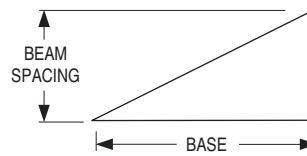
**90° TRIANGLE, SYMMETRICAL**

- 24" BEAM SPACING x 24" BASE
- 48" BEAM SPACING x 48" BASE

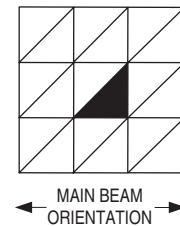
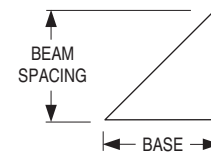
**Parallelograms**
**NOMINAL 60° PARALLELOGRAM, LEFT**

- 24" BEAM SPACING x 24" BASE

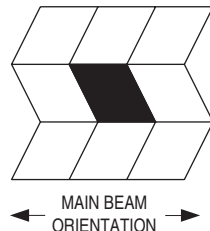
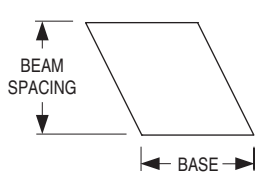
**NOMINAL 60° PARALLELOGRAM, RIGHT**

- 24" BEAM SPACING x 24" BASE

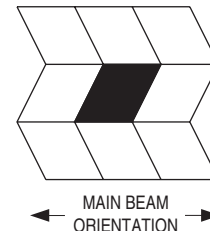
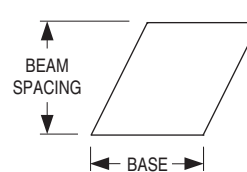
**SCHEDULE TYPE:**
**PROJECT:**
**ENGINEER:**
**CONTRACTOR:**

 Page 1 of 2  
 Dimensions are in inches (mm).

**DATE**
**B SERIES**
**SUPERSEDES**
**DRAWING NO.**

7 - 15 - 22

FLR

3 - 28 - 22

FLPR-SHP



**FLOWLINE™ SHAPES PERFORATED RETURNS**  
**ARCHITECTURAL • RETURN PANEL**  
**MODELS: FLPR-SHP AND FLPR-SHPA**

**Standard Mounting Style**  
**Panel for 9/16" (14) Flat T-Bar Tegular Ceiling (Suprafine®)**

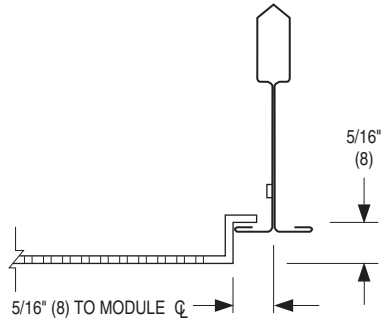

**Suprafine®**  
**T-Bar Detail**

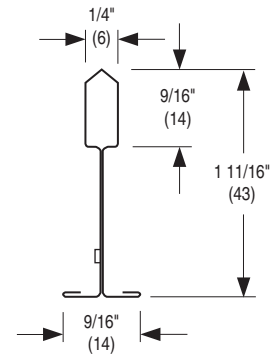

**Description:**

1. Material: Corrosion-resistant steel.
2. For use with ARMSTRONG® DESIGNFLEX™ SHAPES ceiling systems.
3. Standard finish is AW Appliance White.

**Notes:**

1. Armstrong®, Designflex™ and Suprafine® are trademarks of AWI Licensing LLC.

**Options:**

- Aluminum construction (Model FLPR-SHPA).
- SS Sight shield.

**Finish:**

- BW British White.
- SP Special Finish \_\_\_\_\_ .

<b>SCHEDULE TYPE:</b>		Page 2 of 2 Dimensions are in inches (mm).			
<b>PROJECT:</b>					
<b>ENGINEER:</b>	<b>DATE</b>	<b>B SERIES</b>	<b>SUPERSEDES</b>	<b>DRAWING NO.</b>	
<b>CONTRACTOR:</b>	7 - 15 - 22	FLR	3 - 28 - 22	FLPR-SHP	



**FLOWLINE™ LINEAR SLOT DIFFUSERS**  
**ARCHITECTURAL • ALUMINUM**  
**RETURN (NO PATTERN CONTROLLERS)**  
**MODEL SERIES: FLR TYPES AA & AAC**

**One Slot**

- Type AA Exposed Flange Frame**
- Drywall (ceiling, wall), T-Bar

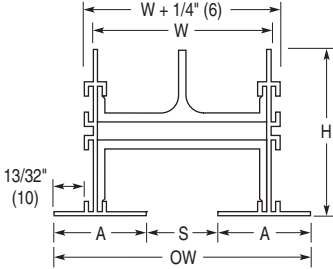

**Two Slot**

- Type AA Exposed Flange Frame**
- Drywall (ceiling, wall), T-Bar

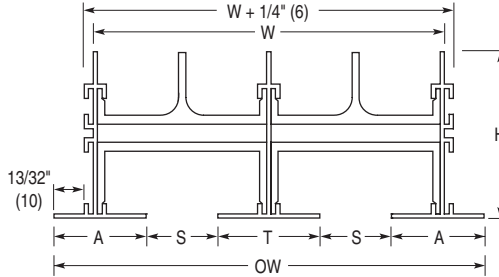

**Dimensional Data - Imperial (Metric) Units**

Model	S Slot Width	1 Slot		2 Slot		A Border Width	H Height	T 2 Slot
		W	OW	W	OW			
FLR10	1 (25)	2 1/2 (64)	3 9/16 (90)	4 15/16 (125)	6 (152)	1 9/32 (33)	2 3/8 (60)	1 7/16 (37)
FLR15	1 1/2 (38)	3 1/2 (89)	4 9/16 (116)	6 15/16 (176)	8 (203)	1 17/32 (39)	2 5/8 (67)	1 15/16 (49)
FLR20	2 (51)	4 1/2 (114)	5 9/16 (141)	8 15/16 (227)	10 (254)	1 25/32 (45)	2 7/8 (73)	2 7/16 (62)
FLR25	2 1/2 (64)	5 1/2 (140)	6 9/16 (167)	10 15/16 (278)	12 (305)	2 1/32 (52)	3 1/8 (79)	2 15/16 (75)
FLR30	3 (76)	6 1/2 (165)	7 9/16 (192)	12 15/16 (329)	14 (356)	2 9/32 (58)	3 3/8 (86)	3 7/16 (87)

- Type AAC Exposed Flange Frame**
- Drywall (ceiling)

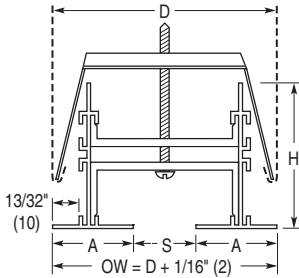

- Type AAC Exposed Flange Frame**
- Drywall (ceiling)

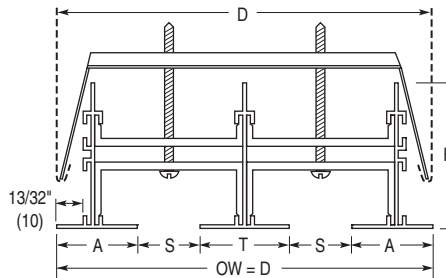

**Dimensional Data - Imperial (Metric) Units**

Model	S Slot Width	D Duct Width		Ceiling Opening Width		A Border Width	H Height	T 2 Slot
		1 Slot	2 Slot	1 Slot	2 Slot			
FLR10	1 (25)	3 1/2 (89)	6 (152)	3 (76)	5 1/2 (140)	1 9/32 (33)	2 3/8 (60)	1 7/16 (37)
FLR15	1 1/2 (38)	4 1/2 (114)	8 (203)	4 (102)	7 1/2 (191)	1 17/32 (39)	2 5/8 (67)	1 15/16 (49)
FLR20	2 (51)	5 1/2 (140)	10 (254)	5 (127)	9 1/2 (241)	1 25/32 (45)	2 7/8 (73)	2 7/16 (62)
FLR25	2 1/2 (64)	6 1/2 (165)	12 (305)	6 (152)	11 1/2 (292)	2 1/32 (52)	3 1/8 (79)	2 15/16 (75)
FLR30	3 (76)	7 1/2 (191)	14 (356)	7 (178)	13 1/2 (343)	2 9/32 (58)	3 3/8 (86)	3 7/16 (87)

**Notes:**

- Material: Heavy duty extruded aluminum frame and spacers.
- Maximum section length is 72" (1823) by default. 96" (2438) and 120" (3048) are available as options. Lengths longer than the maximum section length are furnished in multiple sections with alignment strips, the number and size determined by the factory.
- AW Appliance White finish with black interior surfaces is standard on frame/borders AA and AAC. Optional finishes are available.
- Frame/Border Type AA is supplied w/integral hanger brackets on 24" (610) centers. Frame/Border Type AAC is supplied with concealed mounting brackets and levelling screws on 24" (610) centers. See separate submittal for optional mounting hardware and accessories.

**Option:**

- SP Special Finish \_\_\_\_\_.

**Overall Length & End Cap Position**

	E	L
<input type="checkbox"/> MM	D - 1/4 (6)	D + 9/16 (14)
<input type="checkbox"/> MO	D - 1/8 (3)	D + 9/32 (7)
<input type="checkbox"/> MC	D - 1/16 (2)	D + 11/32 (9)
<input type="checkbox"/> OO	D	D
<input type="checkbox"/> OC	D - 1/16 (2)	D - 1/16 (2)
<input type="checkbox"/> CC	D - 1/8 (3)	D - 1/8 (3)
<input type="checkbox"/> FF	D - 1/4 (6)	D + 1 5/8 (41)
<input type="checkbox"/> FO	D - 1/8 (3)	D + 13/16 (21)
<input type="checkbox"/> FC	D - 1/16 (2)	D + 7/8 (22)

**End Condition**

- M Mitered End Border**

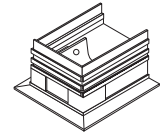
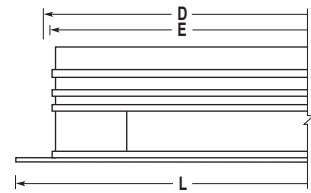

- F Flanged End Cap**  
Type AA Border Only

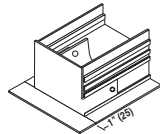
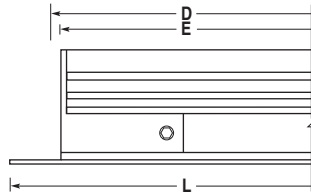

- O Open End**

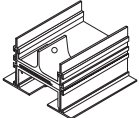
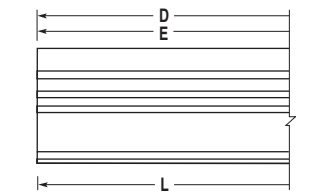

- C Flat End Cap**

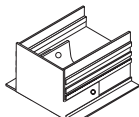
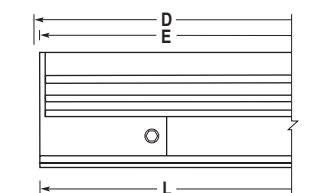

Dimensions are in inches (mm).

**SCHEDULE TYPE**

**PROJECT**

**ENGINEER**

**CONTRACTOR**

**DATE**

**B SERIES**

**SUPERSEDES**

**DRAWING NO.**

3 - 3 - 22

FL

2 - 25 - 21

FLR-1



**FLOWLINE™ LINEAR SLOT DIFFUSERS**  
 ARCHITECTURAL • ALUMINUM  
 RETURN (NO PATTERN CONTROLLERS)  
 MODEL SERIES: FLR TYPES CC, CCA, CCC & CCCA

**CONCEALED SURFACE MOUNT APPLICATION • DRYWALL (CEILING/WALL) TAPE & SPACKLE**

**One Slot**

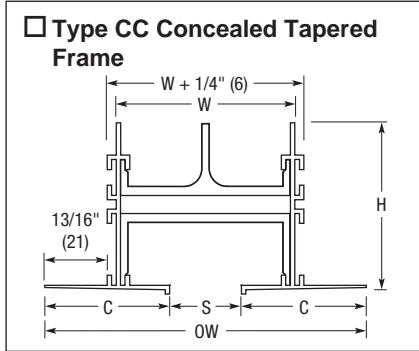

**Two Slot**

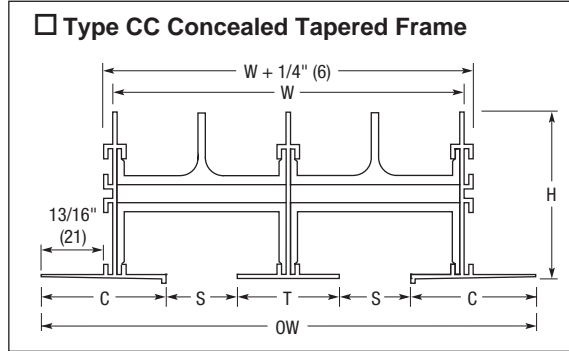

**End Condition**

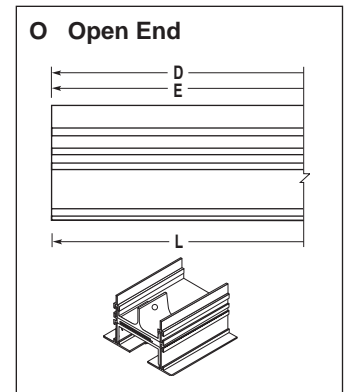
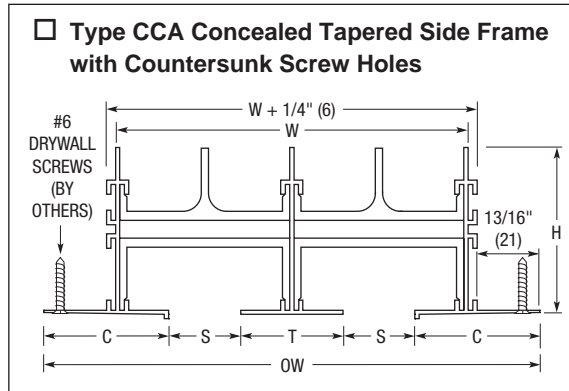
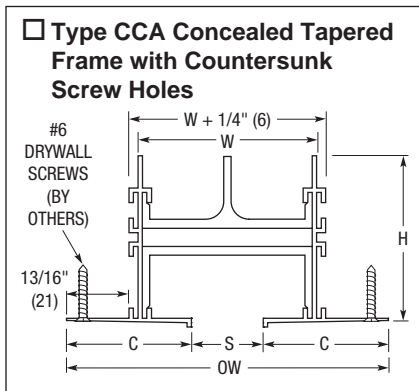
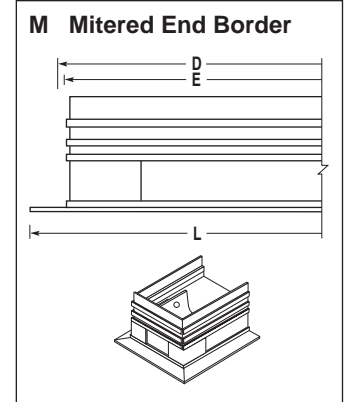

**Dimensional Data - Imperial (Metric) Units**

Model	S Slot Width	1 Slot		2 Slot		C Border Width	H Height	T 2 Slot
		W	OW	W	OW			
FLR10	1 (25)	2 1/2 (64)	4 3/8 (111)	4 15/16 (125)	6 13/16 (173)	1 11/16 (43)	2 3/8 (60)	1 7/16 (37)
FLR15	1 1/2 (38)	3 1/2 (89)	5 3/8 (137)	6 15/16 (176)	8 13/16 (224)	1 15/16 (49)	2 5/8 (67)	1 15/16 (49)
FLR20	2 (51)	4 1/2 (114)	6 3/8 (162)	8 15/16 (227)	10 13/16 (275)	2 3/16 (56)	2 7/8 (73)	2 7/16 (62)
FLR25	2 1/2 (64)	5 1/2 (140)	7 3/8 (187)	10 15/16 (278)	12 13/16 (325)	2 7/16 (62)	3 1/8 (79)	2 15/16 (75)
FLR30	3 (76)	6 1/2 (165)	8 3/8 (213)	12 15/16 (329)	14 13/16 (376)	2 11/16 (68)	3 3/8 (86)	3 7/16 (87)

**Notes:**

- Material: Heavy duty extruded aluminum frame and spacers.
- Maximum section length is 72" (1823) by default. 96" (2438) and 120" (3048) are available as options. Lengths longer than the maximum section length are furnished in multiple sections with alignment strips, the number and size determined by the factory.
- MI Mill finish is standard on frame/border CC with an AW Appliance White center tee on the 2 slot model. Interior surfaces are black.
- Type CC and CCA have integral hanger brackets on 24" (610) centers. See separate submittal for Type CC optional mounting hardware and accessories.

**Options:**

SP Special Finish \_\_\_\_\_.

**Overall Length and End Cap Position**

	E	L
<input type="checkbox"/> MM	D - 1/4 (6)	D + 1 3/8 (35)
<input type="checkbox"/> MO	D - 1/8 (3)	D + 11/16 (17)
<input type="checkbox"/> MC	D - 1/16 (2)	D + 3/4 (19)
<input type="checkbox"/> OO	D	D
<input type="checkbox"/> OC	D - 1/16 (2)	D - 1/16 (2)
<input type="checkbox"/> CC	D - 1/8 (3)	D - 1/8 (3)

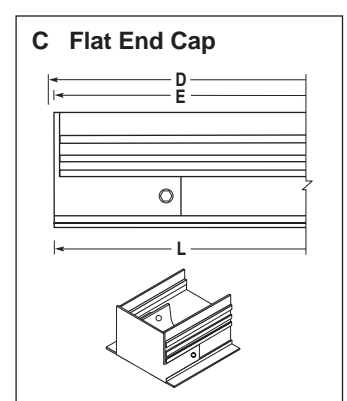

**SCHEDULE TYPE**

**PROJECT**

**ENGINEER**

**CONTRACTOR**

Page 1 of 2  
 Dimensions are in inches (mm).

DATE	B SERIES	SUPERSEDES	DRAWING NO.
12 - 19 - 22	FL	3 - 3 - 22	FLR-2



**One Slot**

**Type CCC Concealed Tapered Frame with Concealed Mounting Brackets**

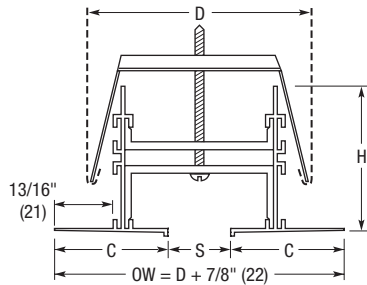

**Two Slot**

**Type CCC Concealed Tapered Side Frame with Concealed Mounting Brackets**

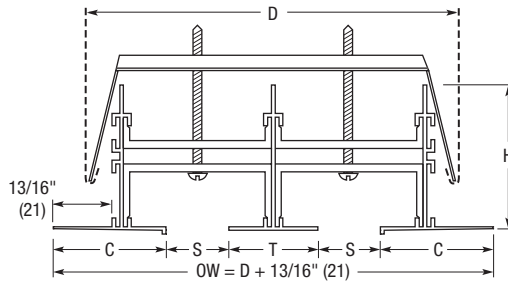

**End Condition**

**M Mitered End Border**

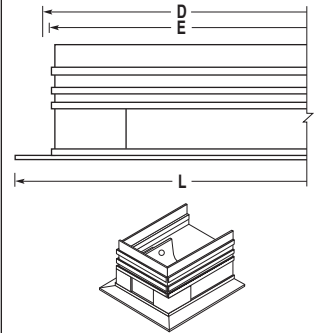

**Type CCCA Concealed Tapered Frame with Concealed Mounting Brackets & Countersunk Screw Holes**

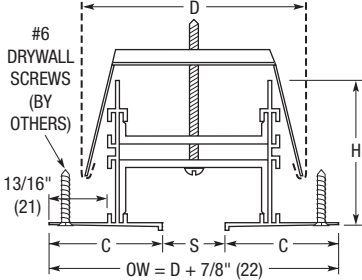

**Type CCCA Concealed Tapered Side Frame with Concealed Mounting Brackets & Countersunk Screw Holes**

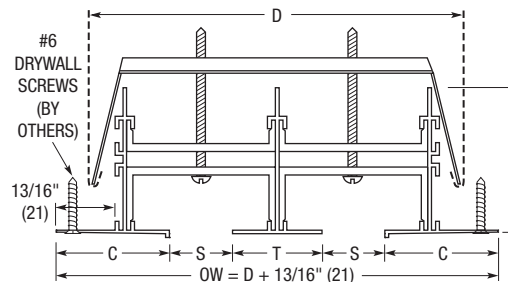

**O Open End**

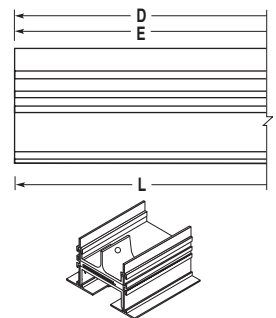

**Dimensional Data - Imperial (Metric) Units**

Model	S Slot Width	D Duct Width		C Border Width	H Height	T 2 Slot	Ceiling Opening Width	
		1 Slot	2 Slot				1 Slot	2 Slot
FLR10	1 (25)	3 1/2 (89)	6 (152)	1 11/16 (43)	2 3/8 (60)	1 7/16 (37)	3 (76)	5 1/2 (140)
FLR15	1 1/2 (38)	4 1/2 (114)	8 (203)	1 15/16 (49)	2 5/8 (67)	1 15/16 (49)	4 (102)	7 1/2 (191)
FLR20	2 (51)	5 1/2 (140)	10 (254)	2 3/16 (56)	2 7/8 (73)	2 7/16 (62)	5 (127)	9 1/2 (241)
FLR25	2 1/2 (64)	6 1/2 (165)	12 (305)	2 7/16 (62)	3 1/8 (79)	2 15/16 (75)	6 (152)	11 1/2 (292)
FLR30	3 (76)	7 1/2 (191)	14 (356)	2 11/16 (68)	3 3/8 (86)	3 7/16 (87)	7 (178)	13 1/2 (343)

**C Flat End Cap**

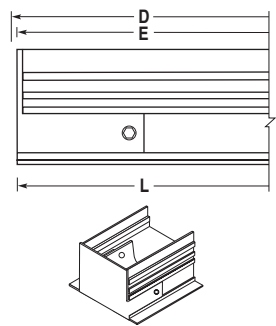

**Notes:**

- Material: Heavy duty extruded aluminum frame and spacers.
- Maximum section length is 72" (1823) by default. 96" (2438) and 120" (3048) are available as options. Lengths longer than the maximum section length are furnished in multiple sections with alignment strips, the number and size determined by the factory.
- MI Mill finish is standard on frame/borders CCC and CCCA with an AW Appliance White center tee on the 2 slot model. Interior surfaces are black.
- Types CCC and CCCA are supplied with concealed mounting brackets and leveling screws on 24" (610) centers. See separate submittal for accessories.

**Overall Length and End Cap Position**

	E	L
<input type="checkbox"/> MM	D - 1/4 (6)	D + 1 3/8 (35)
<input type="checkbox"/> MO	D - 1/8 (3)	D + 11/16 (17)
<input type="checkbox"/> MC	D - 1/16 (2)	D + 3/4 (19)
<input type="checkbox"/> OO	D	D
<input type="checkbox"/> OC	D - 1/16 (2)	D - 1/16 (2)
<input type="checkbox"/> CC	D - 1/8 (3)	D - 1/8 (3)

**Options:**

SP Special Finish \_\_\_\_\_.

<b>SCHEDULE TYPE</b>		Page 2 of 2 Dimensions are in inches (mm).			
<b>PROJECT</b>					
<b>ENGINEER</b>	<b>DATE</b>	<b>B SERIES</b>	<b>SUPERSEDES</b>	<b>DRAWING NO.</b>	
<b>CONTRACTOR</b>	12 - 19 - 22	FL	3 - 3 - 22	FLR-2	



**FLOWLINE™ LINEAR SLOT DIFFUSERS**

ARCHITECTURAL • ALUMINUM

FOR TECHZONE™ TYPE CEILINGS 4" (102) & 6" (152) WIDE

MODEL SERIES FLH-TZ AND FLV-TZ

TYPE LT 15/16" (24) STANDARD T-BAR

**FLH-TZ Horizontal High Throw Pattern Controllers**

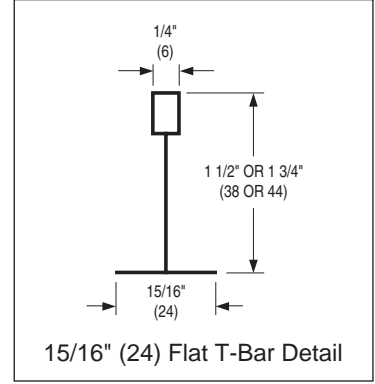
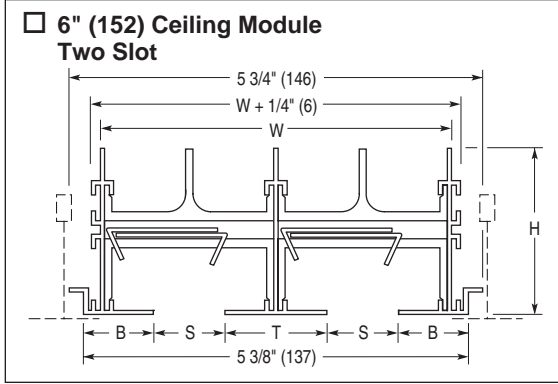
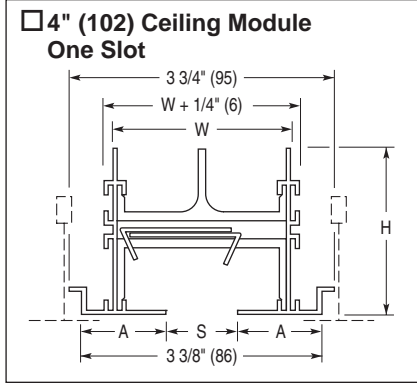

**FLV-TZ Vertical Jet Throw Pattern Controllers**

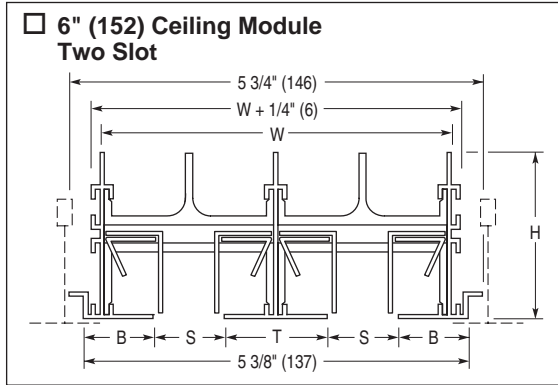
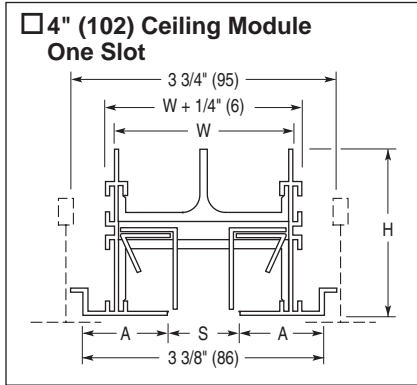

**End Condition**

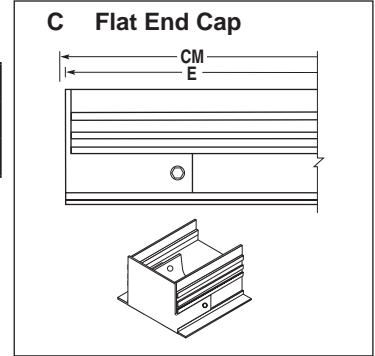
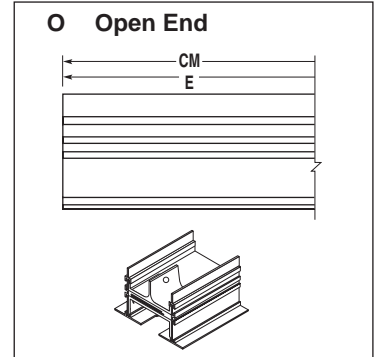

**Dimensional Data - Imperial (Metric) Units**

Model	S Slot Width	1 Slot	2 Slot	Border Width		H Height	T 2 Slot
		W	W	A	B		
FL(H or V)10TZ	1 (25)	2 1/2 (64)	4 15/16 (125)	1 3/16 (30)	31/32 (25)	2 3/8 (60)	1 7/16 (37)

**Notes:**

- Compatible with Armstrong® Techzone™ and USG Logix™ ceiling systems.
- Material: Heavy duty extruded aluminum frame and spacers. Corrosion-resistant steel pattern controllers.
- Available in 24" (610), 30" (762), 36" (914), 48" (1219), 60" (1524) and 72" (1829) standard module lengths. Ends are finished with Type CC flat end caps. Also available in multiple section assemblies with alignment pins for continuous run applications. Maximum section length is 72" (1823) by default. 96" (2438) and 120" (3048) are available as options. Lengths longer than the maximum section length are furnished in multiple sections.
- Adjustable pattern controllers are on max. 24" (610) centers.
- This model is compatible with standard 15/16" (24) flat T-Bar. The Flowline® diffuser lays flush on the T-Bars.
- Integral hanger brackets on 24" (610) centers. See separate submittal for optional mounting hardware and accessories.

**Options:**

- FLP Factory Supplied Plenum (see separate submittal)
- SP Special Finish \_\_\_\_\_.

End Condition	Face Length E
CC	Ceiling Module – 1/4" (6)
OC	Ceiling Module – 1/8" (3)
OO	Ceiling Module

CM = Ceiling Module  
E = Overall length

<b>SCHEDULE TYPE:</b>	
<b>PROJECT:</b>	
<b>ENGINEER:</b>	
<b>CONTRACTOR:</b>	

Dimensions are in inches (mm).

DATE	B SERIES	SUPERSEDES	DRAWING NO.
3 - 3 - 22	FL	10 - 9 - 14R	FL-TZ-1



**FLOWLINE™ LINEAR SLOT DIFFUSERS**  
 ARCHITECTURAL • ALUMINUM  
 FOR TECHZONE™ TYPE CEILINGS 4" (102) & 6" (152) WIDE  
 MODEL SERIES FLH-TZ AND FLV-TZ  
 TYPE NT 9/16" (14) NARROW T-BAR

**FLH-TZ Horizontal High Throw Pattern Controllers**

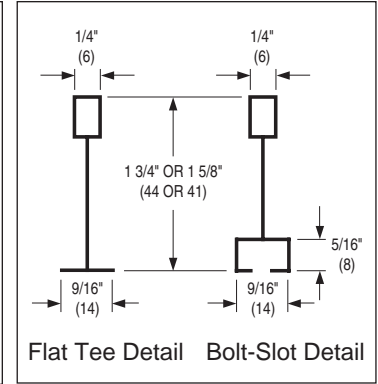
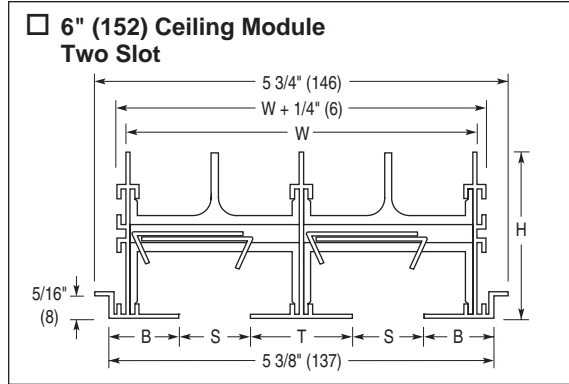
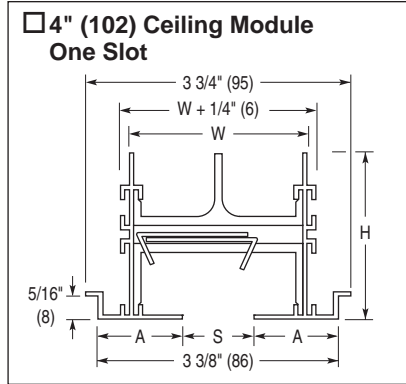

**FLV-TZ Vertical Jet Throw Pattern Controllers**

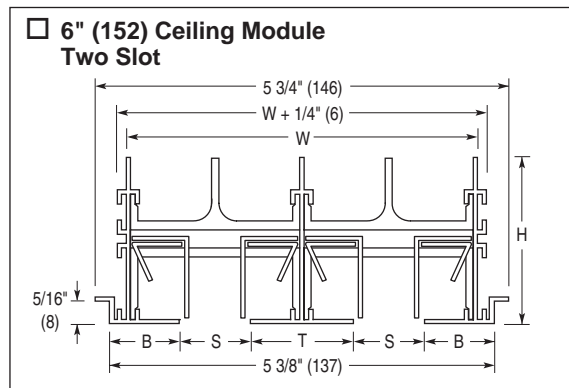
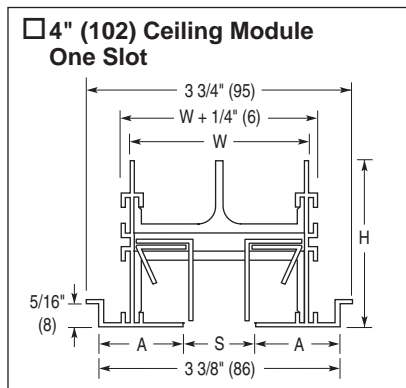

**End Condition**

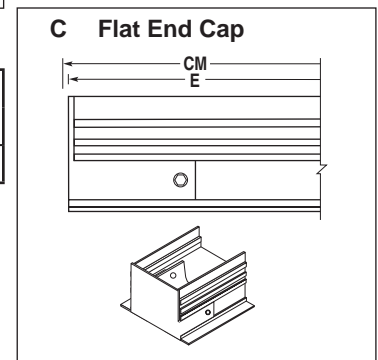
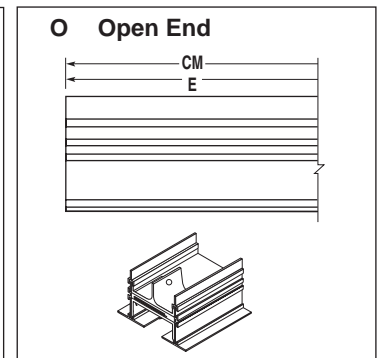

**Dimensional Data - Imperial (Metric) Units**

Model	S Slot Width	1 Slot	2 Slot	Border Width		H Height	T 2 Slot
		W	W	A	B		
FL(H or V)10TZ	1 (25)	2 1/2 (64)	4 15/16 (125)	1 3/16 (30)	31/32 (25)	2 3/8 (60)	1 7/16 (37)

**NOTES:**

- Compatible with Armstrong® Techzone™ and USG Logix™ ceiling systems.
- Material: Heavy duty extruded aluminum frame and spacers. Corrosion-resistant steel pattern controllers.
- Available in 24" (610), 30" (762), 36" (914), 48" (1219), 60" (1524) and 72" (1829) standard module lengths. Ends are finished with Type CC flat end caps. Also available in multiple section assemblies with alignment pins for continuous run applications. Maximum section length is 72" (1823) by default. 96" (2438) and 120" (3048) are available as options. Lengths longer than the maximum section length are furnished in multiple sections.
- Adjustable pattern controllers are on max. 24" (610) centers.
- This model accommodates both 9/16" (14) flat tees to provide a tegular appearance and 9/16" (14) Bolt-Slot (Fineline® Type) regressed tees for a flush appearance with a tegular ceiling tile.
- Integral hanger brackets on 24" (610) centers. See separate submittal for optional mounting hardware and accessories.

**Options:**

- FLP Factory Supplied Plenum (see separate submittal)
- SP Special Finish \_\_\_\_\_.

End Condition	Face Length E
CC	Ceiling Module - 5/8" (16)
OC	Ceiling Module - 5/16" (8)
OO	Ceiling Module

CM = Ceiling Module  
 E = Overall length

<b>SCHEDULE TYPE:</b>		Dimensions are in inches (mm).			
<b>PROJECT:</b>					
<b>ENGINEER:</b>	<b>DATE</b>	<b>B SERIES</b>	<b>SUPERSEDES</b>	<b>DRAWING NO.</b>	
<b>CONTRACTOR:</b>	3 - 3 - 22	FL	10 - 9 - 14R	FL-TZ-2	



**FLOWLINE™ LINEAR SLOT DIFFUSERS**  
**ARCHITECTURAL • ALUMINUM**  
**VERTICAL JET THROW PATTERN CONTROLLERS**  
**MODEL SERIES: FLV TYPES AA & AAC**

**One Slot**

- Type AA Exposed Flange Frame**  
 • Drywall (ceiling, wall), T-bar

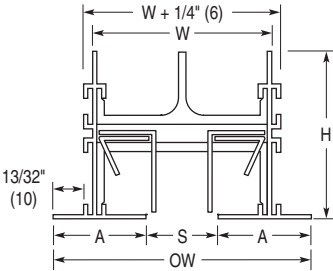

**Two Slot**

- Type AA Exposed Flange Frame**  
 • Drywall (ceiling, wall), T-bar

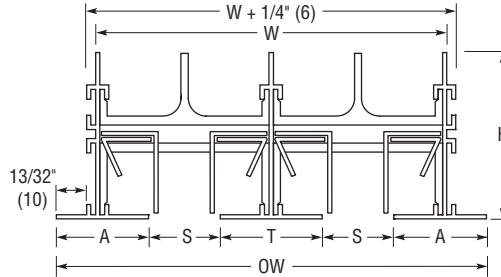

**Dimensional Data - Imperial (Metric) Units**

Model	S Slot Width	1 Slot		2 Slot		A Border Width	H Height	T 2 Slot
		W	OW	W	OW			
FLV10	1 (25)	2 1/2 (64)	3 9/16 (90)	4 15/16 (125)	6 (152)	1 9/32 (33)	2 3/8 (60)	1 7/16 (37)
FLV15	1 1/2 (38)	3 1/2 (89)	4 9/16 (116)	6 15/16 (176)	8 (203)	1 17/32 (39)	2 5/8 (67)	1 15/16 (49)
FLV20	2 (51)	4 1/2 (114)	5 9/16 (141)	8 15/16 (227)	10 (254)	1 25/32 (45)	2 7/8 (73)	2 7/16 (62)
FLV25	2 1/2 (64)	5 1/2 (140)	6 9/16 (167)	10 15/16 (278)	12 (305)	2 1/32 (52)	3 1/8 (79)	2 15/16 (75)
FLV30	3 (76)	6 1/2 (165)	7 9/16 (192)	12 15/16 (329)	14 (356)	2 9/32 (58)	3 3/8 (86)	3 7/16 (87)

- Type AAC Exposed Flange Frame**  
 • Drywall (ceiling)

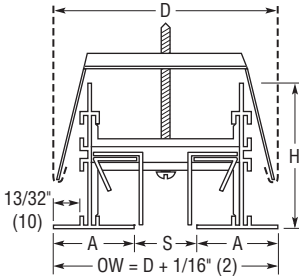

- Type AAC Exposed Flange Frame**  
 • Drywall (ceiling)

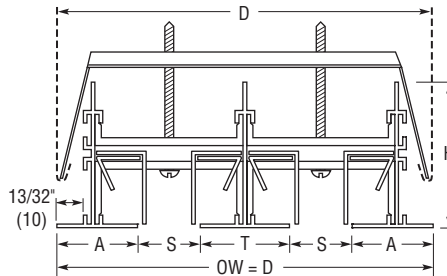

**Dimensional Data - Imperial (Metric) Units**

Model	S Slot Width	D Duct Width		Ceiling Opening Width		A Border Width	H Height	T 2 Slot
		1 Slot	2 Slot	1 Slot	2 Slot			
FLV10	1 (25)	3 1/2 (89)	6 (152)	3 (76)	5 1/2 (140)	1 9/32 (33)	2 3/8 (60)	1 7/16 (37)
FLV15	1 1/2 (38)	4 1/2 (114)	8 (203)	4 (102)	7 1/2 (191)	1 17/32 (39)	2 5/8 (67)	1 15/16 (49)
FLV20	2 (51)	5 1/2 (140)	10 (254)	5 (127)	9 1/2 (241)	1 25/32 (45)	2 7/8 (73)	2 7/16 (62)
FLV25	2 1/2 (64)	6 1/2 (165)	12 (305)	6 (152)	11 1/2 (292)	2 1/32 (52)	3 1/8 (79)	2 15/16 (75)
FLV30	3 (76)	7 1/2 (191)	14 (356)	7 (178)	13 1/2 (343)	2 9/32 (58)	3 3/8 (86)	3 7/16 (87)

**Notes:**

- Material: Heavy duty extruded aluminum frame and spacers. Corrosion resistant steel pattern controllers.
- Maximum section length is 72" (1823) by default. 96" (2438) and 120" (3048) are available as options. Lengths longer than the maximum section length are furnished in multiple sections with alignment strips, the number and size determined by the factory.
- Adjustable pattern controllers are on 24" (610) centers.
- AW Appliance White finish with black pattern controllers and interior surfaces is standard on frame/borders AA and AAC. Optional finishes are available.
- Frame/Border Type AA is supplied with integral hanger brackets on 24" (610) centers. Frame/Border Type AAC is supplied with concealed mounting brackets and levelling screws on 24" (610) centers. See separate submittal for optional mounting hardware and accessories.

**Option:**

- SP Special Finish \_\_\_\_\_.

**Overall Length & End Cap Position**

	E	L
<input type="checkbox"/> MM	D - 1/4 (6)	D + 9/16 (14)
<input type="checkbox"/> MO	D - 1/8 (3)	D + 9/32 (7)
<input type="checkbox"/> MC	D - 1/16 (2)	D + 11/32 (9)
<input type="checkbox"/> OO	D	D
<input type="checkbox"/> OC	D - 1/16 (2)	D - 1/16 (2)
<input type="checkbox"/> CC	D - 1/8 (3)	D - 1/8 (3)
<input type="checkbox"/> FF	D - 1/4 (6)	D + 1 5/8 (41)
<input type="checkbox"/> FO	D - 1/8 (3)	D + 13/16 (21)
<input type="checkbox"/> FC	D - 1/16 (2)	D + 7/8 (22)

**End Condition**

- M Mitered End Border**

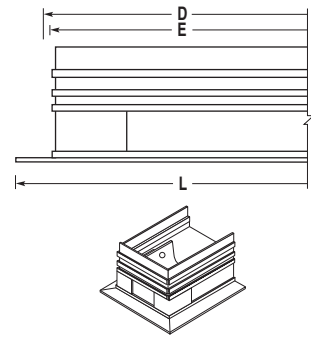

- F Flanged End Cap**  
 Type AA Border Only

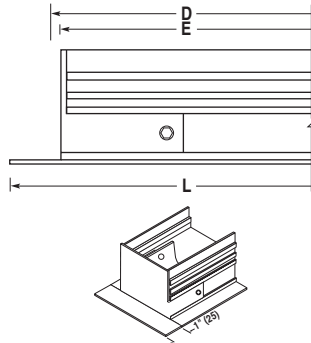

- O Open End**

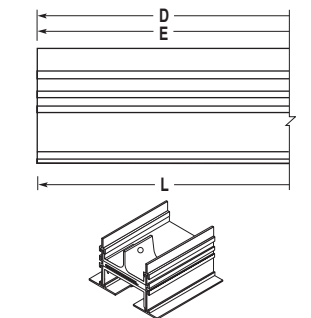

- C Flat End Cap**

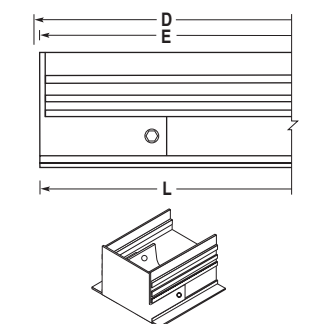

Dimensions are in inches (mm).

**SCHEDULE TYPE**

**PROJECT**

**ENGINEER**

**CONTRACTOR**

**DATE**

**B SERIES**

**SUPERSEDES**

**DRAWING NO.**

3 - 3 - 22

FL

4 - 12 - 16R

FLV-1



**FLOWLINE™ LINEAR SLOT DIFFUSERS**  
**ARCHITECTURAL • ALUMINUM**  
**VERTICAL JET THROW PATTERN CONTROLLERS**  
**MODEL SERIES: FLV TYPES CC, CCA, CCC & CCCA**

**CONCEALED SURFACE MOUNT APPLICATION • DRYWALL (CEILING/WALL) TAPE & SPACKLE**

**One Slot**

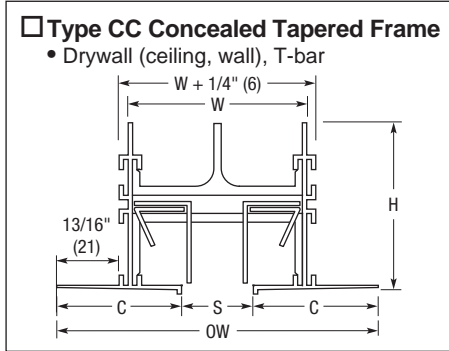

**Two Slot**

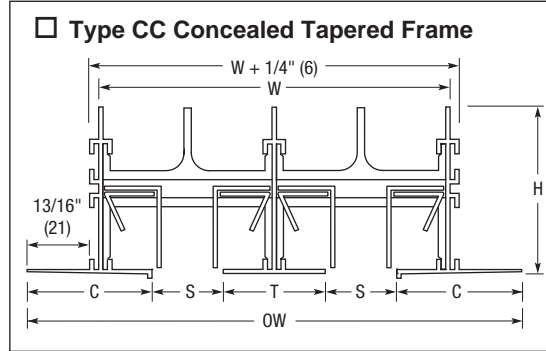

**End Condition**

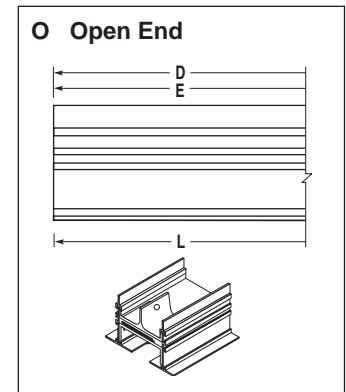
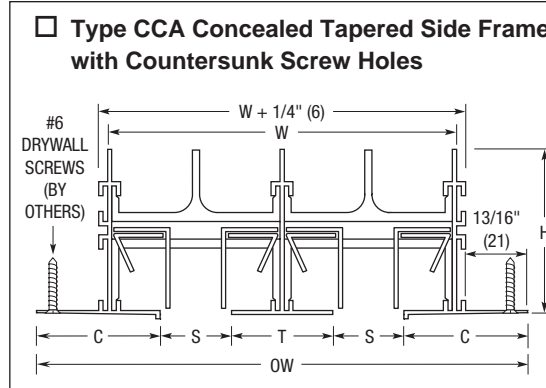
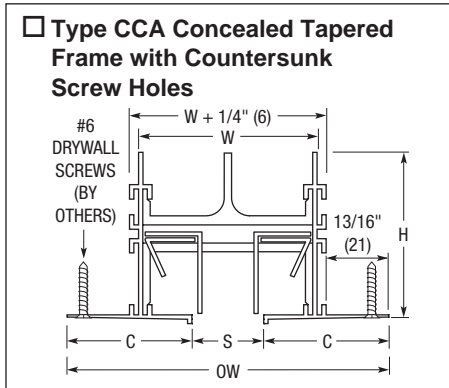
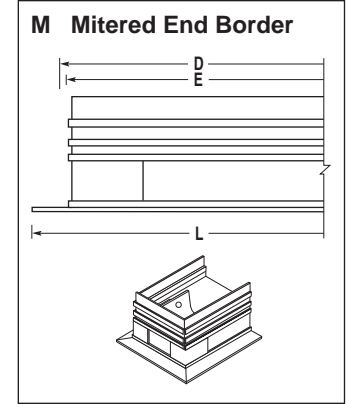

**Dimensional Data - Imperial (Metric) Units**

Model	S Slot Width	1 Slot		2 Slot		C Border Width	H Height	T 2 Slot
		W	OW	W	OW			
FLV10	1 (25)	2 1/2 (64)	4 3/8 (111)	4 15/16 (125)	6 13/16 (173)	1 11/16 (43)	2 3/8 (60)	1 7/16 (37)
FLV15	1 1/2 (38)	3 1/2 (89)	5 3/8 (137)	6 15/16 (176)	8 13/16 (224)	1 15/16 (49)	2 5/8 (67)	1 15/16 (49)
FLV20	2 (51)	4 1/2 (114)	6 3/8 (162)	8 15/16 (227)	10 13/16 (275)	2 3/16 (56)	2 7/8 (73)	2 7/16 (62)
FLV25	2 1/2 (64)	5 1/2 (140)	7 3/8 (187)	10 15/16 (278)	12 13/16 (325)	2 7/16 (62)	3 1/8 (79)	2 15/16 (75)
FLV30	3 (76)	6 1/2 (165)	8 3/8 (213)	12 15/16 (329)	14 13/16 (376)	2 11/16 (68)	3 3/8 (86)	3 7/16 (87)

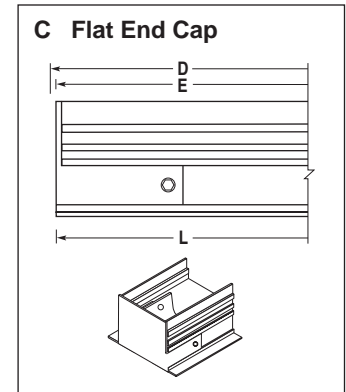

**Notes:**

- Material: Heavy duty extruded aluminum frame and spacers. Corrosion resistant steel pattern controllers.
- Maximum section length is 72" (1823) by default. 96" (2438) and 120" (3048) are available as options. Lengths longer than the maximum section length are furnished in multiple sections with alignment strips, the number and size determined by the factory.
- Adjustable pattern controllers are on 24" (610) centers.
- MI Mill finish is standard on frame/border CC with an AW Appliance White center tee on the 2 slot model. Pattern controllers and interior surfaces are black.
- Type CC and CCA have integral hanger brackets on 24" (610) centers. See separate submittal for Type CC optional mounting hardware and accessories.

**Options:**

SP Special Finish \_\_\_\_\_.

**Overall Length and End Cap Position**

	E	L
<input type="checkbox"/> MM	D - 1/4 (6)	D + 1 3/8 (35)
<input type="checkbox"/> MO	D - 1/8 (3)	D + 11/16 (17)
<input type="checkbox"/> MC	D - 1/16 (2)	D + 3/4 (19)
<input type="checkbox"/> OO	D	D
<input type="checkbox"/> OC	D - 1/16 (2)	D - 1/16 (2)
<input type="checkbox"/> CC	D - 1/8 (3)	D - 1/8 (3)

<b>SCHEDULE TYPE</b>
<b>PROJECT</b>
<b>ENGINEER</b>
<b>CONTRACTOR</b>

Page 1 of 2  
 Dimensions are in inches (mm).

<b>DATE</b>	<b>B SERIES</b>	<b>SUPERSEDES</b>	<b>DRAWING NO.</b>
12 - 19 - 22	FL	3 - 3 - 22	FLV-2A

**One Slot**

**Type CCC Concealed Tapered Frame with Concealed Mounting Brackets**

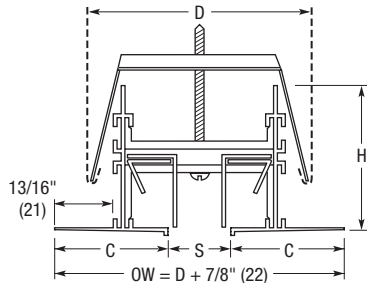

**Two Slot**

**Type CCC Concealed Tapered Side Frame with Concealed Mounting Brackets**

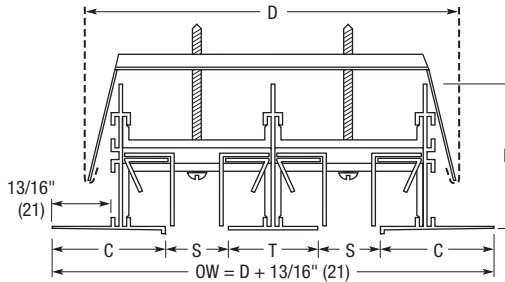

**End Condition**

**M Mitered End Border**

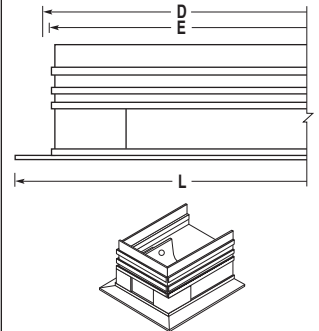

**Type CCCA Concealed Tapered Frame with Concealed Mounting Brackets & Countersunk Screw Holes**

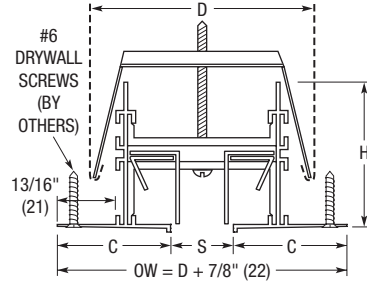

**Type CCCA Concealed Tapered Side Frame with Concealed Mounting Brackets & Countersunk Screw Holes**

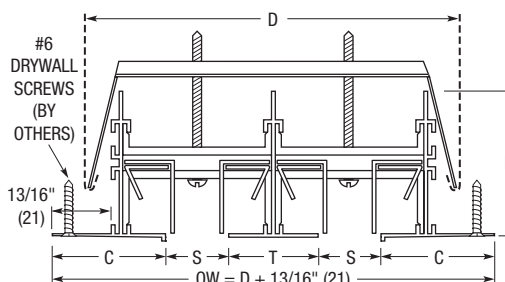

**O Open End**

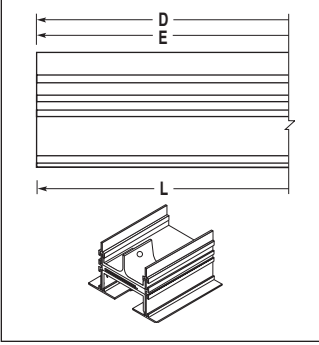

**Dimensional Data - Imperial (Metric) Units**

Model	S Slot Width	D Duct Width		C Border Width	H Height	T 2 Slot	Ceiling Opening Width	
		1 Slot	2 Slot				1 Slot	2 Slot
FLV10	1 (25)	3 1/2 (89)	6 (152)	1 11/16 (43)	2 3/8 (60)	1 7/16 (37)	3 (76)	5 1/2 (140)
FLV15	1 1/2 (38)	4 1/2 (114)	8 (203)	1 15/16 (49)	2 5/8 (67)	1 15/16 (49)	4 (102)	7 1/2 (191)
FLV20	2 (51)	5 1/2 (140)	10 (254)	2 3/16 (56)	2 7/8 (73)	2 7/16 (62)	5 (127)	9 1/2 (241)
FLV25	2 1/2 (64)	6 1/2 (165)	12 (305)	2 7/16 (62)	3 1/8 (79)	2 15/16 (75)	6 (152)	11 1/2 (292)
FLV30	3 (76)	7 1/2 (191)	14 (356)	2 11/16 (68)	3 3/8 (86)	3 7/16 (87)	7 (178)	13 1/2 (343)

**Notes:**

- Material: Heavy duty extruded aluminum frame and spacers. Corrosion resistant steel pattern controllers.
- Maximum section length is 72" (1823) by default. 96" (2438) and 120" (3048) are available as options. Lengths longer than the maximum section length are furnished in multiple sections with alignment strips, the number and size determined by the factory.
- Adjustable pattern controllers are on 24" (610) centers.
- MI Mill finish is standard on frame/borders CCC and CCCA with an AW Appliance White center tee on the 2 slot model. Pattern controllers and interior surfaces are black.
- Types CCC and CCCA are supplied with concealed mounting brackets and leveling screws on 24" (610) centers. See separate submittal for accessories.

**Options:**

SP Special Finish \_\_\_\_\_.

**Overall Length and End Cap Position**

	E	L
<input type="checkbox"/> MM	D - 1/4 (6)	D + 1 3/8 (35)
<input type="checkbox"/> M0	D - 1/8 (3)	D + 11/16 (17)
<input type="checkbox"/> MC	D - 1/16 (2)	D + 3/4 (19)
<input type="checkbox"/> 00	D	D
<input type="checkbox"/> OC	D - 1/16 (2)	D - 1/16 (2)
<input type="checkbox"/> CC	D - 1/8 (3)	D - 1/8 (3)

**C Flat End Cap**

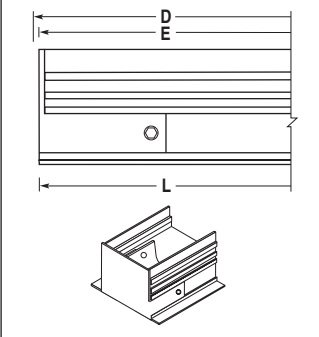

**SCHEDULE TYPE**

**PROJECT**

**ENGINEER**

**CONTRACTOR**

Page 2 of 2  
 Dimensions are in inches (mm).

**DATE**

**B SERIES**

**SUPERSEDES**

**DRAWING NO.**

12 - 19 - 22

FL

3 - 3 - 2

FLV-2A



**FLOWLINE™ LINEAR SLOT DIFFUSERS**  
**ARCHITECTURAL • ALUMINUM**  
**VERTICAL JET THROW PATTERN CONTROLLERS**  
**MODEL SERIES: FLV TYPES GG & AG**

**One Slot**

- Type GG Flangeless Frame**
- Drywall (ceiling, wall)

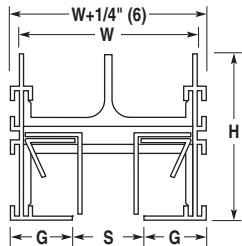

- Type AG Flange / Flangeless Frame**
- Drywall (ceiling, wall)

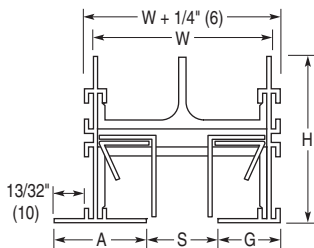

**Two Slot**

- Type GG Flangeless Frame**
- Drywall (ceiling, wall)

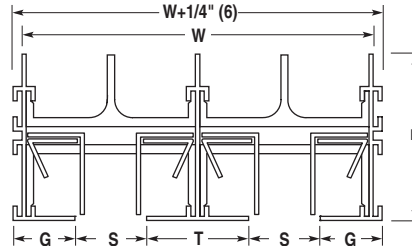

- Type AG Flange / Flangeless Frame**
- Drywall (ceiling, wall)

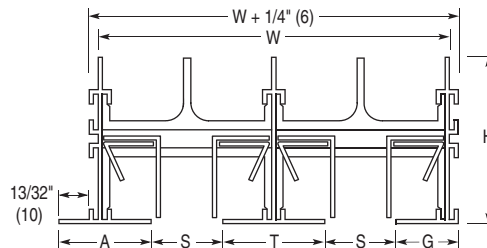

**End Condition**

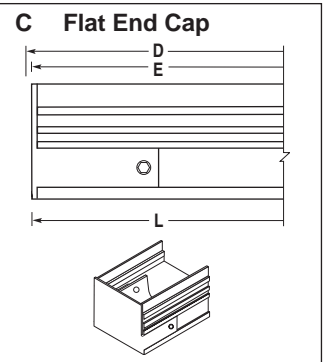
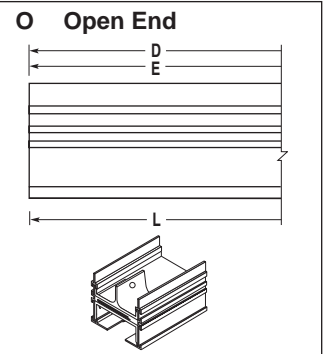
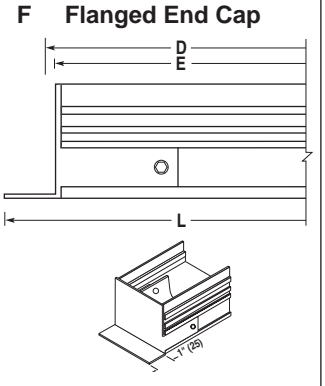

**Dimensional Data - Imperial (Metric) Units**

Model	S Slot Width	1 Slot W	2 Slot W	A Border Width	G Border Width	H Height	T 2 Slot
FLV10	1 (25)	2 1/2 (64)	4 15/16 (125)	1 9/32 (33)	7/8 (22)	2 3/8 (60)	1 7/16 (37)
FLV15	1 1/2 (38)	3 1/2 (89)	6 15/16 (176)	1 17/32 (39)	1 1/8 (29)	2 5/8 (67)	1 15/16 (49)
FLV20	2 (51)	4 1/2 (114)	8 15/16 (227)	1 25/32 (45)	1 3/8 (35)	2 7/8 (73)	2 7/16 (62)
FLV25	2 1/2 (64)	5 1/2 (140)	10 15/16 (278)	2 1/32 (52)	1 5/8 (41)	3 1/8 (79)	2 15/16 (75)
FLV30	3 (76)	6 1/2 (165)	12 15/16 (329)	2 9/32 (58)	1 7/8 (48)	3 3/8 (86)	3 7/16 (87)

**Notes:**

- Material: Heavy duty extruded aluminum frame and spacers. Corrosion resistant steel pattern controllers.
- Maximum section length is 72" (1823) by default. 96" (2438) and 120" (3048) are available as options. Lengths longer than the maximum section length are furnished in multiple sections with alignment strips, the number and size determined by the factory.
- Adjustable pattern controllers are on 24" (610) centers.
- Standard finish is AW Appliance White baked enamel on exposed frames with black pattern controllers and interior surfaces.
- Integral hanger brackets on 24" (610) centers. See separate submittal for optional mounting hardware and accessories.

**Overall Length and End Cap Position**

	E	L
<input type="checkbox"/> 00	D	D
<input type="checkbox"/> 0C	D - 1/16 (2)	D - 1/16 (2)
<input type="checkbox"/> CC	D - 1/8 (3)	D - 1/8 (3)
<input type="checkbox"/> FF	D - 1/4 (6)	D + 1 5/8 (41)
<input type="checkbox"/> FO	D - 1/8 (3)	D + 13/16 (21)
<input type="checkbox"/> FC	D - 1/16 (2)	D + 7/8 (22)

**Options:**

- SP Special Finish \_\_\_\_\_.

**SCHEDULE TYPE**

**PROJECT**

**ENGINEER**

**CONTRACTOR**

Dimensions are in inches (mm).

**DATE**

**B SERIES**

**SUPERSEDES**

**DRAWING NO.**

3 - 3 - 22

FL

2 - 16 - 10R

FLV-3

**Mitered Corners**

- FLMC10 • 1" (25) Slot
- FLMC15 • 1 1/2" (38) Slot
- FLMC20 • 2" (51) Slot
- FLMC25 • 2 1/2" (64) Slot
- FLMC30 • 3" (76) Slot

The standard mitered corners are 90° and 135°. Units are factory welded with precision to match and align with the associated straight leg.

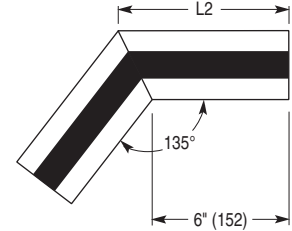
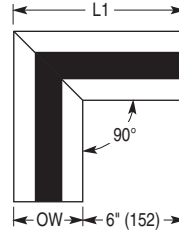

Units are supplied with factory installed blank-offs in the slot (painted black) and are inactive. Other angles are available.

**Special Mitered Corners**

- Other Angle \_\_\_\_\_ .

\*Available from 45 – 179° as SPL. (A detailed sketch is required for co-ordination with installing contractors).

No. of Slots	Slot Width	Border AA			Border CC			Border GG		
		OW	L1	L2	OW	L1	L2	OW	L1	L2
1	1 (25)	3 9/16 (90)	9 9/16 (243)	7 15/32 (190)	4 3/8 (111)	10 3/8 (264)	7 13/16 (198)	2 3/4 (70)	8 11/16 (221)	7 1/8 (181)
	1 1/2 (38)	4 9/16 (116)	10 9/16 (268)	7 7/8 (200)	5 3/8 (137)	11 3/8 (289)	8 1/4 (209)	3 3/4 (95)	9 11/16 (246)	7 17/32 (191)
	2 (51)	5 9/16 (141)	11 9/16 (294)	8 5/16 (211)	6 3/8 (162)	12 3/8 (315)	8 5/8 (219)	4 3/4 (121)	10 11/16 (271)	7 15/16 (202)
	2 1/2 (64)	6 9/16 (167)	12 9/16 (319)	8 23/32 (221)	7 3/8 (187)	13 3/8 (340)	9 1/16 (230)	5 3/4 (146)	11 11/16 (297)	8 11/32 (212)
	3 (76)	7 9/16 (192)	13 9/16 (344)	9 1/8 (232)	8 3/8 (213)	14 3/8 (365)	9 1/2 (241)	6 3/4 (171)	12 11/16 (322)	8 3/4 (222)
2	1 (25)	6 (152)	11 31/32 (304)	8 15/32 (215)	6 13/16 (173)	12 13/16 (325)	8 13/16 (224)	5 3/16 (132)	11 3/32 (282)	8 3/32 (206)
	1 1/2 (38)	8 (203)	13 31/32 (355)	9 5/16 (237)	8 13/16 (224)	14 13/16 (376)	9 5/8 (244)	7 3/16 (183)	13 3/32 (333)	8 29/32 (226)
	2 (51)	10 (254)	15 31/32 (406)	10 1/8 (257)	10 13/16 (275)	16 13/16 (427)	10 1/2 (267)	9 3/16 (233)	15 3/32 (383)	9 3/4 (248)
	2 1/2 (64)	12 (305)	17 31/32 (456)	10 31/32 (279)	12 13/16 (325)	18 13/16 (477)	11 5/16 (287)	11 3/16 (284)	17 3/32 (434)	10 9/16 (268)
	3 (76)	14 (354)	19 31/32 (507)	11 25/32 (299)	14 13/16 (376)	20 13/16 (529)	12 1/8 (308)	13 3/16 (335)	19 3/32 (485)	11 13/32 (290)

**Transitions**

**Type C Cross**

- FLC10 • 1" (25) Slot
- FLC15 • 1 1/2" (38) Slot
- FLC20 • 2" (51) Slot
- FLC25 • 2 1/2" (64) Slot
- FLC30 • 3" (76) Slot

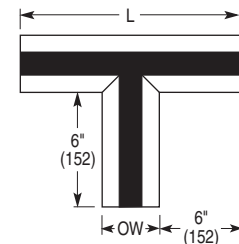
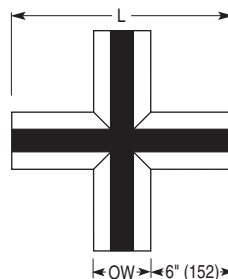

**Type T Tee**

- FLT10 • 1" (25) Slot
- FLT15 • 1 1/2" (38) Slot
- FLT20 • 2" (51) Slot
- FLT25 • 2 1/2" (64) Slot
- FLT30 • 3" (76) Slot

Transitions are inactive. Blank-offs installed at factory. Not available in 2 slot version.

No. of Slots	Slot Width	Border AA		Border CC		Border GG	
		OW	L	OW	L	OW	L
1	1 (25)	3 9/16 (90)	15 9/16 (395)	4 3/8 (111)	16 3/8 (416)	2 3/4 (70)	14 11/16 (373)
	1 1/2 (38)	4 9/16 (116)	16 9/16 (421)	5 3/8 (137)	17 3/8 (442)	3 3/4 (95)	15 11/16 (398)
	2 (51)	5 9/16 (141)	17 9/16 (446)	6 3/8 (162)	18 3/8 (467)	4 3/4 (121)	16 11/16 (424)
	2 1/2 (64)	6 9/16 (167)	18 9/16 (471)	7 3/8 (188)	19 3/8 (493)	5 3/4 (146)	17 11/16 (449)
	3 (76)	7 9/16 (192)	19 9/16 (497)	8 3/8 (213)	20 3/8 (518)	6 3/4 (171)	18 11/16 (475)

**SCHEDULE TYPE**

**PROJECT**

**ENGINEER**

**CONTRACTOR**

**DATE**

**B SERIES**

**SUPERSEDES**

**DRAWING NO.**

1 - 10 - 23

FL

4 - 23 - 21

FLAC-1



**Return Hood / Sight Shield**
**Uninsulated:**

- FLRS10 • 1" (25) Slot
- FLRS15 • 1 1/2" (38) Slot
- FLRS20 • 2" (51) Slot
- FLRS25 • 2 1/2" (64) Slot
- FLRS30 • 3" (76) Slot

**Insulated:**

- FLRSI10 • 1" (25) Slot
- FLRSI15 • 1 1/2" (38) Slot
- FLRSI20 • 2" (51) Slot
- FLRSI25 • 2 1/2" (64) Slot
- FLRSI30 • 3" (76) Slot

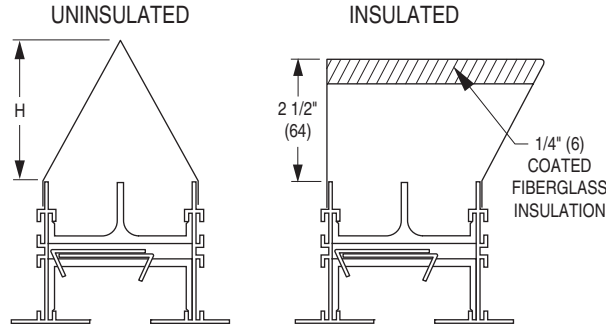

No. of Slots	Slot Width	H Height
1	1 (25)	3 3/8 (86)
	1 1/2 (38)	3 3/8 (86)
	2 (51)	3 3/8 (86)
	2 1/2 (64)	3 3/8 (86)
	3 (76)	3 3/8 (86)
2	1 (25)	2 1/8 (54)
	1 1/2 (38)	3 1/8 (79)
	2 (51)	4 1/8 (105)
	2 1/2 (64)	5 1/8 (130)
	3 (76)	6 1/8 (156)

**Notes:**

1. Material: 51% free area perforated corrosion resistant steel.
2. Available from 12" to 96" (305 to 2438) in 1" (25) increments.
3. Field cut to length if necessary.
4. Finish: Flat Black

SCHEDULE TYPE

PROJECT

ENGINEER

CONTRACTOR

 Page 2 of 4  
 Dimensions are in inches (mm).

DATE

B SERIES

SUPERSEDES

DRAWING NO.

1 - 10 - 23

FL

4 - 23 - 21

FLAC-1



**FLOWLINE™ LINEAR SLOT DIFFUSERS**  
**ARCHITECTURAL • ALUMINUM**  
**OPTIONS AND ACCESSORIES**  
**MODEL SERIES: FLH AND FLV**

**Blank-Offs**

- FLBO10 • 1" (25) Slot
- FLBO15 • 1 1/2" (38) Slot
- FLBO20 • 2" (51) Slot
- FLBO25 • 2 1/2" (64) Slot
- FLBO30 • 3" (76) Slot

Corrosion resistant steel, painted flat black. Fits in neck of diffuser. Provided in 48" (1219) lengths. Field cut to length.

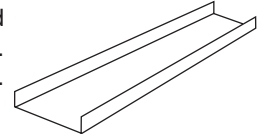

**Mounting Clips**

- HC1 Hard Ceiling Clip 5/8"
- HC5 Hard Ceiling Clip 1/2"

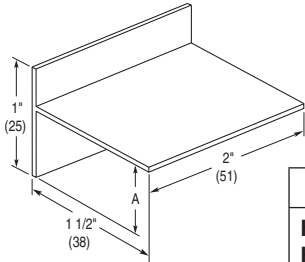

	A Dim.
HC1	5/8" (16)
HC5	1/2" (13)

The HC1 and HC5 Hard Ceiling Clip can be used to mount the FlowLine™ assembly with frame/border types AA, CC or GG, where 5/8" (16) or 1/2" (13) gypsum wallboard (drywall) is used.

**Exposed Flange Frame Type AA**

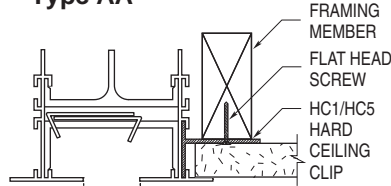

**Concealed Tapered Frame Type CC**

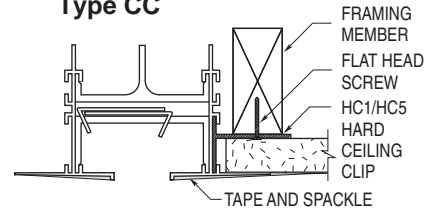

**Flangeless Flush Frame Type GG**

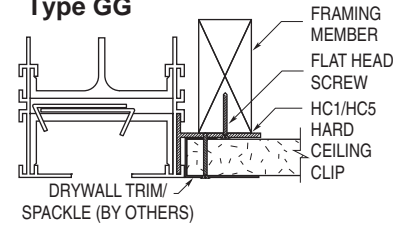

**WC1 Wall Clip**

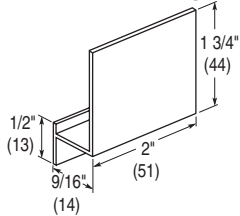

The WC1 WallClip is used to mount the FlowLine™ assembly with frame/border type AA flush to a wall.

**Ceiling / Sidewall Type AA**

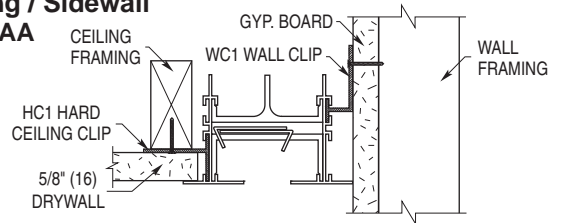

**TC1 T-Bar Clip (Field Formed)**

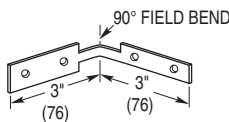

The TC1 T-Bar Clip is used to attach drop tees to the FlowLine™ assembly.

**Ceiling T-Bar Type AA**

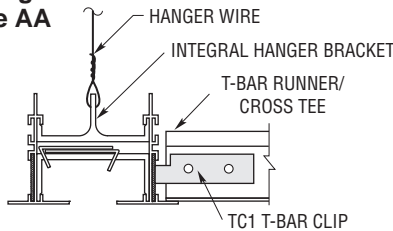

**Ceiling T-Bar (Bolt Slot) Type GG**

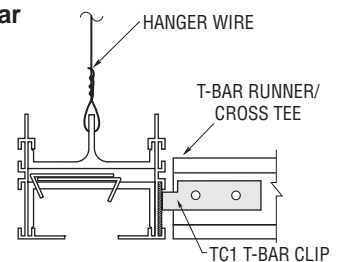

**TC2 Finline T-Bar Clip**

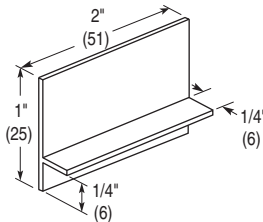

The TC2 Finline T-Bar Clips are used to support and level the Flowline™ assembly in Bolt-Slot (Finline type) suspension systems.

**Flangeless Frame Type GG**

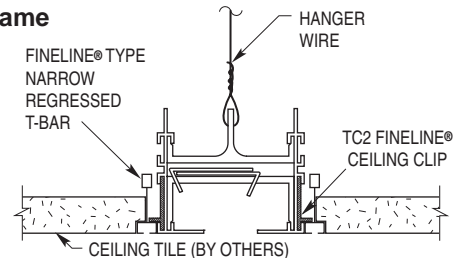

SCHEDULE TYPE

PROJECT

ENGINEER

CONTRACTOR

Page 3 of 4  
 Dimensions are in inches (mm).

DATE

B SERIES

SUPERSEDES

DRAWING NO.

1 - 10 - 23

FL

4 - 23 - 21

FLAC-1

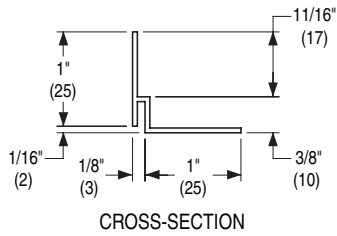
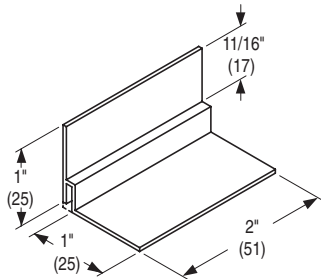
**Mounting Clips**
 **HC2 Hard Ceiling Clip**

The HC2 Hard Ceiling Clip can be used to mount the FlowLine™ assembly with frame/border type **G**, where standard 5/8" (16) gypsum wallboard (drywall) is installed below the frame face.

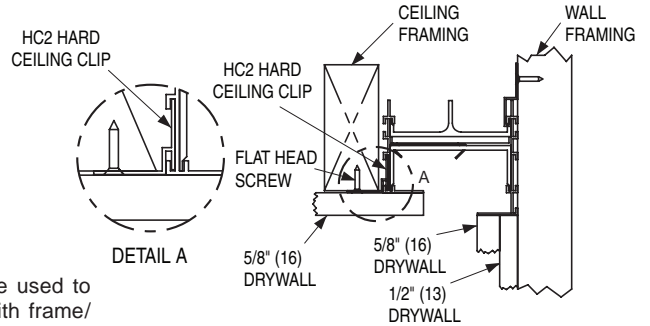
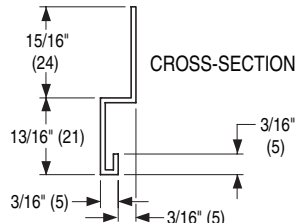
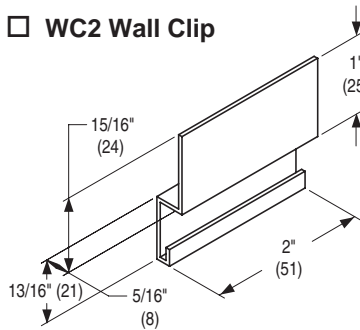
 **Flangeless Concealed Frame Type GJ**
 **WC2 Wall Clip**

The WC2 Wall Clip can be used to mount the FlowLine™ assembly with frame/border types **G** or **J**, flush to a wall.

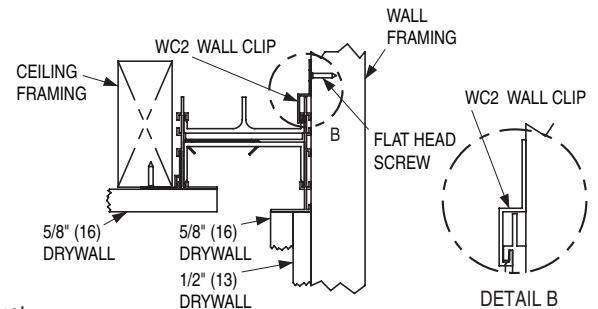
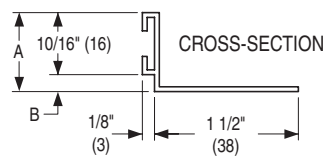
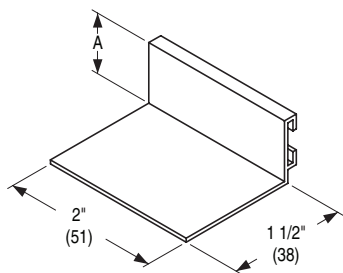
 **Flangeless Concealed Frame Type GJ**
 **HC3 Hard Ceiling Clip for Type K Border**

The HC3 Hard Ceiling Clip can be used to mount the FlowLine™ assembly with frame/border type **K**, where standard 5/8" (16) gypsum wallboard (drywall) is used.

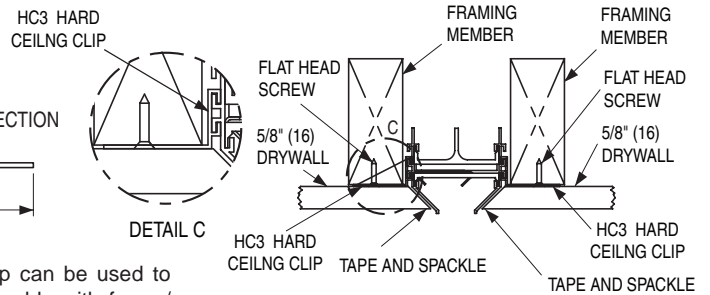
 **Flangeless Concealed Frame Type KK**

Flowline	Part No.	A Dim.	B Dim.
FLH10	HC3-10	13/16 (21)	3/16 (5)
FLH15	HC3-15	1 1/16 (27)	7/16 (11)
FLH20	HC3-20	1 5/16 (33)	11/16 (17)

**SCHEDULE TYPE**
**PROJECT**
**ENGINEER**
**CONTRACTOR**

 Page 4 of 4  
 Dimensions are in inches (mm).

**DATE**
**B SERIES**
**SUPERSEDES**
**DRAWING NO.**

1 - 10 - 23

FL

4 - 23 - 21

FLAC-1



**CURVED FLOWLINE™ LINEAR SLOT DIFFUSERS**  
 ARCHITECTURAL • ALUMINUM  
 CUSTOM LINEAR CURVING – BASIC FLOWLINE® DATA  
 MODEL SERIES: FLH, FLV AND FLR

**Curve Type:**

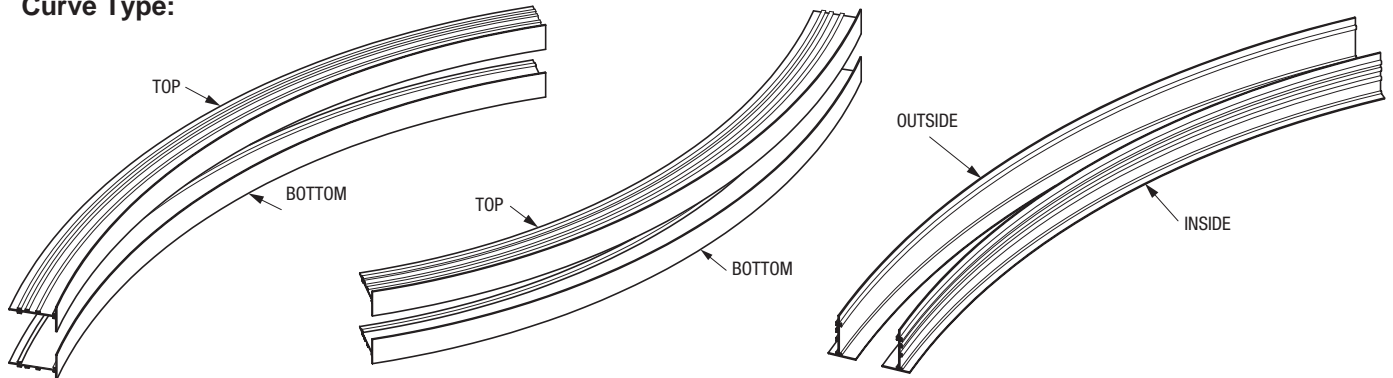

- CAV Concave Face Curve       VEX Convex Face Curve       FLT Flat Face (Web) Curve

**Flowline® Slot Width & Type:**

- FL10, 1" (25) Slot Width       1 Slot  
 FL15, 1 1/2" (38) Slot Width       2 Slot  
 FL20, 2" (51) Slot Width  
 FL25, 2 1/2" (64) Slot Width  
 FL30, 3" (76) Slot Width

**Flowline® Application:**

- FLT Flat Curve, Ceiling  
 CAV Concave Wall / Ceiling  
 VEX Convex Wall / Ceiling

**Pattern Controller Type:**

- FLH Horizontal High Throw  
 FLV Vertical Jet Throw  
 (May not be adjustable).  
 Please note that as radius decreases,  
 pattern controllers are less adjustable.  
 FLR Return (No Pattern Controller)

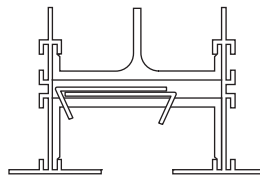

FLH Horizontal High Throw

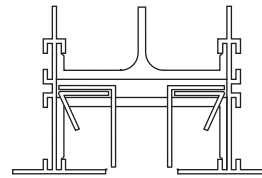

FLV Vertical Jet Throw

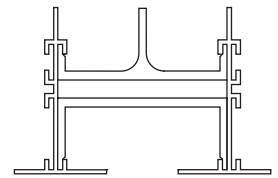

FLR Return

**Frame / Border Type:**

- AA Exposed Flange Frame  
 AAC Exposed Flange Frame with concealed mounting brackets  
 CC Concealed Tapered Frame  
 CCA Concealed Tapered Frame with countersunk screw holes  
 CCC Concealed Tapered Frame with concealed mounting brackets  
 CCCA Concealed Tapered Frame with concealed mounting brackets and countersunk screw holes  
 GG Flangeless Frame

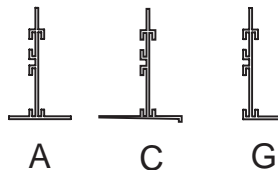

**End Cap Configuration:**

**Frame/Border Types AA, AAC & GG only:**

- FF Flanged Flanged  
 FO Flanged Open  
 FC Flanged Flat Cap

**All Frame/Border Types:**

- OO Open Open  
 OC Open Flat Cap  
 CC Flat Cap Flat Cap

(Mitered end cap not available with curved product).

SCHEDULE TYPE

PROJECT

ENGINEER

CONTRACTOR

Page 1 of 3  
 Dimensions are in inches (mm).

DATE

B SERIES

SUPERSEDES

DRAWING NO.

5 - 20 - 22

FL

11 - 19 - 18

FLCC



**CURVED FLOWLINE™ LINEAR SLOT DIFFUSERS**  
**ARCHITECTURAL • ALUMINUM**  
**CUSTOM LINEAR CURVING – CURVING DATA**  
**MODEL SERIES: FLH, FLV AND FLR**

**Location of Radius Measured Dimension:**

**FLT Flat Face Curve:**

- LRIO Inside edge of opening
- LRCL Centerline of opening

**CAV / VEX Concave/Convex Curve:**

- LRFO Face of opening

**Radius:** \_\_\_\_\_ inches

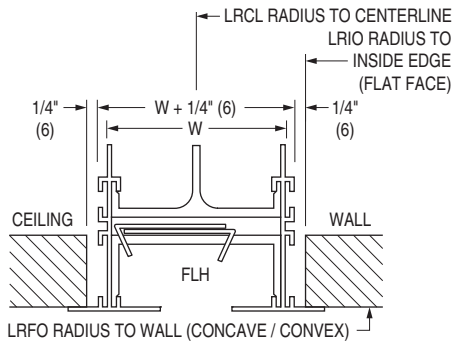

FLT Flat Face Curve, 1 or 2 Slot (1 Slot shown)

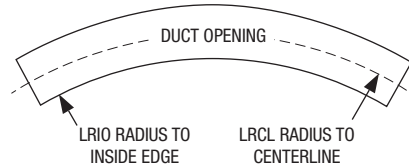

CAV Concave Face Curve

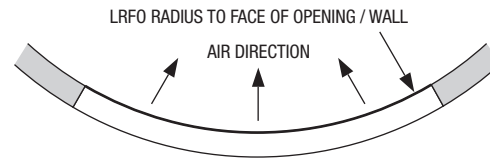

VEX Convex Face Curve

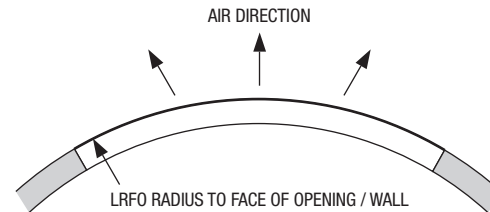

**Length of the Arc, or the Angle:**

- A. ARC Length: \_\_\_\_\_ inches
- B. ANG Angle: \_\_\_\_\_ degrees,
- C. CHR D Chord: \_\_\_\_\_ inches

Length or Angle refers to the slot length. It doesn't include end caps or borders.

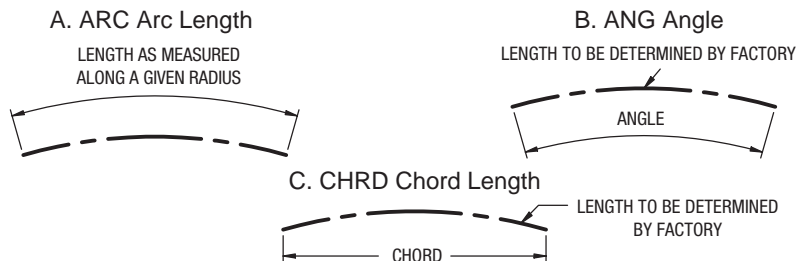

**Minimum Radius:**

Models	Slot Width	Flat Face				Concave & Convex	
		Frame Types AA & GG		Frame Type CC		Frame Types AA, CC & GG	
		1 Slot	2 Slot	1 Slot	2 Slot	1 Slot	2 Slot
FLH10, FLV10, FLR10	1" (25)	30" (762)	30" (762)	40" (1016)	40" (1016)	60" (1524)	60" (1524)
FLH15, FLV15, FLR15	1 1/2" (38)	30" (762)	30" (762)	40" (1016)	40" (1016)	60" (1524)	60" (1524)
FLH20, FLV20, FLR20	2" (51)	60" (1524)	60" (1524)	60" (1524)	60" (1524)	60" (1524)	60" (1524)
FLH25, FLV25, FLR25	2 1/2" (64)	60" (1524)	60" (1524)	60" (1524)	60" (1524)	60" (1524)	60" (1524)
FLH30, FLV30, FLR30	3" (76)	60" (1524)	60" (1524)	60" (1524)	60" (1524)	60" (1524)	60" (1524)

**SCHEDULE TYPE**

**PROJECT**

**ENGINEER**

**CONTRACTOR**

Page 2 of 3  
 Dimensions are in inches (mm).

DATE	B SERIES	SUPERSEDES	DRAWING NO.
5 - 20 - 22	FL	11 - 19 - 18	FLCC



**CURVED FLOWLINE™ LINEAR SLOT DIFFUSERS**  
 ARCHITECTURAL • ALUMINUM  
 CUSTOM LINEAR CURVING – CURVED PLENUMS  
 MODEL SERIES: FLH, FLV AND FLR

**Full Circle:**

Perimeter Length ( $2 \pi r$ ): \_\_\_\_\_ inches

Please specify the radius:

Radius: \_\_\_\_\_ inches

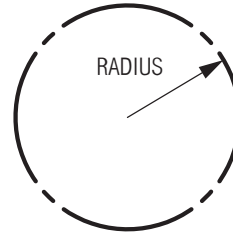

**Two-Radius Ellipse:**

Please specify both radii:

R1: \_\_\_\_\_ inches, R2: \_\_\_\_\_ inches

Please specify the dimensions:

A: \_\_\_\_\_ inches, B: \_\_\_\_\_ inches

C: \_\_\_\_\_ inches, D: \_\_\_\_\_ inches

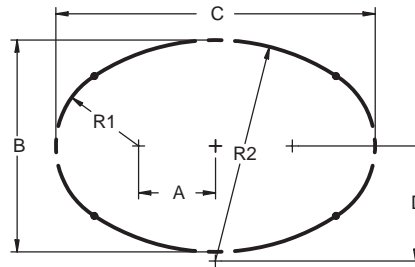

**Serpentine:**

Please specify the following:

R1: \_\_\_\_\_ inches, R2: \_\_\_\_\_ inches

A: \_\_\_\_\_ inches, B: \_\_\_\_\_ inches

L1: \_\_\_\_\_ inches, L2: \_\_\_\_\_ inches

Optional Straight, S: \_\_\_\_\_ inches

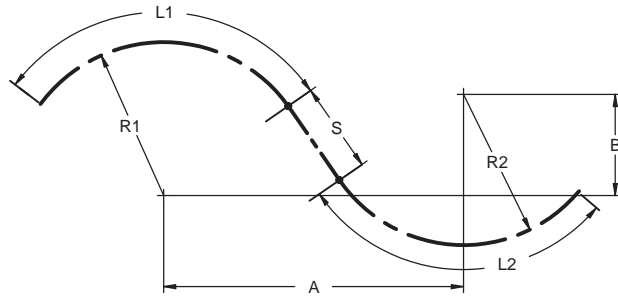

SCHEDULE TYPE

PROJECT

ENGINEER

CONTRACTOR

Page 3 of 3  
 Dimensions are in inches (mm).

DATE

B SERIES

SUPERSEDES

DRAWING NO.

5 - 20 - 22

FL

11 - 19 - 18

FLCC



**CURVED FLOWLINE™ LINEAR SLOT DIFFUSERS**  
 ARCHITECTURAL • ALUMINUM  
 CUSTOM LINEAR CURVING – CURVED PLENUMS  
 MODEL SERIES: FLP

**Type of Plenum Required:**

- A. VEX Convex Face Curve
- B. CAV Concave Face Curve
- C. FLT / IC Flat Face Curve, Inlet on Inside Curve
- D. FLT / OC Flat Face Curve, Inlet on Outside Curve
- E. No Plenum is required (or by others)

**Plenum Attachment Method:**

- A. Type C Hemmed Leg for Concealed Mounting Brackets.  
For use with Frame / Border Types AAC, CCC and CCCA.
  - B. Straight Leg for Direct Attachment to Curved Flowline®.  
For use with Frame / Border Types AA, CC, CCA and GG.
- See catalog page and submittal drawing FLP-1 for description.

**Inlet Size:**

- |  |                                    |
|--|------------------------------------|
| <b>1 Slot</b>                          | <b>2 Slot</b>                      |
| <input type="checkbox"/> 6" Round      | <input type="checkbox"/> 6" Round  |
| <input type="checkbox"/> 8" Round      | <input type="checkbox"/> 8" Round  |
| <input type="checkbox"/> 10" Flat Oval | <input type="checkbox"/> 10" Round |
| <input type="checkbox"/> 12" Flat Oval | <input type="checkbox"/> 12" Round |
| <input type="checkbox"/> 14" Flat Oval | <input type="checkbox"/> 14" Round |

**Notes:**

- All curved Flowline® and curved plenums are custom engineered products. Information supplied on this submittal form is used to prepare fabrication drawings. These drawings require written customer approval prior to their release for production.
- Maximum single section curved length is 120" (3048). Longer lengths are furnished in multiple sections with alignment strips, the number and size determined by factory.
- Adjustable pattern controllers may be on less than 24" (610) centers, as required by the radius, determined by factory.

**Curved Plenum Minimum Radius:**

Model	Flat Face		Concave & Convex	
	1 Slot	2 Slot	1 Slot	2 Slot
FLP (I) 10	30" (762)	30" (762)		
FLP (I) 15	30" (762)	30" (762)		
FLP (I) 20	60" (1524)	60" (1524)	60" (1524)	60" (1524)
FLP (I) 25	60" (1524)	60" (1524)		
FLP (I) 30	60" (1524)	60" (1524)		

**Curved Plenums**

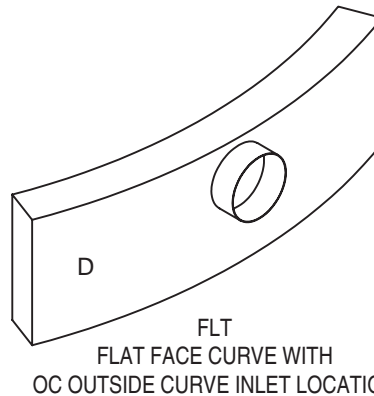
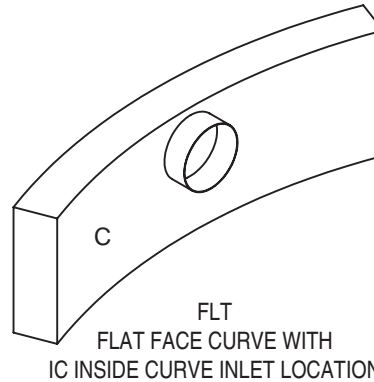
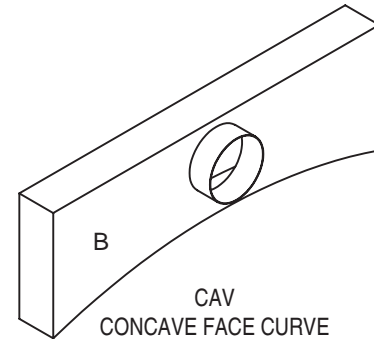
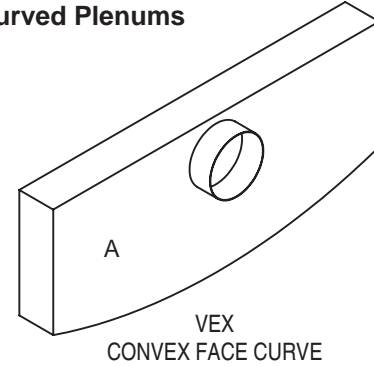

**SCHEDULE TYPE**

**PROJECT**

**ENGINEER**

**CONTRACTOR**

Dimensions are in inches (mm).

**DATE**

**B SERIES**

**SUPERSEDES**

**DRAWING NO.**

1 - 30 - 20

FL

11 - 12 - 18

FLPC



**FLOWLINE™ LINEAR SLOT DIFFUSERS**  
**ACCESSORIES**  
**SUPPLY AIR ENGINEERED PLENUMS**  
**MODEL SERIES: FLP LOW PROFILE OPTION**

**Uninsulated Models:**

- FLP8 • 1" (25) Slot
- FLP10 • 1" (25) Slot
- FLP15 • 1 1/2" (38) Slot
- FLP20 • 2" (51) Slot
- FLP25 • 2 1/2" (64) Slot
- FLP30 • 3" (76) Slot

**Internally Insulated Models:**

- FLPI8 • 1" (25) Slot
- FLPI10 • 1" (25) Slot
- FLPI15 • 1 1/2" (38) Slot
- FLPI20 • 2" (51) Slot
- FLPI25 • 2 1/2" (64) Slot
- FLPI30 • 3" (76) Slot

Flowline™ Plenum

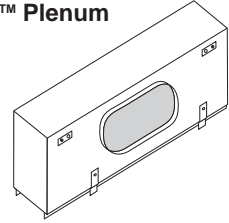

- Straight Leg (Direct Attachment)**  
 For use with Frame / Border Types  
 AA, CA, CC, CCA, CG, GG, GJ,  
 KK, LT, NT

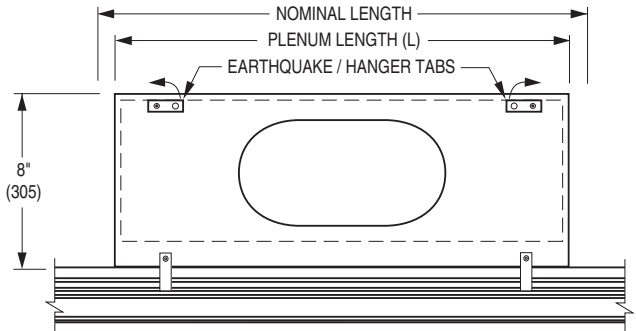
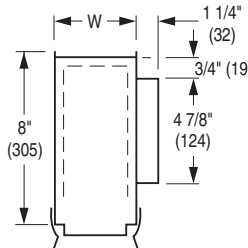

- Hemmed Leg (For concealed mounting bracket)**  
 For use with Frame / Border Types  
 AAC, CCC, CCCA

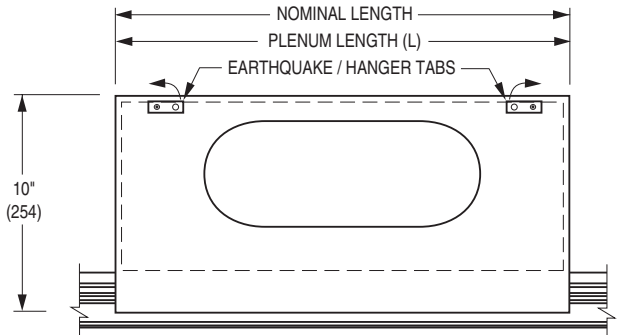
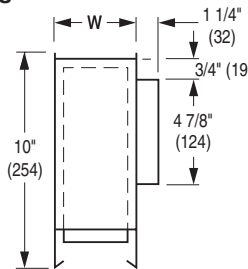

**Dimensional Data**

Nominal Length	Actual Plenum Length (L) for Frame/Border Type		Available Inlet Sizes & Flat Oval Dimension
	AA, CA, CC, CCA, CG, GG, GJ, KK, LT, NT	AAC, CCC, CCCA	
24 (610)	20 3/4 (527)	24 (610)	6 (152) = 6 7/16 x 4 7/8 (164 x 124) 8 (203) = 9 9/16 x 4 7/8 (243 x 124) 10 (254) = 12 3/4 x 4 7/8 (324 x 124) 12 (305) = 15 7/8 x 4 7/8 (403 x 124) 14 (356) = 19 x 4 7/8 (483 x 124)
30 (762)	26 3/4 (679)	30 (762)	
36 (914)	32 3/4 (832)	36 (914)	
48 (1219)	44 3/4 (1137)	48 (1219)	
60 (1524)	56 3/4 (1441)	60 (1524)	
66 (1676)	62 3/4 (1594)	66 (1676)	
72 (1829)	68 3/4 (1746)	72 (1829)	

Plenum Model	Width (W) for Frame/Border Type Noted			
	AA, CA, CC, CCA, CG, GG, GJ, KK, LT, NT		AAC, CCC, CCCA	
	1 Slot	2 Slot	1 Slot	2 Slot
FLP(I)10	2 3/4 (70)	5 3/16 (132)	3 1/2 (89)	5 15/16 (151)
FLP(I)15	3 3/4 (95)	7 3/16 (183)	4 1/2 (114)	7 15/16 (202)
FLP(I)20	4 3/4 (121)	9 3/16 (233)	5 1/2 (140)	9 15/16 (252)
FLP(I)25	5 3/4 (146)	11 3/16 (284)	6 1/2 (165)	11 15/16 (303)
FLP(I)30	6 3/4 (171)	13 3/16 (335)	7 1/2 (191)	13 15/16 (354)

**Notes:**

- Heavy gauge corrosion resistant steel construction.
- Earthquake tabs are standard.
- Straight leg plenums are supplied with spring clips.

**Options:**

- EX External Foil Back Insulation.
- ID ID Inlet damper.
- NI No Inlet.

**SCHEDULE TYPE**

**PROJECT**

**ENGINEER**

**CONTRACTOR**

Dimensions are in inches (mm).

**DATE**

**B SERIES**

**SUPERSEDES**

**DRAWING NO.**

3 - 10 - 23

FL

NEW

FLP-LPP



Nailor offers a selection of standard colors and finishes available on our grilles, registers and diffusers. For painted finishes, our state-of-the-art paint systems provide environmentally friendly finishing solutions with uniform coverage and coating thickness. The result is an exceptionally durable finish that resists scratching, corrosion and general wear. Additional facilities for special requirements, as well as a selection of anodized or brushed finishes, complete our ability to provide unmatched beauty and durability for any application.

**NAILOR POWDER COAT PROPERTIES**

FILM THICKNESS	2.0 to 3.0 mils
HARDNESS	2 H
IMPACT RESISTANCE	Direct: 160 inch - lbs. Reverse 160 inch - lbs.
SALT SPRAY	1000 hours

**ELECTROCOATING PROPERTIES**

FILM THICKNESS	.8 to 1.2 mils
HARDNESS	HB TO H
IMPACT RESISTANCE	80 inch - lbs
SALT SPRAY	100 hours

**POWDER COAT**

Nailor's powder coat is a high-tech thermosetting polyester powder coating with superior physical properties that provide excellent color and gloss retention. The finish offers extreme durability and hardness that resists scratching, chipping and general wear. Surface preparation includes degreasing and a chemical cleaning followed by a clean rinse before a final powder coat finish is applied and baked. The environmentally friendly Nailor powder coat system assures uniform coverage and color consistency resulting in a long lasting superior finish. Colors, including simulated anodizing, which is far more economical than color anodizing, can be selected from Nailor's standard color chart or non-standard colors and can be matched from sample chips provided to Nailor.

**ELECTROCOATING**

E-Coat is an environmentally friendly coating that provides complete coverage and a wide range of performance properties, formulated to meet corrosion, durability and other performance specifications. Electrocoating is a highly automated process in which paint is electrically deposited onto a metal foundation. Film build thickness is uniform and overall application efficiencies are in excess of 90%. Paint is consistent on all part-to-part surfaces, preventing sags, runs or drips. E-Coat offers flexibility, better first yield pass and quicker production times compared to other forms of paint applications. Electrocoating is an excellent solution that offers superior properties and uniform finish.

**CLEAR ANODIZING** (Aluminum products only)

Clear anodizing is a clear oxide coating that exemplifies an aluminum surface's natural oxide coating producing a hard, scratch resistant surface that is resistant to general wear and mild chemicals. The process provides a natural looking, virtually maintenance free finish that will endure for many years.

**COLOR ANODIZING** (Aluminum products only)

Color anodizing is an electrolytic process where, after standard anodizing procedures, colored metallic pigments penetrate the oxide surface pores producing a corrosion resistant, colorfast finish. The process results in a natural metallic appearance that requires little maintenance.

**BRUSHED AND CLEAR COAT**

Available on specific aluminum products (consult applicable product page for availability). Surface is brushed to achieve a scratch finish texture before being degreased and chemically cleaned. A clear lacquer coating is then applied to provide a durable protective finish.

**#4 BRUSHED SATIN POLISHED** (Stainless Steel products only)

Surface is polished to ASTM A480 #4 standard to achieve a bright durable finish that is resistant to mild chemicals and corrosion. A final coating is not required due to the inherent anti-corrosion properties of the stainless steel.

**PRIME COAT**

Prime coat provides a stable base for painting in the field. Surface pretreatment includes degreasing and a chemical cleaning before an alkyd prime coat is applied. After a thorough cleaning for dust, etc. that can contaminate the final finish and cause premature flaking or peeling, finish coat should be field applied as soon as possible.

**PAINT PREPARED ALUMINUM** (Aluminum products only)

Allows for field applied paint. Surface preparation includes degreasing and a chemical cleaning followed by a clean rinse. Finish coat should be field applied as soon as possible.

**MILL FINISH**

Surface is left untreated and requires cleaning, degreasing, etc. in the field before final finish can be applied if required.



**Nailor**<sup>®</sup>  
Industries Inc.

## STANDARD AND OPTIONAL FINISHES FOR GRILLES AND DIFFUSERS

The following standard colors and finishes are available on applicable Nailor air distribution products. Consult individual product pages for availability

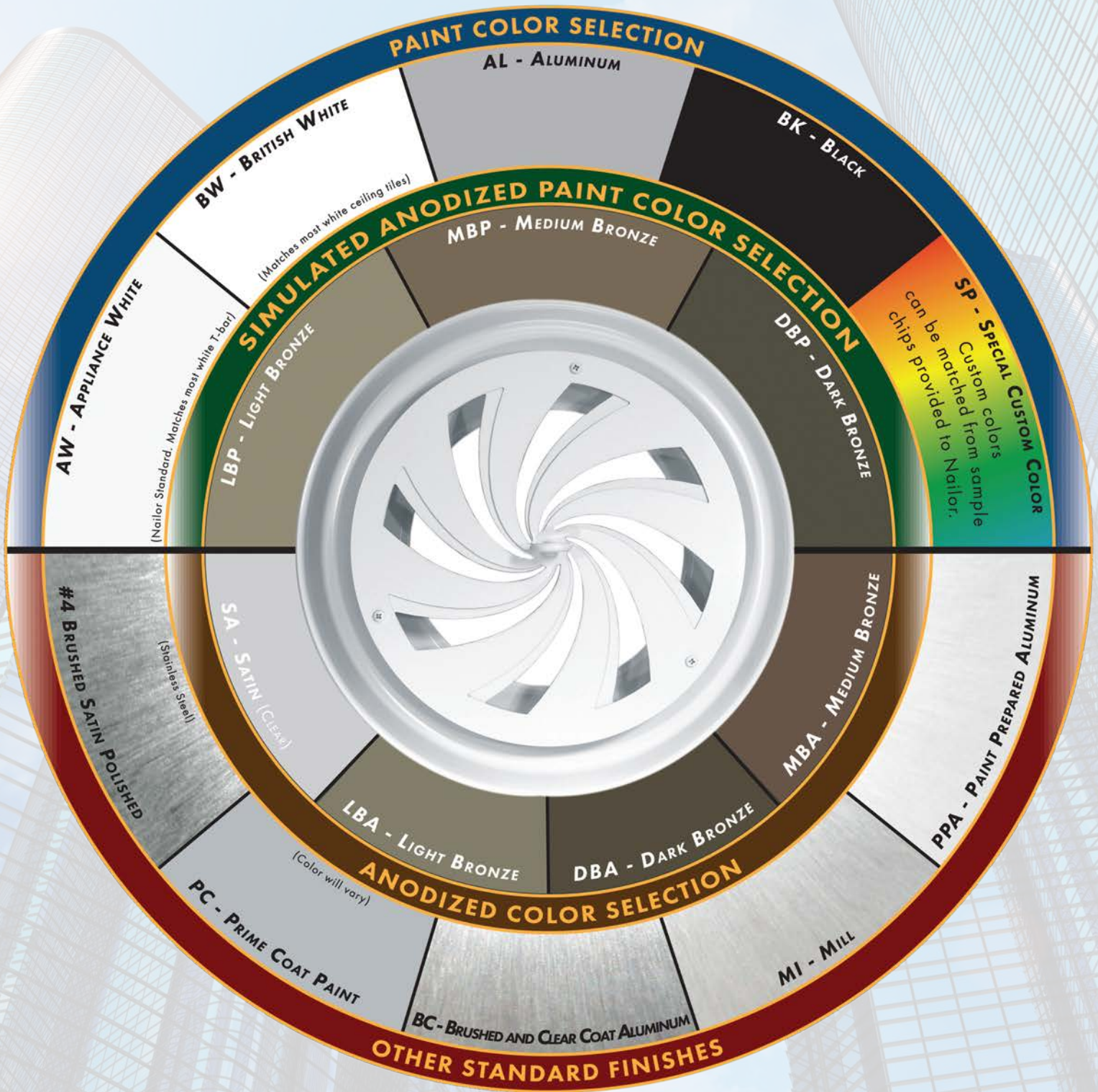

The pictured finishes have been represented as best as possible within printing limitations. However, actual finish may vary. Contact your Nailor representative for a color chip sample on the material specified for a more accurate representation.

**DBK** - Black (for registers ordered with factory mounted dampers) - **BA** - Perforated Diffusers (4300 series only) Appliance White (AW) face with black back pan and pattern controllers.

"Complete Air Control and Distribution Solutions."

WGDSOF2015

[www.nailor.com](http://www.nailor.com)

**PERFORMANCE DATA • HORIZONTAL HIGH THROW SERIES**

**MODELS: FLH / FTH (10 &15) • 1 SLOT WITH NAILOR PLENUM**

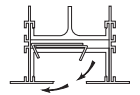

**A**

**FLOWLINE™ LINEAR DIFFUSERS**

<b>1" Slot Width</b>	<b>1 Slot 6" Dia. Inlet</b>	<b>2 Ft.</b>	Airflow, CFM	25	50	75	100	125	150	175
			Total Pressure	.008	.034	.075	.132	.206	.297	.040
			Static Pressure	.007	.030	.065	.115	.180	.260	.350
			Noise Criteria	<15	<15	<15	20	29	36	40
			Throw	1-2-5	3-6-9	5-9-12	7-10-13	8-10-14	9-11-16	10-12-18
		<b>4 Ft.</b>	Airflow, CFM	40	80	120	160	200	240	280
			Total Pressure	.009	.031	.066	.117	.180	.264	.352
			Static Pressure	.006	.020	.042	.075	.115	.170	.225
			Noise Criteria	<15	<15	<15	17	25	32	38
			Throw	1-2-5	3-6-12	5-9-15	8-12-17	10-12-18	12-15-20	13-16-22
		<b>5 Ft.</b>	Airflow, CFM	50	100	150	200	250	300	350
			Total Pressure	.009	.036	.079	.140	.217	.316	.424
			Static Pressure	.005	.020	.042	.075	.115	.170	.225
			Noise Criteria	<15	<15	<15	18	26	33	38
			Throw	1-2-7	3-7-13	8-10-17	10-13-19	12-15-20	14-16-22	15-17-24
<b>1" Slot Width</b>	<b>1 Slot 8" Dia. Inlet</b>	<b>2 Ft.</b>	Airflow, CFM	50	75	100	125	150	175	200
			Total Pressure	.029	.068	.119	.188	.272	.358	.471
			Static Pressure	.028	.065	.114	.180	.260	.342	.450
			Noise Criteria	<15	<15	20	28	35	41	44
			Throw	2-5-9	5-9-11	7-10-14	8-11-15	9-12-18	10-12-19	11-13-20
		<b>4 Ft.</b>	Airflow, CFM	70	110	150	190	230	270	310
			Total Pressure	.016	.040	.075	.120	.176	.242	.319
			Static Pressure	.014	.034	.063	.101	.149	.205	.270
			Noise Criteria	<15	<15	<15	23	30	36	41
			Throw	2-4-10	6-8-14	7-11-17	9-13-19	10-15-22	13-16-24	15-18-26
		<b>5 Ft.</b>	Airflow, CFM	80	130	180	230	280	330	380
			Total Pressure	.007	.025	.056	.093	.142	.206	.283
			Static Pressure	.006	.020	.044	.072	.110	.160	.220
			Noise Criteria	<15	<15	<15	23	29	35	40
			Throw	2-5-11	6-9-15	8-12-18	9-14-20	11-15-22	13-17-24	14-18-26
<b>1.5" Slot Width</b>	<b>1 Slot 6" Dia. Inlet</b>	<b>2 Ft.</b>	Airflow, CFM	30	60	90	120	150	180	210
			Total Pressure	.002	.038	.088	.148	.246	.367	.471
			Static Pressure	.001	.032	.075	.125	.210	.315	.400
			Noise Criteria	<15	<15	<15	22	31	39	44
			Throw	1-4-7	4-7-11	6-9-13	8-10-15	10-13-17	11-14-19	12-15-20
		<b>4 Ft.</b>	Airflow, CFM	70	110	150	190	230	270	310
			Total Pressure	.021	.045	.089	.148	.206	.288	.376
			Static Pressure	.013	.025	.052	.089	.120	.170	.220
			Noise Criteria	<15	<15	<15	20	24	30	36
			Throw	2-5-11	5-8-15	8-12-17	10-13-19	12-15-20	13-16-21	14-17-23
		<b>5 Ft.</b>	Airflow, CFM	85	135	185	235	285	335	385
			Total Pressure	.013	.055	.101	.165	.247	.342	.440
			Static Pressure	.001	.025	.045	.075	.115	.160	.200
			Noise Criteria	<15	<15	<15	20	26	31	37
			Throw	2-5-11	5-19-15	8-13-18	11-15-21	12-17-23	14-18-25	15-20-27
<b>1.5" Slot Width</b>	<b>1 Slot 8" Dia. Inlet</b>	<b>2 Ft.</b>	Airflow, CFM	30	60	90	120	150	180	210
			Total Pressure	.002	.032	.076	.128	.222	.317	.428
			Static Pressure	.001	.030	.072	.120	.210	.300	.405
			Noise Criteria	<15	<15	<15	23	31	40	44
			Throw	1-4-7	4-7-11	7-9-13	8-12-15	10-13-17	11-14-18	12-15-19
		<b>4 Ft.</b>	Airflow, CFM	70	120	170	220	270	320	370
			Total Pressure	.015	.035	.075	.125	.207	.272	.380
			Static Pressure	.012	.027	.060	.100	.170	.220	.310
			Noise Criteria	<15	<15	<15	22	30	36	44
			Throw	2-5-11	6-9-15	9-13-18	12-15-21	14-17-23	15-19-25	16-20-26
		<b>5 Ft.</b>	Airflow, CFM	85	145	205	265	325	385	445
			Total Pressure	.016	.041	.084	.131	.204	.276	.401
			Static Pressure	.012	.03	.062	.095	.150	.200	.300
			Noise Criteria	<15	<15	<15	23	30	36	43
			Throw	2-5-11	6-10-16	9-13-20	12-17-23	15-19-25	16-20-27	17-21-29
<b>1.5" Slot Width</b>	<b>1 Slot 10" Dia. Inlet</b>	<b>2 Ft.</b>	Airflow, CFM	30	60	90	120	150	180	210
			Total Pressure	.002	.027	.065	.109	.189	.269	.364
			Static Pressure	.002	.026	.063	.106	.184	.263	.355
			Noise Criteria	<15	<15	<15	20	28	37	41
			Throw	1-4-7	4-7-11	7-9-13	8-12-15	10-13-17	11-14-18	12-15-19
		<b>4 Ft.</b>	Airflow, CFM	70	120	170	220	270	320	370
			Total Pressure	.013	.030	.064	.106	.176	.231	.323
			Static Pressure	.012	.027	.058	.096	.161	.210	.294
			Noise Criteria	<15	<15	<15	19	27	33	41
			Throw	2-5-11	6-9-15	9-13-18	12-15-21	14-17-23	15-19-25	16-20-26
		<b>5 Ft.</b>	Airflow, CFM	85	145	205	265	325	385	445
			Total Pressure	.014	.035	.071	.111	.173	.235	.341
			Static Pressure	.012	.030	.063	.097	.151	.204	.299
			Noise Criteria	<15	<15	<15	20	27	33	40
			Throw	2-5-11	6-10-16	9-13-20	12-17-23	15-19-25	16-20-27	17-21-29

For performance table notes, see page A37.

**PERFORMANCE DATA • HORIZONTAL HIGH THROW SERIES**

**MODELS: FLH / FTH (20 & 25) • 1 SLOT WITH NAILOR PLENUM**

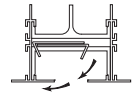

**FLOWLINE™ LINEAR DIFFUSERS**

Slot Width	Inlet Type	Length	Airflow, CFM							
			40	80	120	160	200	240	280	
2"	1 Slot 8" Dia. Inlet	2 Ft.	Airflow, CFM	40	80	120	160	200	240	280
			Total Pressure	.007	.028	.065	.115	.180	.259	.352
			Static Pressure	.006	.025	.057	.102	.159	.229	.312
			Noise Criteria	<15	<15	<15	17	26	31	38
			Throw	1-3-8	5-8-13	7-10-15	10-13-17	11-14-19	12-15-22	13-16-23
		Airflow, CFM	100	150	200	250	300	350	400	
	4 Ft.	Total Pressure	.015	.034	.040	.094	.136	.185	.241	
		Static Pressure	.010	.022	.040	.062	.089	.122	.159	
		Noise Criteria	<15	<15	<15	15	22	30	37	
		Throw	3-4-11	6-9-14	8-12-17	9-13-19	12-14-23	14-25-27	15-17-28	
		Airflow, CFM	125	180	235	290	345	400	455	
	5 Ft.	Total Pressure	.180	.037	.064	.097	.137	.184	.238	
		Static Pressure	.010	.021	.035	.535	.076	.102	.132	
		Noise Criteria	<15	<15	<15	22	29	34	39	
		Throw	3-6-12	8-12-17	9-13-19	12-14-23	14-13-26	16-18-28	17-21-30	
Airflow, CFM		50	100	150	200	250	300	350		
2"	1 Slot 12" Oval Inlet	2 Ft.	Total Pressure	.007	.028	.064	.113	.177	.254	.346
			Static Pressure	.007	.027	.060	.108	.168	.242	.329
			Noise Criteria	<15	<15	<15	17	24	29	37
			Throw	2-5-10	5-8-12	6-10-14	8-12-17	9-13-19	10-14-22	13-16-25
			Airflow, CFM	100	170	240	310	380	450	520
		4 Ft.	Total Pressure	.008	.023	.045	.076	.114	.169	.213
	Static Pressure		.065	.019	.038	.063	.094	.132	.176	
	Noise Criteria		<15	<15	<15	20	27	33	39	
	Throw		3-6-12	7-11-15	9-13-19	11-15-23	14-17-27	15-19-30	16-21-34	
	Airflow, CFM		125	205	285	365	445	525	605	
	5 Ft.	Total Pressure	.009	.023	.045	.074	.109	.152	.202	
		Static Pressure	.007	.018	.034	.056	.083	.115	.153	
		Noise Criteria	<15	<15	<15	23	31	36	41	
		Throw	3-7-15	7-11-19	10-14-24	13-16-25	15-19-30	16-21-32	21-25-34	
		Airflow, CFM	100	145	190	235	280	325	370	
2.5"	1 Slot 10" Oval Inlet	2 Ft.	Total Pressure	.024	.05	.085	.131	.186	.25	.324
			Static Pressure	.045	.045	.077	.117	.167	.224	.291
			Noise Criteria	<15	<15	<15	22	29	35	40
			Throw	4-9-11	6-19-13	8-12-17	10-14-18	12-16-22	13-17-24	14-18-26
			Airflow, CFM	140	220	300	380	460	540	620
		4 Ft.	Total Pressure	.015	.037	.069	.111	.163	.225	.296
	Static Pressure		.010	.026	.048	.077	.112	.155	.204	
	Noise Criteria		<15	<15	<15	25	33	40	45	
	Throw		5-8-17	10-14-22	12-16-25	14-17-28	16-19-31	19-22-33	21-24-35	
	Airflow, CFM		150	240	330	420	510	600	690	
	5 Ft.	Total Pressure	.013	.034	.063	.103	.151	.209	.277	
		Static Pressure	.002	.020	.037	.060	.088	.122	.162	
		Noise Criteria	<15	<15	<15	23	31	38	43	
		Throw	3-8-16	8-12-21	12-15-25	15-18-29	17-21-32	19-23-35	21-27-38	
		Airflow, CFM	100	145	190	235	280	325	370	
2.5"	1 Slot 12" Oval Inlet	2 Ft.	Total Pressure	.021	.043	.074	.114	.161	.217	.282
			Static Pressure	.019	.041	.070	.106	.151	.204	.264
			Noise Criteria	<15	<15	<15	20	27	33	38
			Throw	4-9-11	6-19-13	8-12-17	10-14-18	12-16-22	13-17-24	14-18-26
			Airflow, CFM	140	225	310	395	480	565	650
		4 Ft.	Total Pressure	.012	.031	.059	.096	.142	.197	.261
	Static Pressure		.009	.024	.046	.075	.111	.154	.204	
	Noise Criteria		<15	<15	15	23	31	38	43	
	Throw		5-8-17	10-14-22	12-16-25	14-17-29	17-20-32	20-23-34	22-26-37	
	Airflow, CFM		150	250	350	450	550	650	750	
	5 Ft.	Total Pressure	.010	.028	.054	.090	.134	.188	.250	
		Static Pressure	.007	.019	.038	.063	.094	.131	.174	
		Noise Criteria	<15	<15	16	26	34	40	46	
		Throw	3-8-16	8-12-21	13-16-26	16-19-31	18-22-33	20-25-37	22-28-39	
		Airflow, CFM	150	250	350	450	550	650	750	

For performance table notes, see page A37.

**PERFORMANCE DATA • HORIZONTAL HIGH THROW SERIES**

**MODELS: FLH30 AND FTH30 • 1 SLOT WITH NAILOR PLENUM**

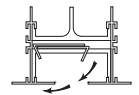

**A**

**FLOWLINE™ LINEAR DIFFUSERS**

<b>3" Slot Width</b>	<b>1 Slot 10" Oval Inlet</b>	<b>2 Ft.</b>	Airflow, CFM	125	170	215	260	305	350	395
			Total Pressure	.030	.056	.089	.131	.180	.237	.302
			Static Pressure	.027	.049	.078	.115	.158	.208	.265
			Noise Criteria	<15	<15	<15	24	29	35	40
		Throw	7-11-16	9-13-19	11-15-21	13-17-23	15-18-25	16-19-28	17-20-31	
		<b>4 Ft.</b>	Airflow, CFM	200	275	350	425	500	575	650
	Total Pressure		.027	.050	.081	.120	.166	.220	.281	
	Static Pressure		.017	.032	.052	.076	.106	.140	.179	
	Noise Criteria		<15	<15	18	22	28	34	40	
	<b>5 Ft.</b>	Airflow, CFM	220	310	400	490	580	670	760	
		Total Pressure	.025	.040	.082	.123	.172	.230	.296	
		Static Pressure	.013	.026	.043	.065	.091	.122	.157	
Noise Criteria		<15	<15	16	24	32	39	45		
<b>3" Slot Width</b>	<b>1 Slot 12" Oval Inlet</b>	<b>2 Ft.</b>	Airflow, CFM	125	170	215	260	305	350	395
			Total Pressure	.029	.053	.085	.124	.170	.224	.286
			Static Pressure	.026	.049	.078	.115	.158	.208	.265
			Noise Criteria	<15	<15	<15	18	25	31	36
		Throw	7-11-16	9-13-19	11-15-21	13-17-23	15-18-25	16-19-28	17-20-31	
		<b>4 Ft.</b>	Airflow, CFM	200	290	380	470	560	650	740
	Total Pressure		.022	.047	.081	.123	.175	.236	.306	
	Static Pressure		.017	.036	.061	.094	.133	.179	.232	
	Noise Criteria		<15	<15	<15	22	29	36	41	
	<b>5 Ft.</b>	Airflow, CFM	220	330	440	550	660	770	880	
		Total Pressure	.020	.044	.079	.123	.177	.241	.315	
		Static Pressure	.013	.030	.053	.082	.118	.161	.210	
Noise Criteria		<15	<15	19	26	32	39	43		
<b>3" Slot Width</b>	<b>1 Slot 12" Oval Inlet</b>	<b>2 Ft.</b>	Airflow, CFM	125	170	215	260	305	350	395
			Total Pressure	.030	.056	.089	.131	.180	.237	.302
			Static Pressure	.027	.049	.078	.115	.158	.208	.265
			Noise Criteria	<15	<15	<15	24	29	35	40
		Throw	7-11-16	9-13-19	11-15-21	13-17-23	15-18-25	16-19-28	17-20-31	
		<b>4 Ft.</b>	Airflow, CFM	200	275	350	425	500	575	650
	Total Pressure		.027	.050	.081	.120	.166	.220	.281	
	Static Pressure		.017	.032	.052	.076	.106	.140	.179	
	Noise Criteria		<15	<15	18	22	28	34	40	
	<b>5 Ft.</b>	Airflow, CFM	220	310	400	490	580	670	760	
		Total Pressure	.025	.040	.082	.123	.172	.230	.296	
		Static Pressure	.013	.026	.043	.065	.091	.122	.157	
Noise Criteria		<15	<15	16	24	32	39	45		
<b>3" Slot Width</b>	<b>1 Slot 12" Oval Inlet</b>	<b>2 Ft.</b>	Airflow, CFM	125	170	215	260	305	350	395
			Total Pressure	.029	.053	.085	.124	.170	.224	.286
			Static Pressure	.026	.049	.078	.115	.158	.208	.265
			Noise Criteria	<15	<15	<15	18	25	31	36
		Throw	7-11-16	9-13-19	11-15-21	13-17-23	15-18-25	16-19-28	17-20-31	
		<b>4 Ft.</b>	Airflow, CFM	200	290	380	470	560	650	740
	Total Pressure		.022	.047	.081	.123	.175	.236	.306	
	Static Pressure		.017	.036	.061	.094	.133	.179	.232	
	Noise Criteria		<15	<15	<15	22	29	36	41	
	<b>5 Ft.</b>	Airflow, CFM	220	330	440	550	660	770	880	
		Total Pressure	.020	.044	.079	.123	.177	.241	.315	
		Static Pressure	.013	.030	.053	.082	.118	.161	.210	
Noise Criteria		<15	<15	19	26	32	39	43		
<b>3" Slot Width</b>	<b>1 Slot 12" Oval Inlet</b>	<b>2 Ft.</b>	Airflow, CFM	125	170	215	260	305	350	395
			Total Pressure	.029	.053	.085	.124	.170	.224	.286
			Static Pressure	.026	.049	.078	.115	.158	.208	.265
			Noise Criteria	<15	<15	<15	18	25	31	36
		Throw	7-11-16	9-13-19	11-15-21	13-17-23	15-18-25	16-19-28	17-20-31	
		<b>4 Ft.</b>	Airflow, CFM	200	290	380	470	560	650	740
	Total Pressure		.022	.047	.081	.123	.175	.236	.306	
	Static Pressure		.017	.036	.061	.094	.133	.179	.232	
	Noise Criteria		<15	<15	<15	22	29	36	41	
	<b>5 Ft.</b>	Airflow, CFM	220	330	440	550	660	770	880	
		Total Pressure	.020	.044	.079	.123	.177	.241	.315	
		Static Pressure	.013	.030	.053	.082	.118	.161	.210	
Noise Criteria		<15	<15	19	26	32	39	43		

**Performance Notes:**

1. Data is based upon FlowLine™ with Nailor engineered plenum (uninsulated) as a complete assembly.
2. All pressures are in inches w.g..
3. Throw values are given at 150, 100 and 50 fpm terminal velocities under isothermal conditions.
4. Noise criteria values are based on 10 dB room absorption, re 10<sup>-12</sup> watts.
5. Throw values are based on a 1-way air pattern. For 2-way pattern, throw is determined from the 1 slot data at half the specified air volume.
6. Data derived from tests conducted in accordance with ANSI/ASHRAE Standard 70-2006.

PERFORMANCE DATA • HORIZONTAL HIGH THROW SERIES

MODELS: FLH / FTH (10 & 15) • 2 SLOT WITH NAILOR PLENUM

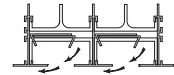

FLOWLINE™ LINEAR DIFFUSERS

1" Slot Width	2 Slot 8" Dia. Inlet	2 Ft.	Airflow, CFM	80	120	160	200	240	280	320
			Total Pressure	.016	.036	.064	.101	.145	.198	.258
			Static Pressure	.018	.041	.072	.080	.115	.157	.205
			Noise Criteria	<15	<15	<15	23	29	35	40
		Throw	3-6-12	6-10-16	9-13-18	11-14-20	13-16-22	14-17-23	15-18-25	
		4 Ft.	Airflow, CFM	160	230	300	370	440	510	580
			Total Pressure	.025	.053	.091	.138	.196	.263	.340
			Static Pressure	.013	.026	.045	.068	.097	.130	.168
			Noise Criteria	<15	<15	17	24	31	36	41
		Throw	5-8-17	8-12-21	10-16-24	13-18-26	16-20-30	17-22-32	18-24-34	
		5 Ft.	Airflow, CFM	200	280	360	440	520	600	680
			Total Pressure	.033	.065	.108	.161	.225	.300	.385
Static Pressure	.013		.025	.041	.062	.087	.115	.148		
Noise Criteria	<15		<15	19	26	32	37	42		
Throw	5-10-20	9-14-24	12-17-26	15-20-30	17-22-33	19-24-35	22-26-38			
1" Slot Width	2 Slot 10" Dia. Inlet	2 Ft.	Airflow, CFM	80	130	180	230	280	330	380
			Total Pressure	.014	.038	.073	.119	.176	.244	.324
			Static Pressure	.013	.034	.065	.106	.157	.218	.289
			Noise Criteria	<15	<15	19	28	35	41	47
		Throw	3-6-13	7-11-16	10-14-19	12-15-22	13-17-24	14-18-26	15-19-28	
		4 Ft.	Airflow, CFM	160	240	320	400	480	560	640
			Total Pressure	.019	.043	.076	.118	.170	.232	.303
			Static Pressure	.013	.029	.051	.080	.115	.157	.205
			Noise Criteria	<15	<15	18	26	33	39	44
		Throw	4-9-18	9-14-22	12-28-26	15-20-29	17-22-32	20-24-34	19-25-35	
		5 Ft.	Airflow, CFM	200	295	390	485	580	675	770
			Total Pressure	.022	.048	.085	.132	.189	.256	.333
Static Pressure	.013		.028	.049	.075	.108	.146	.190		
Noise Criteria	<15		<15	20	28	34	40	45		
Throw	5-19-19	10-14-24	13-19-27	17-22-32	20-24-35	21-25-38	22-27-39			
1.5" Slot Width	2 Slot 8" Dia. Inlet	2 Ft.	Airflow, CFM	120	160	200	240	280	320	360
			Total Pressure	.036	.064	.101	.145	.198	.258	.327
			Static Pressure	.029	.051	.080	.115	.157	.205	.259
			Noise Criteria	<15	<15	19	26	32	37	41
		Throw	5-19-16	8-12-18	11-12-18	13-16-21	14-17-24	15-18-26	15-19-27	
		4 Ft.	Airflow, CFM	240	310	380	450	520	590	660
			Total Pressure	.058	.097	.146	.205	.274	.352	.441
			Static Pressure	.029	.048	.072	.101	.135	.174	.218
			Noise Criteria	<15	<15	21	27	33	37	42
		Throw	9-14-22	12-17-25	14-20-28	16-22-31	17-23-33	19-25-35	21-26-37	
		5 Ft.	Airflow, CFM	300	370	440	510	580	650	720
			Total Pressure	.075	.114	.161	.217	.281	.352	.432
Static Pressure	.029		.044	.062	.083	.108	.135	.166		
Noise Criteria	<15		<15	22	27	32	36	40		
Throw	10-15-25	13-19-28	15-21-30	16-22-32	18-23-33	19-24-34	21-27-38			
1.5" Slot Width	2 Slot 12" Dia. Inlet	2 Ft.	Airflow, CFM	120	170	220	270	320	370	420
			Total Pressure	.031	.062	.103	.156	.219	.293	.377
			Static Pressure	.029	.058	.097	.146	.205	.274	.353
			Noise Criteria	<15	<15	21	29	35	40	45
		Throw	5-9-16	9-13-19	12-14-21	14-16-24	15-18-26	15-19-28	17-21-29	
		4 Ft.	Airflow, CFM	240	320	400	480	560	640	720
			Total Pressure	.037	.065	.102	.146	.199	.260	.329
			Static Pressure	.029	.051	.080	.115	.157	.205	.259
			Noise Criteria	<15	<15	22	26	32	37	41
		Throw	9-14-22	12-18-26	15-20-29	17-22-32	18-24-33	20-26-36	22-27-39	
		5 Ft.	Airflow, CFM	300	400	500	600	700	800	900
			Total Pressure	.041	.073	.114	.163	.222	.291	.368
Static Pressure	.029		.051	.080	.115	.157	.205	.259		
Noise Criteria	<15		<15	23	30	35	40	45		
Throw	10-15-25	14-20-29	16-22-32	19-24-35	22-27-38	23-28-41	24-30-43			

For performance table notes, see page A40.

**PERFORMANCE DATA • HORIZONTAL HIGH THROW SERIES**

**MODELS: FLH / FTH (20 & 25) • 2 SLOT WITH NAILOR PLENUM**

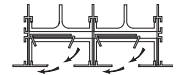

**A**

**FLOWLINE™ LINEAR DIFFUSERS**

<b>2" Slot Width</b>	<b>2 Slot 8" Dia. Inlet</b>	<b>2 Ft.</b>	Airflow, CFM	120	165	210	255	300	345	390
			Total Pressure	.023	.043	.069	.101	.141	.186	.238
			Static Pressure	.015	.029	.047	.068	.095	.125	.160
			Noise Criteria	<15	<15	16	24	29	34	38
			Throw	5-8-14	7-11-16	9-14-19	11-14-21	13-16-23	14-17-24	14-18-25
		<b>4 Ft.</b>	Airflow, CFM	240	300	360	420	480	540	600
			Total Pressure	.051	.079	.114	.156	.204	.258	.318
			Static Pressure	.021	.034	.048	.066	.086	.108	.134
			Noise Criteria	<15	17	23	29	34	39	43
			Throw	6-11-20	9-14-23	11-16-24	13-19-26	14-20-29	16-22-30	18-23-32
		<b>5 Ft.</b>	Airflow, CFM	260	325	390	455	520	585	650
			Total Pressure	.053	.082	.118	.161	.211	.267	.329
			Static Pressure	.018	.028	.040	.055	.072	.092	.113
			Noise Criteria	<15	16	22	29	34	38	42
			Throw	5-11-21	8-14-23	11-16-25	13-18-28	14-21-30	16-23-32	17-23-33
<b>2" Slot Width</b>	<b>2 Slot 12" Dia. Inlet</b>	<b>2 Ft.</b>	Airflow, CFM	120	195	270	345	420	495	570
			Total Pressure	.009	.024	.046	.075	.111	.155	.205
			Static Pressure	.007	.020	.039	.063	.094	.130	.172
			Noise Criteria	<15	<15	<15	22	28	35	41
			Throw	5-8-14	8-13-18	12-15-22	14-17-24	15-19-26	16-21-29	18-20-31
		<b>4 Ft.</b>	Airflow, CFM	240	330	420	510	600	690	780
			Total Pressure	.019	.037	.060	.088	.122	.161	.206
			Static Pressure	.013	.026	.042	.062	.086	.113	.145
			Noise Criteria	<15	<15	17	24	30	35	41
			Throw	6-11-20	10-15-23	13-19-26	15-21-29	18-23-32	20-24-34	21-25-36
		<b>5 Ft.</b>	Airflow, CFM	280	380	480	580	680	780	880
			Total Pressure	.022	.040	.065	.094	.130	.172	.218
			Static Pressure	.014	.026	.041	.060	.083	.110	.140
			Noise Criteria	<15	<15	18	25	31	36	41
			Throw	5-12-22	10-15-25	13-20-29	15-22-32	18-24-34	21-25-36	23-27-39
<b>2.5" Slot Width</b>	<b>2 Slot 10" Dia. Inlet</b>	<b>2 Ft.</b>	Airflow, CFM	80	160	240	320	400	480	560
			Total Pressure	.005	.019	.043	.078	.122	.175	.238
			Static Pressure	.003	.014	.032	.057	.088	.127	.173
			Noise Criteria	<15	<15	<15	18	27	35	41
			Throw	2-4-10	6-10-16	10-14-20	13-16-23	15-18-26	16-20-29	18-22-31
		<b>4 Ft.</b>	Airflow, CFM	160	280	400	520	640	760	880
			Total Pressure	.011	.034	.070	.118	.178	.251	.336
			Static Pressure	.005	.018	.036	.061	.092	.130	.174
			Noise Criteria	<15	<15	<15	22	31	38	44
			Throw	3-15-14	7-12-22	12-17-26	15-21-30	18-23-32	21-25-36	23-27-39
		<b>5 Ft.</b>	Airflow, CFM	200	335	470	605	740	875	1010
			Total Pressure	.014	.040	.079	.130	.194	.271	.361
			Static Pressure	.005	.016	.032	.054	.079	.110	.147
			Noise Criteria	<15	<15	<15	23	31	38	44
			Throw	3-5-15	7-13-23	12-18-28	15-23-32	19-25-35	23-27-29	23-29-41
<b>2.5" Slot Width</b>	<b>2 Slot 12" Dia. Inlet</b>	<b>2 Ft.</b>	Airflow, CFM	80	170	260	350	440	530	620
			Total Pressure	.003	.015	.034	.061	.097	.140	.192
			Static Pressure	.002	.012	.027	.049	.077	.112	.153
			Noise Criteria	<15	<15	<15	17	27	34	41
			Throw	2-4-10	7-10-17	11-14-21	14-17-24	15-19-27	17-21-31	19-23-32
		<b>4 Ft.</b>	Airflow, CFM	160	295	430	595	700	835	970
			Total Pressure	.007	.024	.051	.088	.136	.193	.260
			Static Pressure	.004	.016	.033	.056	.086	.122	.165
			Noise Criteria	<15	<15	<15	21	29	37	43
			Throw	3-5-14	8-13-23	13-19-27	16-22-31	20-24-34	22-26-38	23-29-41
		<b>5 Ft.</b>	Airflow, CFM	200	350	500	650	800	950	1100
			Total Pressure	.010	.029	.059	.100	.151	.212	.284
			Static Pressure	.005	.017	.033	.057	.086	.121	.162
			Noise Criteria	<15	<15	<15	21	29	37	43
			Throw	3-5-15	8-14-24	13-19-29	17-23-33	21-26-37	23-28-40	25-31-43

For performance table notes, see page A40.

**PERFORMANCE DATA • HORIZONTAL HIGH THROW SERIES**

**MODELS: FLH30 AND FTH30 • 2 SLOT WITH NAILOR PLENUM**

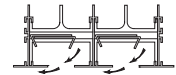

**FLOWLINE™ LINEAR DIFFUSERS**

3" Slot Width	2 Slot 10" Dia. Inlet	2 Ft.	Airflow, CFM	80	180	280	380	480	580	680
			Total Pressure	.004	.022	.053	.097	.155	.226	.311
Static Pressure	.003	.015	.036	.067	.106	.156	.214			
Noise Criteria	<15	<15	<15	17	28	36	43			
Throw	1-3-9	6-10-17	11-15-22	14-18-25	16-20-29	18-22-32	20-24-34			
3" Slot Width	2 Slot 12" Dia. Inlet	4 Ft.	Airflow, CFM	150	300	450	600	750	900	1050
			Total Pressure	.009	.035	.080	.143	.222	.321	.436
Static Pressure	.004	.016	.038	.067	.104	.151	.205			
Noise Criteria	<15	<15	<15	19	29	38	45			
Throw	2-4-12	6-12-23	12-18-28	16-23-32	20-25-35	23-28-39	24-30-42			
3" Slot Width	2 Slot 12" Dia. Inlet	5 Ft.	Airflow, CFM	180	350	520	690	860	1030	1200
			Total Pressure	.011	.042	.092	.162	.251	.360	.489
Static Pressure	.004	.016	.035	.062	.096	.138	.186			
Noise Criteria	<15	<15	<15	19	29	38	45			
Throw	2-4-13	6-13-24	13-19-30	16-24-34	21-27-38	24-30-41	26-32-45			
3" Slot Width	2 Slot 10" Dia. Inlet	2 Ft.	Airflow, CFM	80	180	280	380	480	580	680
			Total Pressure	.004	.017	.042	.077	.124	.180	.248
Static Pressure	.003	.014	.034	.063	.100	.146	.201			
Noise Criteria	<15	<15	<15	<15	23	32	39			
Throw	1-3-9	6-10-17	11-15-22	14-18-25	16-20-29	18-22-32	20-24-34			
3" Slot Width	2 Slot 12" Dia. Inlet	4 Ft.	Airflow, CFM	150	310	470	630	790	950	1110
			Total Pressure	.006	.024	.056	.100	.156	.226	.309
Static Pressure	.003	.014	.033	.059	.093	.135	.184			
Noise Criteria	<15	<15	<15	23	29	35	42			
Throw	2-4-12	7-13-23	13-19-28	17-23-32	21-26-36	23-28-40	25-31-43			
3" Slot Width	2 Slot 12" Dia. Inlet	5 Ft.	Airflow, CFM	180	360	540	720	900	1080	1260
			Total Pressure	.007	.027	.060	.108	.169	.244	.331
Static Pressure	.003	.014	.031	.056	.087	.126	.170			
Noise Criteria	<15	<15	16	24	30	35	42			
Throw	2-4-13	6-13-24	13-19-30	17-24-35	22-28-39	24-30-42	26-32-46			

**Performance Notes:**

1. Data is based upon FlowLine™ with Nailor engineered plenum (uninsulated) as a complete assembly.
2. All pressures are in inches w.g..
3. Throw values are given at 150, 100 and 50 fpm terminal velocities under isothermal conditions.
4. Noise criteria values are based on 10 dB room absorption, re 10<sup>-12</sup> watts.
5. Throw values are based on a 1-way air pattern. For 2-way pattern, throw is determined from the 1 slot data at half the specified air volume.
6. Data derived from tests conducted in accordance with ANSI/ASHRAE Standard 70-2006.



**PERFORMANCE DATA • HORIZONTAL HIGH THROW SERIES**

**MODELS: FLH (10, 15, 20, 25 & 30) • CONTINUOUS PRESSURIZED PLENUM**

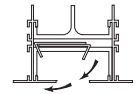

**A**

**FLOWLINE™ LINEAR DIFFUSERS**

Slot Width	Slots	Airflow, CFM/FT.	20	35	50	65	80	95	110
		Static Pressure	.013	.039	.080	.135	.205	.289	.387
Noise Criteria	<15	<15	23	30	36	42	45		
Throw	4-6-12	7-11-16	10-14-20	13-16-22	15-18-25	16-20-27	17-21-30		
1" Slot Width	1 Slot	Airflow, CFM/FT.	20	35	50	65	80	95	110
		Static Pressure	.013	.039	.080	.135	.205	.289	.387
Noise Criteria	<15	<15	23	30	36	42	45		
Throw	4-6-12	7-11-16	10-14-20	13-16-22	15-18-25	16-20-27	17-21-30		
1" Slot Width	2 Slot	Airflow, CFM/FT.	40	70	100	130	160	190	220
		Static Pressure	.013	.039	.080	.135	.205	.289	.387
Noise Criteria	<15	<15	25	33	39	45	48		
Throw	5-8-17	10-15-24	15-20-29	17-22-32	19-25-35	20-28-38	22-30-40		
1.5" Slot Width	1 Slot	Airflow, CFM/FT.	25	40	55	70	85	100	115
		Static Pressure	.011	.029	.054	.089	.130	.180	.237
		Noise Criteria	<15	<15	17	25	31	36	40
		Throw	5-8-12	9-12-17	12-15-20	14-17-22	15-18-25	16-20-28	17-21-30
1.5" Slot Width	2 Slot	Airflow, CFM/FT.	55	80	105	130	155	180	205
		Static Pressure	.014	.029	.049	.076	.108	.145	.189
		Noise Criteria	<15	<15	16	26	31	35	39
		Throw	8-12-19	12-17-25	15-20-29	17-22-31	20-26-35	21-27-39	23-30-40
2" Slot Width	1 Slot	Airflow, CFM/FT.	25	45	65	85	105	125	145
		Static Pressure	.007	.021	.044	.075	.115	.163	.219
		Noise Criteria	<15	<15	19	24	32	38	43
		Throw	4-8-13	8-12-18	11-16-22	14-19-26	16-21-30	17-22-31	20-24-34
2" Slot Width	2 Slot	Airflow, CFM/FT.	45	85	125	165	205	245	285
		Static Pressure	.005	.019	.042	.073	.113	.161	.218
		Noise Criteria	<15	<15	19	26	34	40	45
		Throw	4-9-15	11-16-25	16-21-29	21-26-37	23-28-40	26-31-42	27-32-44
2.5" Slot Width	1 Slot	Airflow, CFM/FT.	30	55	80	105	130	155	180
		Static Pressure	.009	.031	.065	.113	.173	.245	.331
		Noise Criteria	<15	<15	18	25	30	34	39
		Throw	3-7-16	9-14-21	13-18-26	15-20-29	18-22-33	20-25-36	21-27-39
2.5" Slot Width	2 Slot	Airflow, CFM/FT.	60	105	150	195	240	285	330
		Static Pressure	.009	.028	.057	.097	.147	.207	.278
		Noise Criteria	<15	<15	21	27	32	37	41
		Throw	7-12-22	13-19-28	19-24-35	22-27-39	25-31-44	27-33-48	29-36-51
3" Slot Width	1 Slot	Airflow, CFM/FT.	30	60	90	120	150	180	210
		Static Pressure	.008	.033	.074	.131	.205	.296	.403
		Noise Criteria	<15	<15	15	24	30	35	40
		Throw	3-6-15	10-14-22	14-19-27	17-23-32	19-25-35	22-27-39	24-29-42
3" Slot Width	2 Slot	Airflow, CFM/FT.	60	120	180	240	300	360	420
		Static Pressure	.008	.033	.074	.131	.205	.296	.403
		Noise Criteria	<15	<15	18	27	33	38	43
		Throw	4-9-20	12-20-31	19-26-38	24-31-44	27-34-48	30-37-53	32-40-57

**NC Correction Factors for Various Lengths**

Length (ft.)	2	4	6	8	9	10	15
Supply	-3	0	+2	+3	+4	+5	+8
Return	0	+3	+5	+6	+7	+8	+11

**Throw Correction Factors for Various Lengths**

Length (ft.)	2	4	6	8	10	12
Multiplier	0.70	1.00	1.25	1.40	1.55	1.70

**Performance Notes:**

- Data is based upon pressurized plenum application (non ducted) with no plenum effect for pressure or sound. Plenums should be sized to achieve equal velocity along the slot length. Keep duct inlet velocities below 700 fpm in order to maintain cataloged performance.
- All pressures are in inches w.g..
- Throw values are given at 150, 100 and 50 fpm terminal velocities under isothermal conditions.
- Throw data is based on active sections 4 ft. (1219) long. For other lengths, use the correction factor table above.
- Noise criteria values are based on 10 dB room absorption, re 10<sup>-12</sup> watts, for a 4 ft. section. For other lengths, use the correction factor table above.
- Throw values are based on a 1-way air pattern. For 2-way pattern, throw is determined from the 1 slot data at half the specified air volume.
- Data derived from tests conducted in accordance with ANSI/ASHRAE Standard 70-2006.

**PERFORMANCE DATA • RETURN (NO PATTERN CONTROLLERS)**

**MODELS: FLR (10, 15, 20, 25 & 30) • CONTINUOUS SLOT**

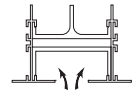

**A**

**FLOWLINE™ LINEAR DIFFUSERS**

Slot Width	Slots	Airflow, CFM/FT.							
		20	40	60	80	100	120	140	
1"	1 Slot	Neg. Static Pressure	.008	.029	.066	.118	.182	.262	.357
		Noise Criteria	—	—	<20	24	28	34	39
		Airflow, CFM/FT.	40	85	130	175	220	265	310
	2 Slot	Neg. Static Pressure	.008	.038	.090	.163	.258	.374	.512
		Noise Criteria	—	<15	23	27	32	37	42
		Airflow, CFM/FT.	30	60	90	120	150	180	210
1.5"	1 Slot	Neg. Static Pressure	.008	.032	.072	.128	.200	.288	.392
		Noise Criteria	—	—	<15	23	29	35	40
		Airflow, CFM/FT.	60	120	180	240	300	360	420
	2 Slot	Neg. Static Pressure	.010	.037	.083	.149	.232	.334	.456
		Noise Criteria	—	<15	16	24	31	37	43
		Airflow, CFM/FT.	35	75	115	155	195	235	275
2"	1 Slot	Neg. Static Pressure	.006	.030	.070	.128	.202	.293	.402
		Noise Criteria	<15	15	21	25	29	34	39
		Airflow, CFM/FT.	70	150	230	310	390	470	550
	2 Slot	Neg. Static Pressure	.008	.035	.082	.147	.234	.339	.466
		Noise Criteria	<15	18	24	26	32	37	42
		Airflow, CFM/FT.	40	95	150	205	260	315	370
2.5"	1 Slot	Neg. Static Pressure	.006	.028	.070	.132	.211	.311	.431
		Noise Criteria	<15	<15	16	24	29	35	48
		Airflow, CFM/FT.	80	190	300	410	520	630	740
	2 Slot	Neg. Static Pressure	.006	.039	.081	.151	.244	.358	.494
		Noise Criteria	<15	<15	20	26	32	38	51
		Airflow, CFM/FT.	50	115	180	245	310	375	440
3"	1 Slot	Neg. Static Pressure	.006	.029	.073	.136	.217	.316	.437
		Noise Criteria	<15	<15	16	26	32	37	42
		Airflow, CFM/FT.	100	230	360	490	620	750	880
	2 Slot	Neg. Static Pressure	.007	.035	.084	.157	.251	.365	.540
		Noise Criteria	<15	<15	21	29	35	40	45
		Airflow, CFM/FT.	50	115	180	245	310	375	440

**NC Correction Factors for Various Lengths**

Length (ft.)	2	4	6	8	9	10	15
Correction	-3	0	+2	+3	+4	+5	+8

**Performance Notes:**

- Data is based upon a negative pressurized plenum application (non ducted) with no plenum effect for pressure or sound. Plenums should be sized to achieve equal velocity along the slot length. Keep duct inlet velocities below 700 fpm in order to maintain cataloged performance.
- All pressures are in inches w.g..
- Noise criteria (NC) shown is based on active sections 4 ft. (1219) long. For other lengths, use the correction factor table above.
- Noise criteria values are based on 10 dB room absorption, re 10<sup>-12</sup> watts, for a 4 ft. section. For other lengths, use the correction factor table above.
- Data derived from tests conducted in accordance with ANSI/ASHRAE Standard 70-2006.

**PERFORMANCE DATA • RETURN AIR APPLICATIONS**

**MODELS: FLH (10, 15, 20, 25 & 30)**

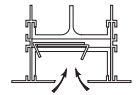

**FLOWLINE™ LINEAR DIFFUSERS**

Slot Width	Slots	Airflow, CFM/FT.	20	35	50	65	80	95	110	
		Static Pressure	.014	.043	.088	.149	.226	.318	.426	
		Noise Criteria	<15	<18	26	33	39	45	48	
1" Slot Width	1 Slot	Airflow, CFM/FT.	20	35	50	65	80	95	110	
		Static Pressure	.014	.043	.088	.149	.226	.318	.426	
		Noise Criteria	<15	<18	26	33	39	45	48	
1" Slot Width	2 Slot	Airflow, CFM/FT.	40	70	100	130	160	190	220	
		Static Pressure	.014	.043	.088	.149	.226	.318	.426	
		Noise Criteria	<15	<19	28	36	42	48	51	
1.5" Slot Width	1 Slot	Airflow, CFM/FT.	25	40	55	70	85	100	115	
		Static Pressure	.012	.032	.059	.098	.143	.198	.261	
		Noise Criteria	<15	<15	20	28	34	39	43	
	1.5" Slot Width	2 Slot	Airflow, CFM/FT.	55	80	105	130	155	180	205
			Static Pressure	.015	.032	.054	.084	.119	.160	.208
			Noise Criteria	<15	<15	19	29	34	38	42
2" Slot Width	1 Slot	Airflow, CFM/FT.	25	45	65	85	105	125	145	
		Static Pressure	.008	.023	.048	.083	.127	.179	.241	
		Noise Criteria	<15	<15	22	27	35	41	46	
	2" Slot Width	2 Slot	Airflow, CFM/FT.	45	85	125	165	205	245	285
			Static Pressure	.006	.021	.046	.080	.124	.177	.240
			Noise Criteria	<15	<15	22	29	37	43	48
2.5" Slot Width	1 Slot	Airflow, CFM/FT.	30	55	80	105	130	155	180	
		Static Pressure	.010	.034	.074	.124	.190	.270	.364	
		Noise Criteria	<15	<15	21	28	33	37	42	
	2.5" Slot Width	2 Slot	Airflow, CFM/FT.	60	105	150	195	240	285	330
			Static Pressure	.010	.031	.063	.107	.162	.228	.306
			Noise Criteria	<15	<15	24	30	35	40	44
3" Slot Width	1 Slot	Airflow, CFM/FT.	30	60	90	120	150	180	210	
		Static Pressure	.009	.036	.081	.144	.226	.326	.443	
		Noise Criteria	<15	<15	18	27	33	38	43	
	3" Slot Width	2 Slot	Airflow, CFM/FT.	60	120	180	240	300	360	420
			Static Pressure	.009	.036	.081	.144	.226	.326	.443
			Noise Criteria	<15	<15	22	30	36	41	46

**NC Correction Factors for Various Lengths**

Length (ft.)	2	4	6	8	9	10	15
Return	- 3	0	+ 1	+ 2	+ 3	+ 5	+ 7

**Performance Notes:**

1. Data is based upon a ductless return application.
2. All pressures are in inches w.g..
3. Noise criteria values are based on 10 dB room absorption, re 10<sup>-12</sup> watts, for a 4 ft. (1219) section. For other lengths, use the correction factor table above.
4. Data derived from tests conducted in accordance with ANSI/ASHRAE Standard 70-2006.

**PERFORMANCE DATA • VERTICAL JET THROW SERIES**

**MODELS: FLV (10, 15, 20, 25 & 30) • CONTINUOUS PRESSURIZED PLENUM**

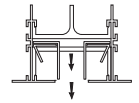

**A**

**FLOWLINE™ LINEAR DIFFUSERS**

Slot Width	Slots	Airflow, CFM/FT.	20	40	60	80	100	120	140
		Static Pressure	.005	.018	.041	.074	.114	.164	.223
Noise Criteria	—	—	<15	20	24	30	35		
Throw	1-3-10	4-10-21	10-15-29	14-21-33	18-26-37	21-19-41	24-31-44		
1" Slot Width	1 Slot	Airflow, CFM/FT.	20	40	60	80	100	120	140
		Static Pressure	.005	.018	.041	.074	.114	.164	.223
Noise Criteria	—	—	<15	20	24	30	35		
Throw	1-3-10	4-10-21	10-15-29	14-21-33	18-26-37	21-19-41	24-31-44		
1" Slot Width	2 Slot	Airflow, CFM/FT.	40	85	130	175	220	265	310
		Static Pressure	.005	.024	.056	.102	.161	.234	.320
Noise Criteria	—	<15	20	27	32	37	42		
Throw	2-4-17	9-18-32	19-28-40	25-32-45	30-36-51	32-40-56	35-43-61		
1.5" Slot Width	1 Slot	Airflow, CFM/FT.	30	60	90	120	150	180	210
		Static Pressure	.005	.020	.045	.080	.125	.180	.245
Noise Criteria	—	—	<15	20	26	32	37		
Throw	1-3-12	6-12-24	12-19-34	17-24-40	21-31-44	24-34-48	29-36-52		
1.5" Slot Width	2 Slot	Airflow, CFM/FT.	60	120	180	240	300	360	420
		Static Pressure	.006	.023	.052	.093	.145	.209	.285
Noise Criteria	—	<15	16	24	31	37	43		
Throw	2-6-20	9-20-36	20-31-44	28-36-51	33-41-57	36-44-63	39-47-67		
2" Slot Width	1 Slot	Airflow, CFM/FT.	35	75	115	155	195	235	275
		Static Pressure	.004	.019	.044	.080	.126	.183	.251
Noise Criteria	<15	15	21	25	29	34	39		
Throw	1-2-8	4-9-20	9-15-29	14-21-33	18-26-37	21-29-41	25-31-44		
2" Slot Width	2 Slot	Airflow, CFM/FT.	70	150	230	310	390	470	550
		Static Pressure	.005	.022	.051	.092	.146	.212	.291
Noise Criteria	<15	19	25	29	34	39	44		
Throw	2-3-13	7-14-30	15-26-37	23-31-43	28-34-48	31-37-54	33-41-58		
2.5" Slot Width	1 Slot	Airflow, CFM/FT.	40	95	150	205	260	315	370
		Static Pressure	.004	.020	.050	.094	.151	.222	.306
Noise Criteria	<15	<15	16	24	29	35	48		
Throw	1-2-7	4-10-22	11-18-31	16-25-37	20-30-42	25-32-42	29-36-50		
2.5" Slot Width	2 Slot	Airflow, CFM/FT.	80	190	300	410	520	630	740
		Static Pressure	.004	.023	.058	.108	.174	.256	.353
Noise Criteria	<15	<15	20	26	35	41	46		
Throw	1-3-11	7-16-33	18-29-42	26-34-48	31-38-54	35-43-60	37-46-65		
3" Slot Width	1 Slot	Airflow, CFM/FT.	50	115	180	245	310	375	440
		Static Pressure	.004	.021	.052	.097	.155	.226	.312
Noise Criteria	<15	<15	16	26	32	37	42		
Throw	1-2-8	5-11-25	12-20-34	17-26-40	22-31-45	26-35-49	31-37-54		
3" Slot Width	2 Slot	Airflow, CFM/FT.	100	230	360	490	620	750	880
		Static Pressure	.005	.025	.060	.112	.179	.261	.360
Noise Criteria	<15	<15	21	29	36	41	45		
Throw	2-3-13	8-17-36	19-31-44	29-37-52	33-41-58	37-45-64	40-49-70		

**NC Correction Factors for Various Lengths**

Length (ft.)	2	4	6	8	9	10	15
Supply	-3	0	+2	+3	+4	+5	+8
Return	0	+3	+5	+6	+7	+8	+11

**Throw Correction Factors for Various Lengths**

Length (ft.)	2	4	6	8	10	12
Multiplier	0.80	1.00	1.20	1.30	1.40	1.50

**Performance Notes:**

- Data is based upon pressurized plenum application (non ducted) with no plenum effect for pressure or sound. Plenums should be sized to achieve equal velocity along the slot length. Keep duct inlet velocities below 700 fpm in order to maintain cataloged performance.
- All pressures are in inches w.g..
- Throw values are given at 150, 100 and 50 fpm terminal velocities under isothermal conditions.
- Throw data is based on active sections 4 ft. (1219) long. For other lengths, use the correction factor table above.
- Throw values are based on pattern controller set 100% open.
- Noise criteria values are based on 10 dB room absorption, re 10<sup>-12</sup> watts, for a 4 ft. section. For other lengths, use the correction factor table above.
- Data derived from tests conducted in accordance with ANSI/ASHRAE Standard 70-2006.

PERFORMANCE DATA • VERTICAL JET THROW SERIES

MODELS: FLV / FTV (10 & 15) • 1 SLOT WITH NAILOR PLENUM

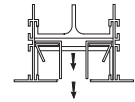

FLOWLINE™ LINEAR DIFFUSERS

1" Slot Width	1 Slot 8" Dia. Inlet	2 Ft.	Airflow, CFM	50	95	140	185	230	275	320
			Total Pressure	.010	.033	.073	.127	.197	.281	.381
			Static Pressure	.007	.029	.062	.109	.168	.241	.325
			Noise Criteria	<15	<15	17	26	33	39	44
			Throw	2-3-10	7-9-19	9-14-24	12-19-28	15-22-31	18-24-34	21-26-36
		4 Ft.	Airflow, CFM	100	175	250	325	400	475	550
			Total Pressure	.018	.056	.113	.190	.289	.408	.547
			Static Pressure	.013	.039	.079	.133	.201	.285	.381
			Noise Criteria	<15	<15	20	29	35	41	46
			Throw	2-4-13	6-11-23	11-17-30	14-21-34	18-26-37	21-29-41	24-31-44
		5 Ft.	Airflow, CFM	110	195	280	365	450	535	620
			Total Pressure	.019	.060	.124	.212	.322	.455	.611
			Static Pressure	.013	.040	.081	.139	.211	.297	.400
			Noise Criteria	<15	<15	21	30	36	42	47
			Throw	1-3-12	6-11-22	10-17-31	14-21-35	18-25-39	21-30-42	23-32-45
1" Slot Width	1 Slot 10" Oval Inlet	2 Ft.	Airflow, CFM	50	95	140	185	230	275	320
			Total Pressure	.006	.022	.049	.087	.134	.192	.259
			Static Pressure	.005	.020	.045	.079	.122	.174	.236
			Noise Criteria	<15	<15	15	23	30	35	40
			Throw	2-3-10	7-9-19	9-14-24	12-19-28	15-22-31	18-24-34	21-26-36
		4 Ft.	Airflow, CFM	100	180	260	340	420	500	580
			Total Pressure	.011	.036	.075	.128	.196	.278	.373
			Static Pressure	.009	.029	.060	.103	.156	.221	.299
			Noise Criteria	<15	<15	17	24	31	37	42
			Throw	2-4-13	7-12-23	11-17-30	14-22-34	18-28-39	22-30-42	25-32-45
		5 Ft.	Airflow, CFM	110	210	310	410	510	610	710
			Total Pressure	.011	.040	.087	.152	.235	.337	.456
			Static Pressure	.009	.030	.065	.114	.177	.256	.342
			Noise Criteria	<15	<15	17	26	33	39	44
			Throw	1-3-12	6-12-24	12-18-32	15-23-37	20-29-41	23-32-45	28-34-48
1" Slot Width	1 Slot 12" Oval Inlet	2 Ft.	Airflow, CFM	50	95	140	185	230	275	320
			Total Pressure	.004	.017	.037	.064	.100	.142	.194
			Static Pressure	.004	.016	.035	.061	.094	.135	.182
			Noise Criteria	<15	<15	<15	20	27	32	37
			Throw	2-3-10	7-9-19	9-14-24	12-19-28	15-22-31	18-24-34	21-26-36
		4 Ft.	Airflow, CFM	100	190	280	370	460	550	640
			Total Pressure	.009	.032	.068	.120	.185	.264	.358
			Static Pressure	.007	.028	.060	.105	.163	.232	.315
			Noise Criteria	<15	<15	18	26	33	38	43
			Throw	2-4-13	7-12-24	12-18-31	17-24-36	20-29-41	24-31-44	28-33-47
		5 Ft.	Airflow, CFM	110	220	330	440	550	660	770
			Total Pressure	.007	.016	.035	.061	.094	.135	.182
			Static Pressure	.006	.026	.057	.101	.157	.227	.308
			Noise Criteria	<15	<15	17	24	31	37	42
			Throw	1-3-12	7-12-25	12-19-33	17-25-39	21-31-43	25-33-47	30-36-51
1.5" Slot Width	1 Slot 8" Dia. Inlet	2 Ft.	Airflow, CFM	60	110	160	210	260	310	360
			Total Pressure	.009	.029	.060	.104	.159	.226	.305
			Static Pressure	.006	.021	.046	.079	.122	.173	.234
			Noise Criteria	<15	<15	<15	20	27	33	38
			Throw	1-2-9	4-9-18	9-12-24	11-17-29	13-20-32	17-24-34	19-26-37
		4 Ft.	Airflow, CFM	120	200	280	360	440	520	600
			Total Pressure	.020	.057	.111	.184	.276	.385	.513
			Static Pressure	.013	.035	.068	.113	.170	.236	.316
			Noise Criteria	<15	<15	19	27	33	39	43
			Throw	1-3-12	3-9-21	8-14-29	12-19-34	15-23-37	18-26-41	21-31-44
		5 Ft.	Airflow, CFM	140	220	300	380	460	540	620
			Total Pressure	.026	.062	.116	.186	.272	.376	.494
			Static Pressure	.015	.035	.066	.107	.156	.215	.285
			Noise Criteria	<15	<15	19	26	32	38	42
			Throw	1-3-12	3-8-20	6-13-28	10-18-34	14-21-37	17-24-41	19-29-43

For performance table notes, see page A44.

**PERFORMANCE DATA • VERTICAL JET THROW SERIES**

**MODELS: FLV / FTV (15 & 20) • 1 SLOT WITH NAILOR PLENUM**

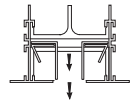

**A**

**FLOWLINE™ LINEAR DIFFUSERS**

1.5" Slot Width	1 Slot 10" Oval Inlet	2 Ft.	Airflow, CFM	60	125	190	255	320	385	450
			Total Pressure	.005	.025	.057	.103	.163	.235	.321
			Static Pressure	.005	.021	.049	.089	.139	.201	.275
			Noise Criteria	<15	<15	<15	23	30	36	41
			Throw	1-2-9	6-10-20	10-14-26	13-20-31	17-24-35	20-28-39	23-30-39
		4 Ft.	Airflow, CFM	120	240	360	480	600	720	840
			Total Pressure	.012	.045	.102	.181	.281	.406	.552
			Static Pressure	.009	.032	.073	.128	.201	.290	.394
			Noise Criteria	<15	<15	19	28	35	41	46
			Throw	1-3-12	6-12-24	12-19-34	17-24-40	21-31-44	24-34-48	29-36-52
		5 Ft.	Airflow, CFM	140	280	420	560	700	840	980
			Total Pressure	.014	.054	.121	.215	.336	.484	.659
			Static Pressure	.009	.036	.081	.144	.226	.325	.443
			Noise Criteria	<15	<15	21	30	37	43	48
			Throw	1-3-12	6-12-25	12-19-35	17-25-41	21-32-46	25-35-51	30-39-54
1.5" Slot Width	1 Slot 12" Oval Inlet	2 Ft.	Airflow, CFM	60	125	190	255	320	385	450
			Total Pressure	.004	.019	.044	.078	.123	.179	.244
			Static Pressure	.004	.017	.040	.072	.112	.163	.221
			Noise Criteria	<15	<15	<15	20	28	34	39
			Throw	1-2-9	6-10-20	10-14-26	13-20-31	17-24-35	20-28-39	23-30-42
		4 Ft.	Airflow, CFM	120	240	360	480	600	720	840
			Total Pressure	.007	.031	.070	.123	.192	.276	.376
			Static Pressure	.006	.025	.055	.097	.153	.220	.300
			Noise Criteria	<15	<15	16	24	31	37	42
			Throw	1-3-12	6-12-24	12-19-34	17-24-40	21-31-44	24-34-48	29-36-52
		5 Ft.	Airflow, CFM	140	280	420	560	700	840	980
			Total Pressure	.009	.035	.079	.141	.220	.318	.432
			Static Pressure	.006	.027	.060	.107	.168	.242	.328
			Noise Criteria	<15	<15	16	25	32	38	43
			Throw	1-3-12	6-12-15	12-19-35	17-25-41	21-32-46	25-35-51	30-39-54
2" Slot Width	1 Slot 8" Dia. Inlet	2 Ft.	Airflow, CFM	70	140	210	280	350	420	490
			Total Pressure	.010	.036	.082	.146	.228	.328	.447
			Static Pressure	.006	.026	.058	.103	.161	.232	.316
			Noise Criteria	<15	<15	16	24	32	38	42
			Throw	1-2-7	3-7-14	7-11-21	9-14-25	12-18-27	14-21-30	17-23-32
		4 Ft.	Airflow, CFM	140	220	300	380	460	540	620
			Total Pressure	.025	.060	.111	.178	.261	.36	.474
			Static Pressure	.014	.033	.062	.098	.144	.200	.263
			Noise Criteria	<15	<15	18	25	31	37	41
			Throw	1-2-8	3-5-14	4-9-20	7-13-26	9-15-29	12-18-31	14-21-33
		5 Ft.	Airflow, CFM	150	250	350	450	550	650	750
			Total Pressure	.026	.071	.138	.227	.339	.474	.631
			Static Pressure	.013	.036	.071	.117	.174	.243	.323
			Noise Criteria	<15	<15	21	29	35	41	45
			Throw	1-2-6	2-4-14	3-9-20	6-14-26	9-16-31	13-20-33	14-22-36
2" Slot Width	1 Slot 10" Oval Inlet	2 Ft.	Airflow, CFM	70	150	230	310	390	470	550
			Total Pressure	.005	.027	.062	.112	.179	.259	.354
			Static Pressure	.004	.021	.050	.091	.144	.210	.287
			Noise Criteria	<15	<15	<15	23	30	36	41
			Throw	1-2-7	3-8-15	8-12-22	10-16-26	14-20-29	16-22-31	19-24-34
		4 Ft.	Airflow, CFM	140	265	390	515	640	765	890
			Total Pressure	.013	.047	.103	.179	.276	.394	.534
			Static Pressure	.009	.031	.068	.119	.184	.263	.356
			Noise Criteria	<15	<15	18	27	34	40	45
			Throw	1-2-8	3-7-18	7-13-26	12-17-31	14-21-34	17-26-37	20-28-40
		5 Ft.	Airflow, CFM	150	300	450	600	750	900	1050
			Total Pressure	.013	.054	.122	.212	.331	.477	.649
			Static Pressure	.009	.033	.074	.132	.205	.295	.401
			Noise Criteria	<15	<15	20	29	36	42	47
			Throw	1-2-6	3-6-18	6-14-26	11-18-31	14-22-36	18-26-39	20-30-42

For performance table notes, see page A44.

PERFORMANCE DATA • VERTICAL JET THROW SERIES

MODELS: FLV / FTV (20, 25 & 30) • 1 SLOT WITH NAILOR PLENUM

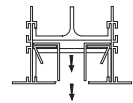

FLOWLINE™ LINEAR DIFFUSERS

Slot Width	Inlet	Throw	Airflow, CFM							
			70	160	250	340	430	520	610	
2" Slot Width	1 Slot 12" Oval Inlet	2 Ft.	Airflow, CFM	70	160	250	340	430	520	610
			Total Pressure	.004	.022	.055	.102	.162	.236	.325
			Static Pressure	.004	.019	.048	.089	.141	.208	.286
			Noise Criteria	<15	<15	<15	23	30	37	42
	Throw			1-2-7	4-9-16	9-13-23	12-17-27	14-21-30	18-24-33	20-26-36
	4 Ft.	Airflow, CFM	140	290	440	590	740	890	1040	
		Total Pressure	.009	.035	.082	.148	.232	.335	.458	
		Static Pressure	.006	.027	.061	.109	.172	.249	.340	
		Noise Criteria	<15	<15	16	26	33	39	44	
	Throw			1-2-8	3-9-20	9-14-28	14-20-32	16-25-37	20-28-40	23-31-43
	5 Ft.	Airflow, CFM	150	330	510	690	870	1050	1230	
		Total Pressure	.009	.040	.096	.175	.279	.406	.557	
Static Pressure		.005	.028	.067	.124	.197	.289	.394		
Noise Criteria		<15	<15	18	28	35	41	46		
Throw			1-2-6	3-8-20	8-15-29	14-20-34	17-26-38	20-30-42	25-32-46	
2.5" Slot Width	1 Slot 12" Oval Inlet	2 Ft.	Airflow, CFM	80	190	300	410	520	630	740
			Total Pressure	.004	.025	.061	.114	.185	.271	.375
			Static Pressure	.003	.020	.051	.096	.155	.228	.315
			Noise Criteria	<15	<15	<15	24	31	38	43
	Throw			1-2-6	4-9-17	9-14-25	12-19-29	15-23-32	19-26-36	22-27-38
	4 Ft.	Airflow, CFM	150	335	520	705	890	1075	1260	
		Total Pressure	.009	.042	.100	.183	.292	.426	.584	
		Static Pressure	.005	.029	.071	.129	.207	.301	.413	
		Noise Criteria	<15	<15	19	28	36	42	47	
	Throw			1-2-6	3-8-20	9-15-30	14-21-35	18-26-39	21-30-43	25-32-46
	5 Ft.	Airflow, CFM	160	370	580	790	1000	1210	1420	
		Total Pressure	.009	.044	.108	.200	.320	.469	.646	
Static Pressure		.005	.029	.072	.133	.212	.310	.428		
Noise Criteria		<15	<15	19	29	37	43	48		
Throw			1-1-5	3-7-20	7-15-31	14-20-36	17-26-40	21-31-44	25-34-48	
3" Slot Width	1 Slot 14" Oval Inlet	2 Ft.	Airflow, CFM	100	225	350	475	600	725	850
			Total Pressure	.004	.022	.055	.102	.162	.236	.325
			Static Pressure	.004	.020	.048	.088	.141	.205	.282
			Noise Criteria	<15	<15	<15	22	30	36	41
	Throw			1-2-7	4-9-18	9-14-26	13-20-31	16-24-34	20-26-37	23-29-40
	4 Ft.	Airflow, CFM	200	400	600	800	1000	1200	1400	
		Total Pressure	.010	.036	.082	.146	.228	.328	.446	
		Static Pressure	.006	.027	.061	.108	.169	.244	.333	
		Noise Criteria	<15	<15	<15	26	33	39	44	
	Throw			1-2-8	3-8-21	8-16-31	14-21-36	18-26-40	21-31-44	25-33-48
	5 Ft.	Airflow, CFM	240	460	680	900	1120	1340	1560	
		Total Pressure	.012	.042	.091	.159	.247	.354	.480	
Static Pressure		.007	.030	.064	.112	.174	.249	.338		
Noise Criteria		<15	<15	18	27	34	49	44		
Throw			1-2-8	3-8-21	7-16-32	13-21-37	18-26-42	21-31-45	25-35-48	

Performance Notes:

1. Data is based upon FlowLine™ with Nailor engineered plenum (uninsulated) as a complete assembly.
2. All pressures are in inches w.g..
3. Throw values are given at 150, 100 and 50 fpm terminal velocities under isothermal conditions.
4. Noise criteria values are based on 10 dB room absorption, re 10<sup>-12</sup> watts.
5. Throw values are based on pattern controller set 100% open.
6. Data derived from tests conducted in accordance with ANSI/ASHRAE Standard 70-2006.

**PERFORMANCE DATA • VERTICAL JET THROW SERIES**

**MODELS: FLV / FTV (10 & 15) • 2 SLOT WITH NAILOR PLENUM**

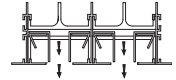

**A**

**FLOWLINE™ LINEAR DIFFUSERS**

<b>1" Slot Width</b>	<b>2 Slot 8" Dia. Inlet</b>	<b>2 Ft.</b>	Airflow, CFM	<b>80</b>	<b>155</b>	<b>230</b>	<b>305</b>	<b>380</b>	<b>455</b>	<b>530</b>
			Total Pressure	.012	.045	.098	.173	.269	.385	.523
			Static Pressure	.009	.032	.070	.122	.189	.272	.369
			Noise Criteria	<15	<15	18	27	34	40	45
			Throw	2-4-13	7-12-23	12-19-29	12-23-33	21-26-36	23-29-40	25-31-43
		<b>4 Ft.</b>	Airflow, CFM	<b>160</b>	<b>260</b>	<b>360</b>	<b>460</b>	<b>560</b>	<b>660</b>	<b>760</b>
			Total Pressure	.031	.083	.159	.261	.386	.537	.712
			Static Pressure	.017	.046	.089	.144	.215	.299	.396
			Noise Criteria	<15	<15	24	31	38	43	48
			Throw	2-4-17	6-12-28	10-29-33	17-24-37	20-29-41	23-31-44	26-34-47
		<b>5 Ft.</b>	Airflow, CFM	<b>200</b>	<b>300</b>	<b>400</b>	<b>500</b>	<b>600</b>	<b>700</b>	<b>800</b>
			Total Pressure	.045	.101	.180	.280	.404	.550	.718
			Static Pressure	.022	.051	.092	.143	.207	.281	.368
			Noise Criteria	<15	<15	25	32	38	43	47
			Throw	2-4-19	4-11-19	9-19-34	13-23-37	19-29-41	22-32-44	25-34-47
<b>1" Slot Width</b>	<b>2 Slot 10" Dia. Inlet</b>	<b>2 Ft.</b>	Airflow, CFM	<b>80</b>	<b>165</b>	<b>250</b>	<b>335</b>	<b>420</b>	<b>505</b>	<b>590</b>
			Total Pressure	.006	.029	.067	.121	.190	.275	.376
			Static Pressure	.005	.024	.054	.096	.151	.217	.297
			Noise Criteria	<15	<15	<15	23	31	37	42
			Throw	2-4-13	8-13-24	13-20-30	18-24-34	22-28-39	24-30-42	26-32-46
		<b>4 Ft.</b>	Airflow, CFM	<b>160</b>	<b>300</b>	<b>440</b>	<b>580</b>	<b>720</b>	<b>860</b>	<b>1000</b>
			Total Pressure	.016	.057	.122	.212	.326	.464	.628
			Static Pressure	.011	.036	.078	.136	.210	.299	.404
			Noise Criteria	<15	<15	20	29	36	42	47
			Throw	2-4-17	7-15-30	15-23-36	21-30-42	25-33-46	30-35-51	32-39-55
		<b>5 Ft.</b>	Airflow, CFM	<b>200</b>	<b>350</b>	<b>500</b>	<b>650</b>	<b>800</b>	<b>950</b>	<b>1100</b>
			Total Pressure	.022	.068	.140	.238	.360	.506	.679
			Static Pressure	.014	.042	.085	.142	.215	.304	.408
			Noise Criteria	<15	<15	22	31	37	43	47
			Throw	2-4-19	7-14-32	13-23-37	20-31-43	25-43-47	30-36-52	32-40-56
<b>1" Slot Width</b>	<b>2 Slot 12" Dia. Inlet</b>	<b>2 Ft.</b>	Airflow, CFM	<b>80</b>	<b>170</b>	<b>260</b>	<b>350</b>	<b>440</b>	<b>530</b>	<b>620</b>
			Total Pressure	.004	.021	.049	.090	.142	.207	.282
			Static Pressure	.004	.018	.043	.077	.122	.177	.242
			Noise Criteria	<15	<15	<15	21	28	34	39
			Throw	2-4-13	8-13-24	14-21-31	19-25-35	23-28-40	25-31-43	28-33-47
		<b>4 Ft.</b>	Airflow, CFM	<b>160</b>	<b>320</b>	<b>480</b>	<b>640</b>	<b>800</b>	<b>960</b>	<b>1120</b>
			Total Pressure	.010	.036	.082	.147	.229	.330	.448
			Static Pressure	.006	.026	.058	.102	.159	.229	.312
			Noise Criteria	<15	<15	<15	24	32	37	42
			Throw	2-4-17	8-17-31	17-25-37	23-31-44	29-34-48	31-37-54	33-41-57
		<b>5 Ft.</b>	Airflow, CFM	<b>200</b>	<b>375</b>	<b>550</b>	<b>725</b>	<b>900</b>	<b>1075</b>	<b>1250</b>
			Total Pressure	.013	.044	.095	.165	.255	.363	.490
			Static Pressure	.009	.029	.062	.108	.167	.238	.321
			Noise Criteria	<15	<15	17	26	33	38	43
			Throw	2-4-19	8-17-33	17-25-40	23-32-45	29-35-51	32-39-55	34-42-59
<b>1.5" Slot Width</b>	<b>2 Slot 10" Dia. Inlet</b>	<b>2 Ft.</b>	Airflow, CFM	<b>120</b>	<b>210</b>	<b>300</b>	<b>390</b>	<b>480</b>	<b>570</b>	<b>660</b>
			Total Pressure	.011	.033	.068	.116	.175	.248	.333
			Static Pressure	.007	.024	.048	.082	.124	.175	.234
			Noise Criteria	<15	<15	<15	21	27	33	38
			Throw	2-4-15	6-13-26	12-19-31	17-25-35	21-28-40	24-31-43	26-33-46
		<b>4 Ft.</b>	Airflow, CFM	<b>240</b>	<b>340</b>	<b>440</b>	<b>540</b>	<b>640</b>	<b>740</b>	<b>840</b>
			Total Pressure	.029	.059	.097	.148	.207	.276	.356
			Static Pressure	.016	.032	.055	.082	.114	.154	.198
			Noise Criteria	<15	<15	<15	22	28	32	37
			Throw	2-6-20	4-10-29	8-17-34	11-23-39	15-26-42	21-31-45	23-34-47
		<b>5 Ft.</b>	Airflow, CFM	<b>260</b>	<b>365</b>	<b>470</b>	<b>575</b>	<b>680</b>	<b>785</b>	<b>890</b>
			Total Pressure	.031	.061	.102	.152	.213	.284	.365
			Static Pressure	.016	.031	.052	.078	.109	.146	.187
			Noise Criteria	<15	<15	<15	22	28	32	36
			Throw	2-4-17	3-8-28	6-13-35	9-20-39	12-25-42	17-30-45	21-33-47

For performance table notes, see page A47.



PERFORMANCE DATA • VERTICAL JET THROW SERIES

MODELS: FLV / FTV (15 & 20) • 2 SLOT WITH NAILOR PLENUM

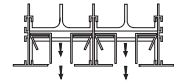

FLOWLINE™ LINEAR DIFFUSERS

1.5" Slot Width	2 Slot 12" Dia. Inlet	2 Ft.	Airflow, CFM	120	230	340	450	560	670	780
			Total Pressure	.006	.025	.054	.094	.146	.209	.284
			Static Pressure	.005	.019	.042	.073	.112	.161	.217
			Noise Criteria	<15	<15	<15	19	26	32	36
		Throw	2-4-15	8-14-28	14-22-33	19-26-39	24-30-43	26-33-46	29-35-40	
		4 Ft.	Airflow, CFM	240	390	540	690	840	990	1140
			Total Pressure	.016	.043	.082	.134	.199	.276	.366
			Static Pressure	.010	.027	.050	.082	.122	.170	.225
			Noise Criteria	<15	<15	<15	22	28	33	38
		Throw	2-6-20	6-13-32	17-25-37	23-31-44	29-34-48	31-37-54	33-41-57	
		5 Ft.	Airflow, CFM	260	425	590	755	920	1085	1250
			Total Pressure	.017	.046	.089	.144	.215	.300	.397
Static Pressure	.010		.027	.051	.083	.124	.172	.228		
Noise Criteria	<15		<15	<15	22	29	34	39		
Throw	2-4-17	4-11-32	9-21-39	15-29-44	22-34-48	26-37-53	31-40-56			
1.5" Slot Width	2 Slot 14" Dia. Inlet	2 Ft.	Airflow, CFM	120	240	360	480	600	720	840
			Total Pressure	.005	.018	.042	.074	.116	.167	.227
			Static Pressure	.004	.015	.034	.061	.094	.136	.185
			Noise Criteria	<15	<15	<15	<15	23	29	34
		Throw	2-4-15	8-15-28	15-23-34	21-28-40	25-31-44	28-34-48	30-36-52	
		4 Ft.	Airflow, CFM	240	415	590	765	940	1115	1290
			Total Pressure	.010	.030	.060	.101	.152	.214	.287
			Static Pressure	.006	.019	.040	.066	.101	.141	.189
			Noise Criteria	<15	<15	<15	18	24	30	35
		Throw	2-6-20	7-15-33	13-25-40	22-32-45	26-35-51	31-39-55	34-42-55	
		5 Ft.	Airflow, CFM	260	440	620	800	980	1160	1340
			Total Pressure	.011	.032	.063	.105	.157	.220	.293
Static Pressure	.007		.020	.041	.067	.101	.141	.188		
Noise Criteria	<15		<15	<15	18	25	30	35		
Throw	2-4-17	6-12-33	10-23-40	17-30-45	24-35-51	29-39-55	33-42-58			
2" Slot Width	2 Slot 10" Dia. Inlet	2 Ft.	Airflow, CFM	70	140	210	280	350	420	490
			Total Pressure	.003	.013	.028	.050	.078	.112	.154
			Static Pressure	.002	.009	.018	.032	.051	.073	.100
			Noise Criteria	<15	<15	<15	<15	<15	19	24
		Throw	0-1-3	1-3-11	3-6-18	5-11-22	8-14-25	11-18-27	14-20-30	
		4 Ft.	Airflow, CFM	250	355	460	565	670	775	880
			Total Pressure	.028	.057	.095	.143	.201	.270	.348
			Static Pressure	.014	.028	.047	.072	.101	.135	.174
			Noise Criteria	<15	<15	<15	21	27	31	35
		Throw	1-3-10	3-5-20	4-9-26	6-13-29	9-19-31	11-21-34	14-25-37	
		5 Ft.	Airflow, CFM	280	390	500	610	720	830	940
			Total Pressure	.032	.061	.101	.150	.210	.278	.357
Static Pressure	.014		.027	.045	.067	.093	.128	.158		
Noise Criteria	<15		<15	<15	21	27	31	35		
Throw	1-3-9	2-4-17	3-7-25	4-10-30	7-14-32	9-20-34	11-23-37			
2" Slot Width	2 Slot 12" Dia. Inlet	2 Ft.	Airflow, CFM	140	275	410	545	680	815	950
			Total Pressure	.007	.028	.062	.109	.170	.244	.332
			Static Pressure	.005	.019	.044	.077	.120	.172	.234
			Noise Criteria	<15	<15	<15	20	27	33	38
		Throw	1-3-11	5-11-22	11-17-27	15-22-31	19-25-35	22-27-38	24-27-38	
		4 Ft.	Airflow, CFM	250	425	600	775	950	1125	1300
			Total Pressure	.015	.044	.088	.147	.219	.308	.412
			Static Pressure	.008	.024	.049	.081	.122	.171	.229
			Noise Criteria	<15	<15	<15	22	29	34	39
		Throw	1-3-10	3-8-24	7-14-30	11-21-34	16-26-37	20-29-41	24-31-44	
		5 Ft.	Airflow, CFM	280	460	640	820	1000	1180	1360
			Total Pressure	.017	.047	.091	.149	.221	.309	.410
Static Pressure	.008		.024	.047	.076	.113	.158	.210		
Noise Criteria	<15		<15	<15	22	28	34	38		
Throw	1-3-9	3-6-22	5-12-31	9-19-34	13-25-37	18-29-41	22-31-44			

For performance table notes, see page A47.

**PERFORMANCE DATA • VERTICAL JET THROW SERIES**

**MODELS: FLV / FTV (20, 25 & 30) • 2 SLOT WITH NAILOR PLENUM**

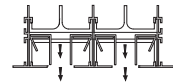

**A**

**FLOWLINE™ LINEAR DIFFUSERS**

<b>2" Slot Width</b>	<b>2 Slot 14" Dia. Inlet</b>	<b>2 Ft.</b>	Airflow, CFM	140	280	420	560	700	840	980
			Total Pressure	.004	.018	.041	.073	.114	.165	.225
			Static Pressure	.003	.014	.031	.055	.086	.123	.168
			Noise Criteria	<15	<15	<15	<15	21	27	32
			Throw	1-3-11	5-11-22	11-18-27	15-22-31	20-25-36	22-27-39	24-30-42
		<b>4 Ft.</b>	Airflow, CFM	250	450	650	850	1050	1250	1450
			Total Pressure	.010	.030	.062	.106	.161	.228	.307
			Static Pressure	.005	.018	.037	.063	.096	.137	.184
			Noise Criteria	<15	<15	<15	18	24	30	35
			Throw	1-3-10	3-9-25	8-17-31	13-24-36	20-28-40	23-31-43	26-33-47
		<b>5 Ft.</b>	Airflow, CFM	280	480	680	880	1080	1280	1480
			Total Pressure	.011	.030	.061	.102	.153	.215	.288
			Static Pressure	.005	.017	.034	.057	.086	.120	.159
			Noise Criteria	<15	<15	<15	16	23	28	33
			Throw	1-3-10	3-8-28	7-15-37	11-25-42	17-31-46	24-26-50	28-38-54
<b>2.5" Slot Width</b>	<b>2 Slot 14" Dia. Inlet</b>	<b>2 Ft.</b>	Airflow, CFM	150	335	520	705	890	1075	1260
			Total Pressure	.004	.022	.054	.098	.157	.229	.315
			Static Pressure	.003	.016	.037	.070	.111	.162	.223
			Noise Criteria	<15	<15	<15	18	26	32	37
			Throw	1-3-9	5-11-24	12-20-30	17-25-35	22-27-39	25-31-43	26-32-46
		<b>4 Ft.</b>	Airflow, CFM	300	540	780	1020	1260	1500	1740
			Total Pressure	.012	.039	.080	.137	.209	.295	.398
			Static Pressure	.006	.021	.044	.076	.116	.164	.220
			Noise Criteria	<15	<15	<15	21	28	33	38
			Throw	1-3-10	3-9-26	8-17-33	13-25-38	20-30-43	25-32-46	28-35-50
		<b>5 Ft.</b>	Airflow, CFM	350	600	850	1100	1350	1600	1850
			Total Pressure	.015	.043	.087	.144	.218	.306	.410
			Static Pressure	.007	.022	.044	.074	.111	.157	.210
			Noise Criteria	<15	<15	<15	22	28	34	38
			Throw	1-3-9	3-7-26	6-14-34	10-23-38	15-29-43	22-33-47	26-36-50
<b>3" Slot Width</b>	<b>2 Slot 14" Dia. Inlet</b>	<b>2 Ft.</b>	Airflow, CFM	175	385	595	805	1015	1225	1435
			Total Pressure	.005	.026	.062	.113	.181	.263	.361
			Static Pressure	.003	.017	.042	.076	.120	.175	.241
			Noise Criteria	<15	<15	<15	20	27	33	38
			Throw	1-3-9	5-10-25	11-20-31	18-26-37	22-29-41	26-31-44	28-34-18
		<b>4 Ft.</b>	Airflow, CFM	320	580	840	1100	1360	1620	1880
			Total Pressure	.013	.042	.087	.149	.227	.322	.433
			Static Pressure	.006	.021	.045	.078	.119	.168	.227
			Noise Criteria	<15	<15	<15	22	27	34	39
			Throw	1-2-9	3-7-26	7-14-34	11-24-39	17-30-43	24-33-47	27-36-51
		<b>5 Ft.</b>	Airflow, CFM	380	645	910	1175	1440	1705	1970
			Total Pressure	.016	.045	.090	.149	.224	.314	.419
			Static Pressure	.007	.020	.041	.068	.103	.144	.193
			Noise Criteria	<15	<15	<15	21	28	33	38
			Throw	1-2-9	3-6-23	5-12-34	9-20-39	13-28-43	18-33-47	24-36-50

**Performance Notes:**

1. Data is based upon FlowLine™ with Nailor engineered plenum (uninsulated) as a complete assembly.
2. All pressures are in inches w.g..
3. Throw values are given at 150, 100 and 50 fpm terminal velocities under isothermal conditions.
4. Noise criteria values are based on 10 dB room absorption, re 10<sup>-12</sup> watts.
5. Throw values are based on pattern controller set 100% open.
6. Data derived from tests conducted in accordance with ANSI/ASHRAE Standard 70-2006.

# INSTALLATION, OPERATION & MAINTENANCE

M  
A  
N  
U  
A  
L

## Flowline™

### Architectural Linear Diffusers



FLH Series: Horizontal High Throw  
FLV Series: Vertical Jet Throw  
[www.nailor.com](http://www.nailor.com)

 **Nailor**<sup>®</sup>  
Industries Inc.

## Installation Practices During Hard Ceiling Construction

Following are the recommended instructions for Flowline™ Diffuser installation. It is the responsibility of the installing contractor to install in accordance with local codes and regulations.

### Summary of Steps to Install Flowline™ in Hard Ceiling Applications

- Step 1. Determine Diffuser Frame/Border Style
- Step 2. Construct Ceiling Framework
- Step 3. Install Ceiling/Wall Clips on Diffuser
- Step 4. Fasten Diffuser to Ceiling Framework
- Step 5. Insert Drywall According to Frame/Border Style
- Step 6. Attach Plenum to Diffuser (if required)
- Step 7. Installation without plenum
- Step 8. Surface Finishing Procedure (where applicable)

### 1. Identify the Flowline Diffuser Frame Style for your installation.

There are six frame/border styles described below and most can combine with each other to accommodate any application.

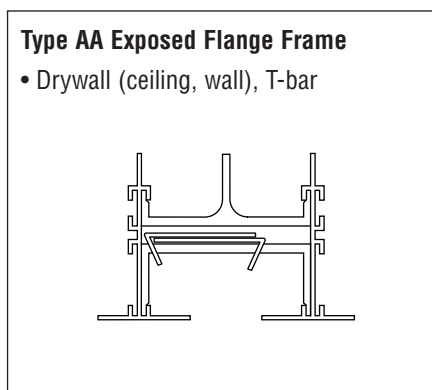

**Figure 1. Frame style A.**

Frame border style A - used for hard ceiling applications and T-bar systems. Available with concealed mounting brackets (Type AAC)

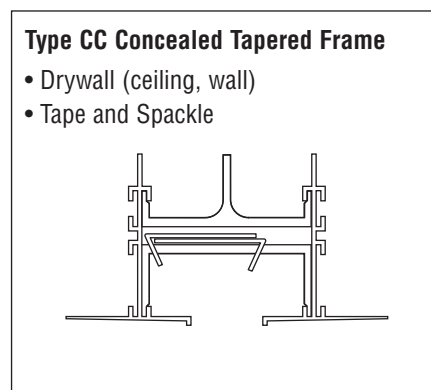

**Figure 2. Frame style C.**

Frame border style C - used for hard ceiling applications when the flanges are to be concealed. Available with concealed mounting brackets (Type CCC)

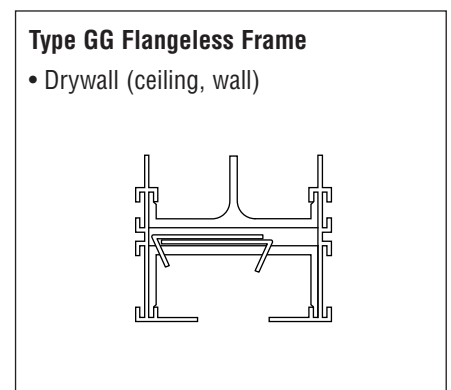

**Figure 3. Frame style G.**

Frame border style G - used for flush mounting in hard ceiling and regressed T-Bar suspension ceiling applications.

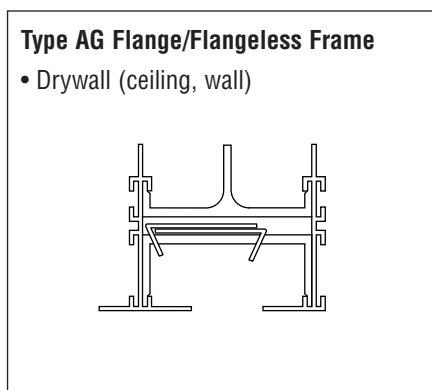

**Figure 4. Frame Style AG.**

Frame border styles A and G - combine to fit hard ceiling and T-Bar applications where a perimeter application is desired.

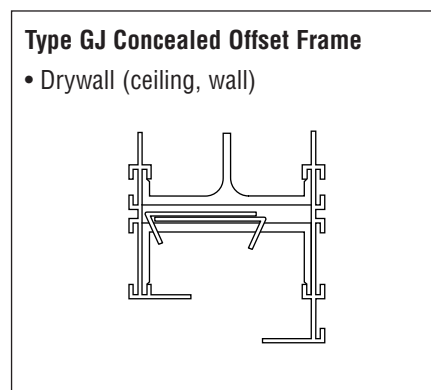

**Figure 5. Frame Style GJ.**

Frame border styles G and J - combine to fit hard ceiling applications in perimeter applications or where the ceiling meets a wall or ceiling height varies.

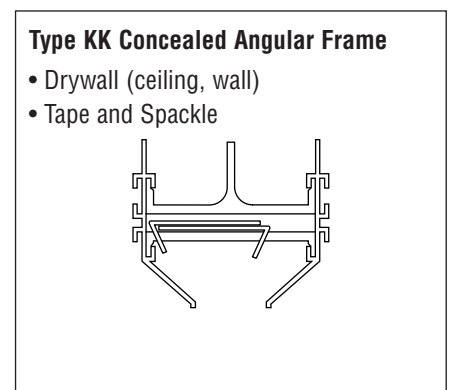

**Figure 6. Frame Style K.**

Frame border style K - the slot is the only visible part of the diffuser in hard ceiling application and drywall is cut at 45 degree angle to be flush with frame.

## 2. Construct Ceiling Framework.

Figure 7 below depicts the recommended installation process to integrate the Flowline™ system into the hard ceiling application which is best achieved if done concurrently with hard ceiling installation.

- Before installing drywall, frame the ceiling in such a way that the selected diffuser frame style fits with enough room to attach an associated plenum onto its top.
- A continuous length of framework is recommended in order to fasten the hard ceiling clips at required spacings.
- The table included in Figure 7 shows the required frame opening width (FW) based on diffuser model and number of slots.
- Make sure framework material is suitable for bearing load applied by diffuser once fastened.
- If there is going to be inadequate spacing to install a plenum onto the diffuser after the diffuser is installed into the hard ceiling, support the plenum above the ceiling framework using integral hanger brackets with wires prior to diffuser installation.

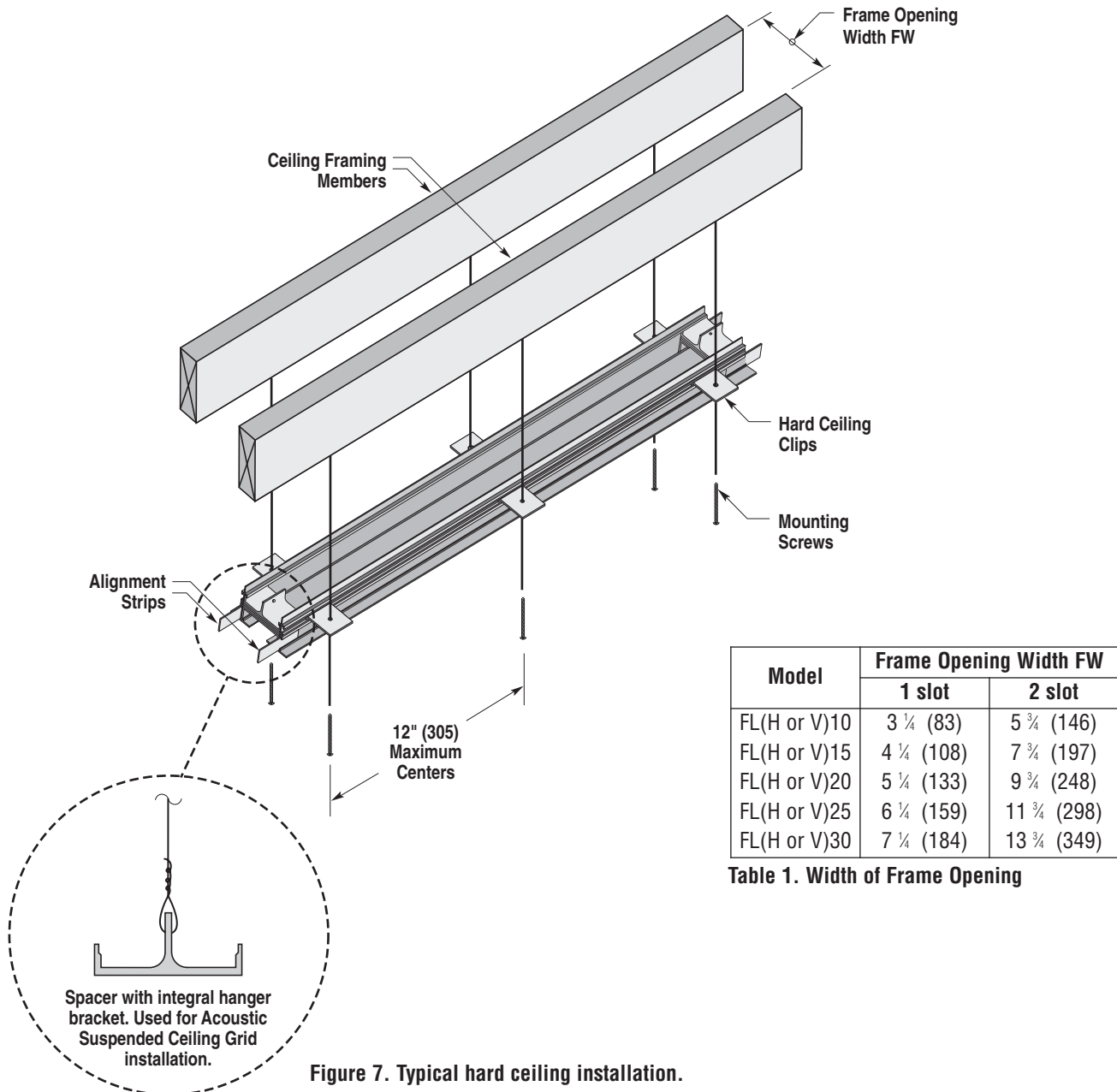

### 3. Install Ceiling/Wall Clips on Diffuser.

- A. For Exposed Flange Frame/Border Style A and Flangeless Flush Frame/Border Styles G and J (See Figure 8).
  - a. Size diffuser if necessary to fit opening (see field cutting procedure on page 11).
  - b. Spacers are factory installed with integral hanger brackets at maximum 24" (610) centers.
  - c. Insert appropriate hard ceiling (HC) clips into the diffuser's lower outside rail niches at maximum 12" (305) centers.
  - d. Insert blank-offs as required
  - e. Install end caps where required.
  - f. Suspend diffuser section at approximate final position and height by attaching to the plenum, if pre-installed, and/or using hanger wire attached to spacers with integral hanger brackets. This is to be repeated for each individual section.
  - g. Use alignment strips to join additional diffuser sections together inline and check ends for flushness.
 

**Note:** Leave a 1/8" (3) gap to allow for thermal expansion between sections longer than 12 feet (3658).
  - h. Go to Step 4 on page 5.

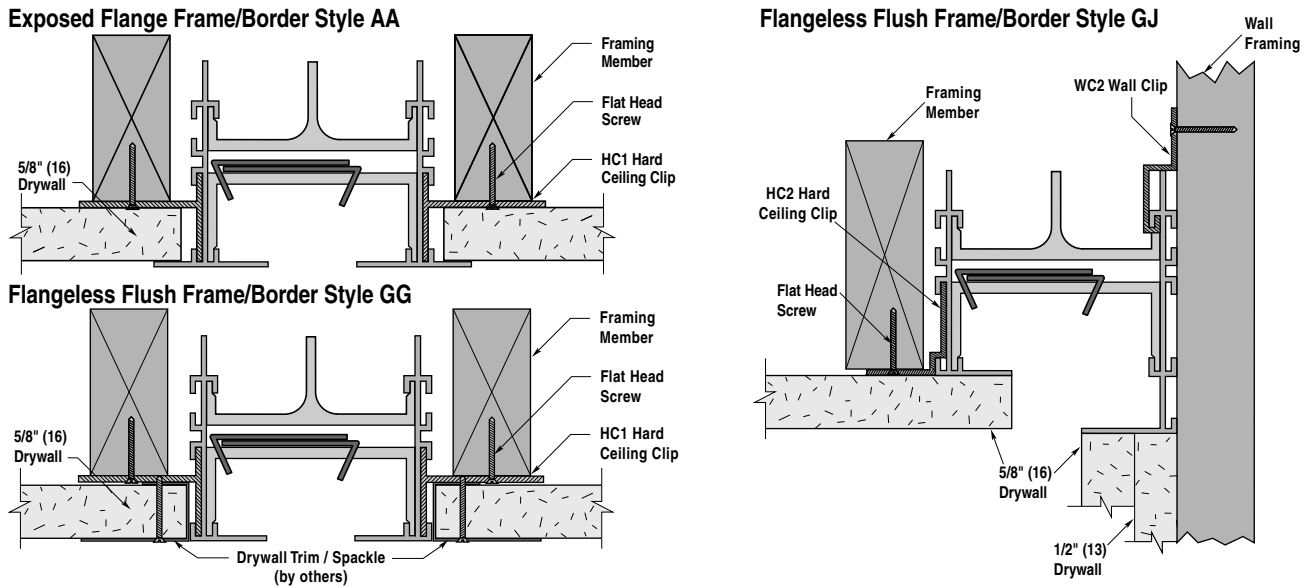

Figure 8. Depictions of frames A, G and J hard ceiling installations.

- B. For Concealed Tapered Frame/Border Styles C and K (see Figure 9).
  - a. Size diffuser as needed to fit opening (see field cutting procedure on page 11).
  - b. Spacers are factory installed with integral hanger brackets at maximum 24" (610) centers.
  - c. Insert appropriate hard ceiling (HC) clips into the diffuser's lower outside rail niches at maximum 12" (305) centers.
  - d. Insert blank-offs as required.
  - e. Install end caps where required.
  - f. Suspend diffuser section at approximate final position and height by attaching to the plenum, if pre-installed, and/or using hanger wire attached to spacers with integral hanger brackets. This is to be repeated for each individual section.
  - g. Use alignment strips to join additional diffuser sections together inline and check ends for flushness.
 

**Note:** Leave a 1/8" (3) gap to allow for thermal expansion between sections longer than 12 feet (3658).
  - h. Go to Step 4A on page 5.

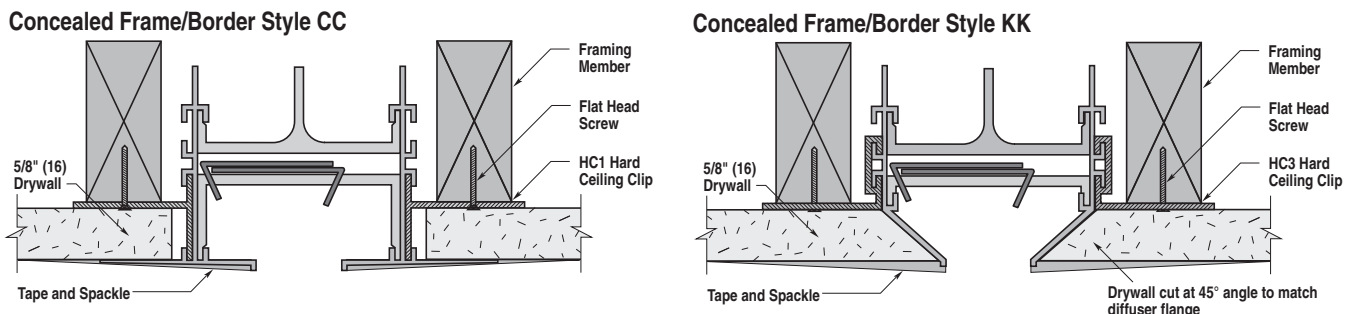

Figure 9. Depictions of frame C and K hard ceiling installations.

#### 4. Fasten Diffuser to Ceiling Framework.

- A. For All Frame/Border Styles except J
  - a. Fasten diffuser sections to framework by drilling 1/2" – 3/4" (13 – 19) flat head screws through **HC** Hard Ceiling Clips into framework at maximum 12" (305) centers (See Figure 8).
  - b. Go to Step 5.
- B. For Frame/Border Style J
  - a. Fasten diffuser sections to wall framing by drilling 1/2" – 3/4" (13 – 19) flat head screws through **WC** Wall Clips into framework at maximum 12" (305) centers.
  - b. Go to Step 5.

#### 5. Insert Drywall According to Frame/Border Style.

**Note:** If diffuser inlet is inaccessible after drywall installation, perform step 6 first, then step 5.

- A. For Frame/Border Style A (See Figure 8)
  - a. Insert correctly sized drywall sheets between Flowline™ flanged border and framework, assuring a snug fit.
- B. For Frame/Border style G and J (See Figure 8)
  - a. Assure drywall is flush with Flowline™ border.
- C. For Frame/Border Style C (See Figure 9)
  - a. Insert correctly sized drywall sheets between Flowline™ border and framework, assuring a snug fit.
  - b. Secure with min. 1 1/4" (32) drywall screws through the drywall and into the ceiling framework just outside tapered border flange at maximum 12" (305) centers.
- D. For Frame/Border Style K (See Figure 9)
  - a. Cut end of drywall at 45 degree angle to fit flush with diffuser border.
  - b. Secure with min. 1 1/4" (32) drywall screws through the drywall and into the ceiling framework outside beveled border at maximum 12" (305) centers.

#### 6. Attach Plenum to Diffuser.

**Note:** Install non-Nailor® engineered plenums using current industry standards.

- A. Nailor® engineered plenums (See Figure 10). Two types:
  - a. Straight leg version with spring clips for direct attachment to diffuser neck. This style is for hard ceiling installations using diffuser ceiling clips prior to drywall installation.
  - b. Hemmed leg version for diffusers with concealed mounting brackets for diffuser installation after drywall installation.

##### Hemmed Leg Plenum

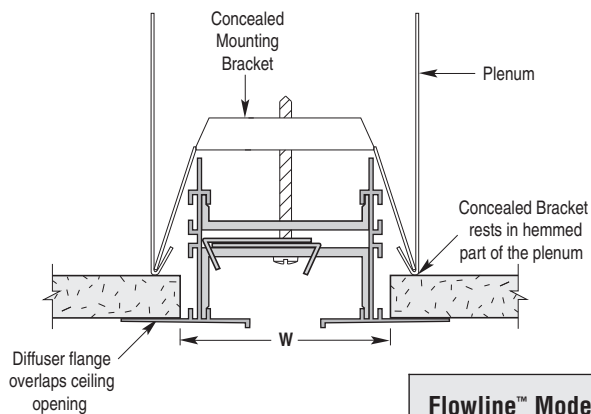

##### Straight Leg Plenum

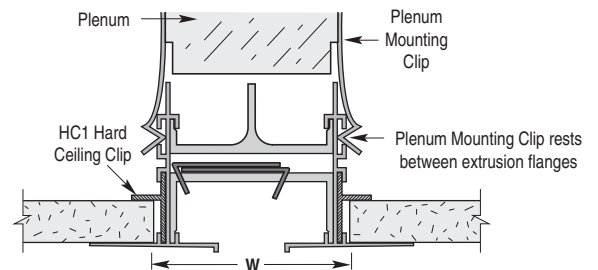

Flowline™ Model	Ceiling Opening Width W	
	1 Slot	2 Slot
FL(H or V)10	3	5 1/2"
FL(H or V)15	4	7 1/2"
FL(H or V)20	5	9 1/2"
FL(H or V)25	6	11 1/2"
FL(H or V)30	7	13 1/2"

**Table 2. Width of Ceiling Opening**

**Figure 10. Installations with Nailor® Engineered Plenums**

- B. Attach hanger wire to plenum seismic tabs and secure to building structure per local code near location of final diffuser installation.
- a. Straight leg plenum:
    - i. Lift plenum into place and attach to the diffuser using spring clips provided.
    - ii. Attach ductwork to plenum inlet collar in accordance with recommended practices.  
(**Note:** If plenum inlet is readily accessible after diffuser installation, this step can be performed later.)
  - b. Hemmed leg plenum:
    - i. Lift and push diffuser section into place until mounting brackets spring into hemmed edge and secure with concealed mounting brackets provided using a flat head screw driver, ensuring diffuser is in correct location.
    - ii. Attach ductwork to plenum inlet collar in accordance with recommended practices.  
(**Note:** If plenum inlet is readily accessible after diffuser installation, this step can be performed later.)
    - iii. Secure diffuser border to drywall with min. 1 1/4" (32) drywall screws on 12" (305) max. centers. (Frame/border style CCC only).
    - iv. Check and re-tighten diffuser to concealed mounting brackets if necessary.

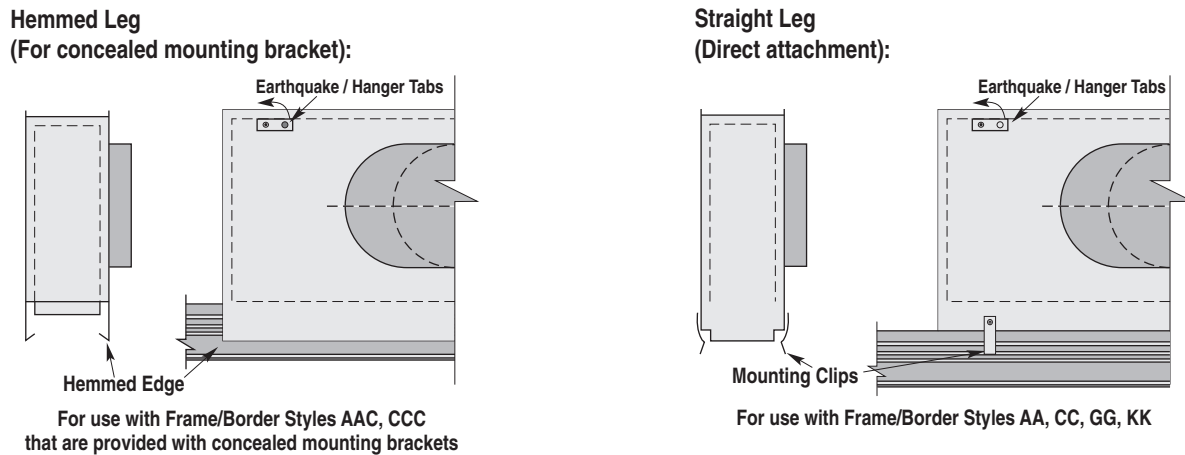

Figure 11. Nailor plenum designs.

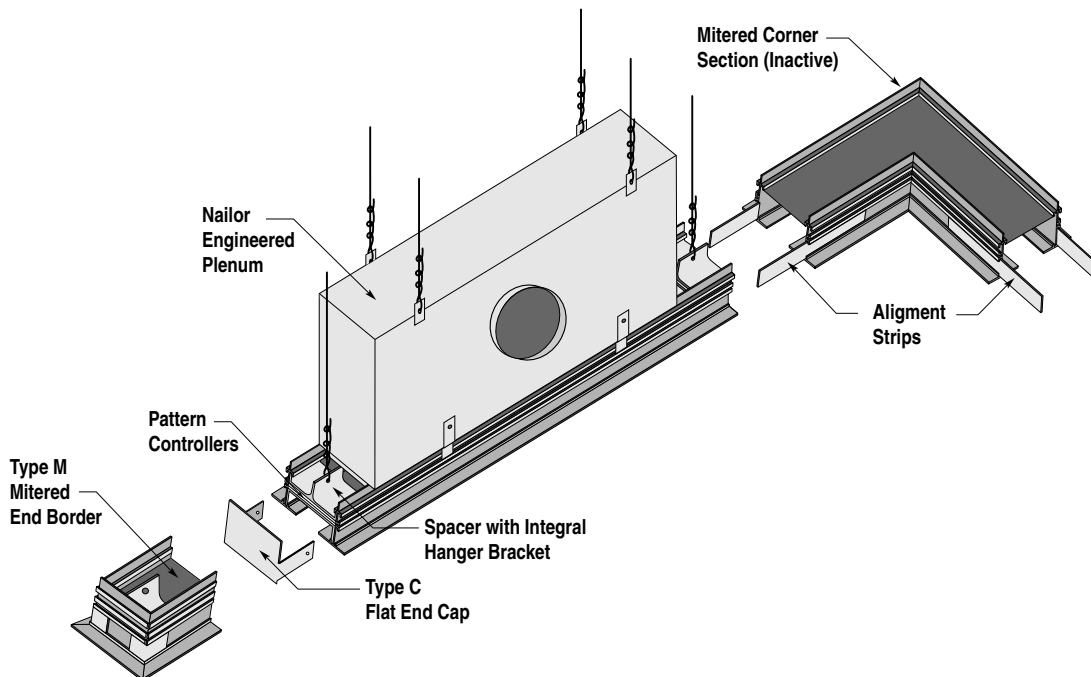

Figure 12. Typical diffuser assembly with mitered fitting installation.



## 7. Installation of Flowline™ without a Plenum or HC Hard Ceiling Clips (See Figure 13)

On continuous diffuser run installations where the diffuser section does not match up with a plenum, the drywall can be used to support the diffuser.

- Lift and push diffuser section with concealed mounting brackets attached through drywall opening. Ensure bracket legs straddle drywall opening.
- Fasten the diffuser to the concealed mounting bracket with a flathead screw driver until the diffuser border is flush with the drywall.
- Secure diffuser border to drywall with min. 1 1/4" (32) drywall screws on 12" (305) max. centers (Frame/Border style CCC only).
- Check and re-tighten diffuser to concealed mounting brackets if necessary.

Exposed Flange Frame/Border Style AAC

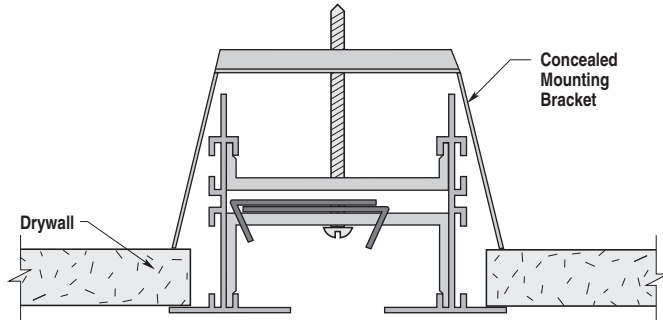

Concealed Frame/Border Style CCC

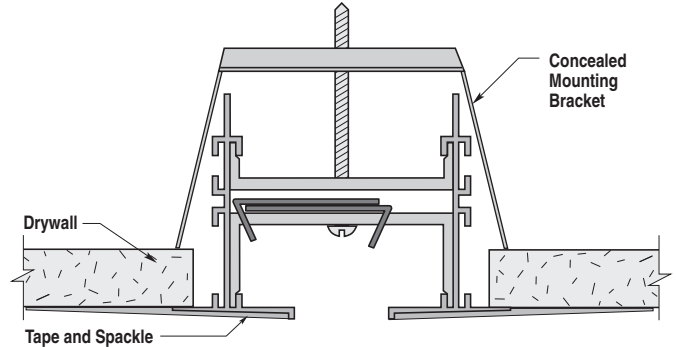

Figure 13. Typical concealed flange frame installation without plenum.

## 8. Surface Finishing Procedure (Frame/Border Styles C and K)

(If Applicable) (See Figure 14)

- Clean and degrease tapered border with cleaner/degreaser (e.g. Pure Strength by Rust-Oleum). Continue to step B.
- Apply a bonding agent (e.g. Plaster Weld by Larsen Products Corp.) to tapered border and allow to dry minimum 1 hour or to manufacturer's instructions.
- Apply a first coat of joint compound (e.g. Durabond by US Gypsum) onto diffuser flange and extend 3" (76) from edge of flange onto drywall. **Tip:** For frame border style K, the majority of the flange is covered by the drywall, so extend compound 4" (102) from edge of exposed flange.
- Embed 4" (102) wide mesh tape into joint compound and add another layer of joint compound atop the mesh tape and smooth. Let dry completely before moving to the next step. **Tip:** Be sure to eliminate all air bubbles from mesh tape and overlap onto drywall to assure best results, but do not extend tape into slot opening of the diffuser.
- Apply minimum two coats of standard finish compound (spackle), letting each dry completely and smooth each coat with fine grit sand paper until flush with drywall. **Tip:** Use wetted sponge for very rough areas of spackle and finish with fine grit sand paper.
- Apply primer to flush finishing compound and paint as scheduled.
- DO NOT** run HVAC system before allotting enough time for compounds to cure. Doing so could cause compound to be more prone to cracking.

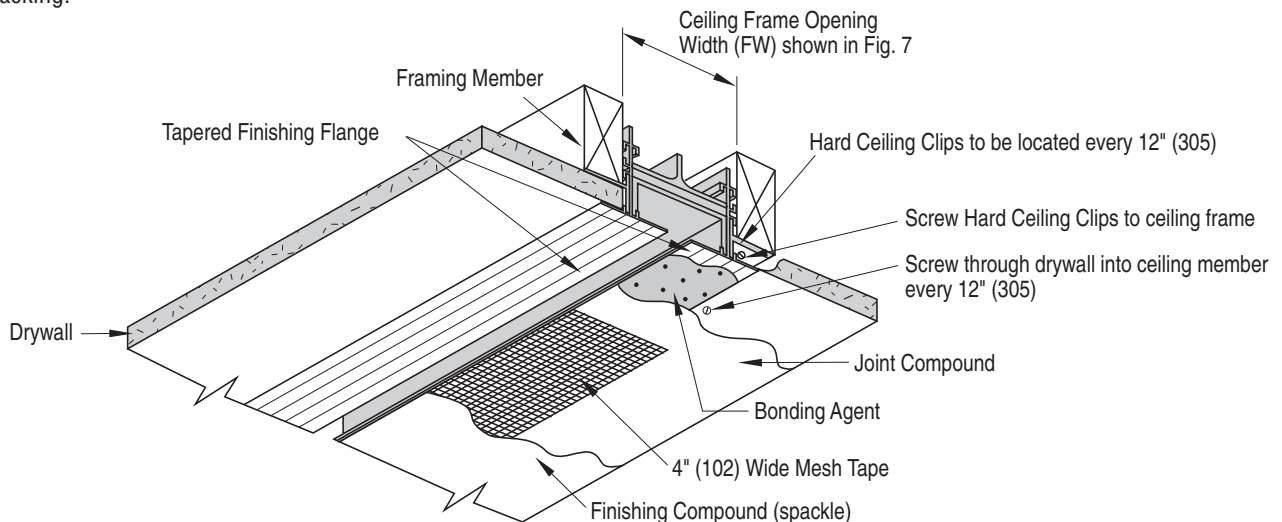

Figure 14. Summary of Frame/Border Style CC Installation.

## Installation Practices During Suspension Ceiling Construction

1. Install suspension ceiling T-Bar system prior to installing Flowline™ diffuser assuring proper dimensional layouts for simple diffuser installation.
2. If plenum is required and installation would be difficult after diffuser installation, hang plenum in approximate location using hanger wire on plenum seismic tabs. Otherwise, install plenum with hanger wire after step 6.
3. Diffusers (without concealed mounting brackets) are supplied with integral hanger brackets on 24" (610) centers. Attach hanger wire to secure to the building structure in accordance with local code requirements.
4. Lift each section into position individually and fasten to hanger wire to correct finishing height.  
(**Note:** If multiple sections are required, use alignment strips to join each section for a flush appearance.)
5. Attach ceiling grid sections to the diffuser using TC1 T-Bar Clip which can be field formed to proper angle.
6. Add end caps to diffuser if required.
7. Install plenums where required and secure to the building structure using plenum seismic tabs in accordance with local code requirements.
8. Attach ductwork to plenum inlet collar in accordance with recommended practices.
9. Connect all remaining T-Bar appropriately to diffuser and install acoustic ceiling tiles (trim to size as necessary).

### Typical Installation, Continuous Run Frame/Border Styles AA, GG and AG

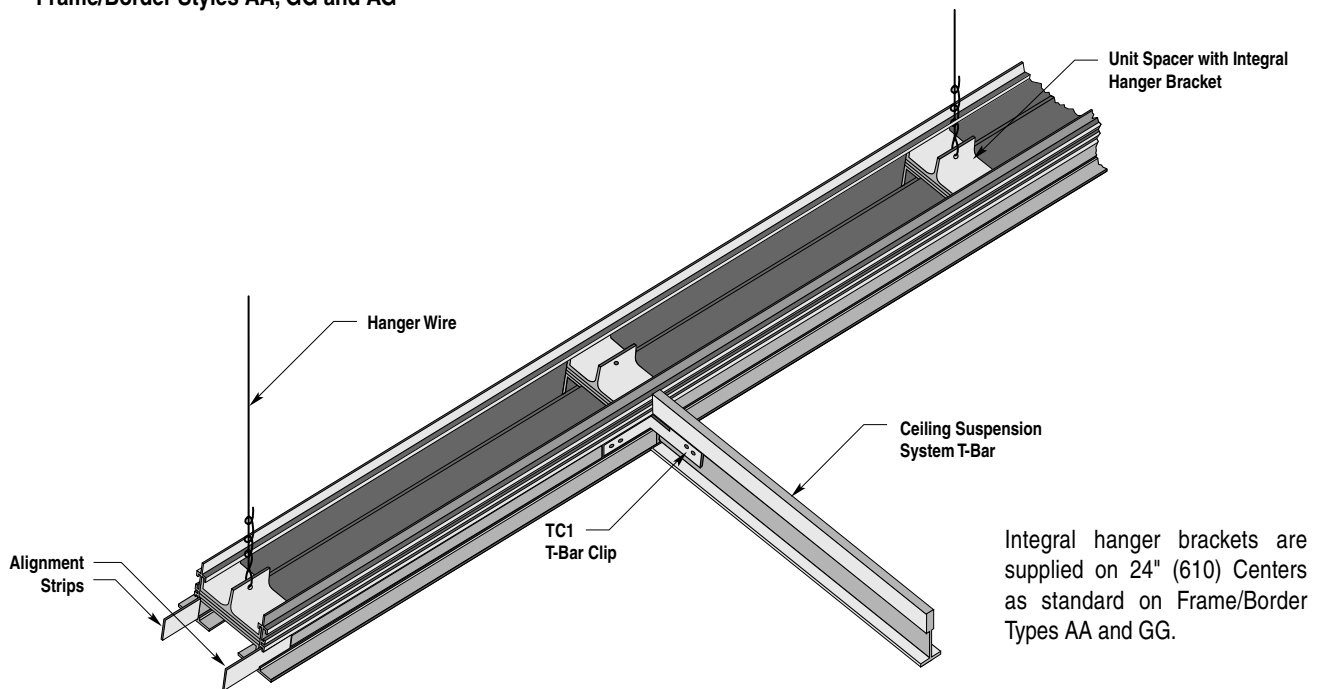
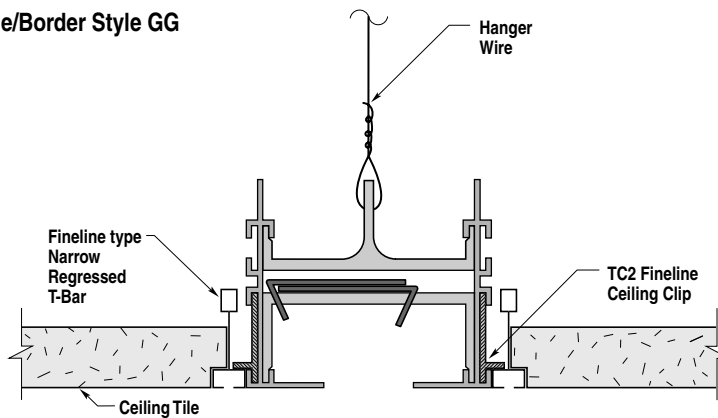

Figure 15. Typical suspension ceiling installation.

## Flangeless Frame/Border Style GG



USG 'Donn Fineline<sup>®</sup>', Chicago Metallic<sup>®</sup> 'Ultraline' and Armstrong Silhouette are three common examples of compatibility.

Figure 16. Example of Fineline suspension ceiling installation with type G frame.

## Installation Practices For FT Series Lay-in Diffusers (Modular Linear Diffuser/Plenum Assemblies)

1. Install suspension ceiling T-Bar system prior to installing Flowline™ diffuser assuring proper dimensional layouts for simple diffuser installation.
2. Diffusers are supplied with integral hanger brackets on 24" (610) centers.
3. Lift each modular diffuser/plenum assembly into position individually and rest on top of the T-Bar system.
4. Fasten hanger wire to correct finishing height on plenum seismic tabs and diffuser hanger brackets in accordance with local code requirements.
5. Attach ductwork to plenum inlet collar in accordance with recommended practices.
6. Install acoustic tiles (trim to size as necessary).

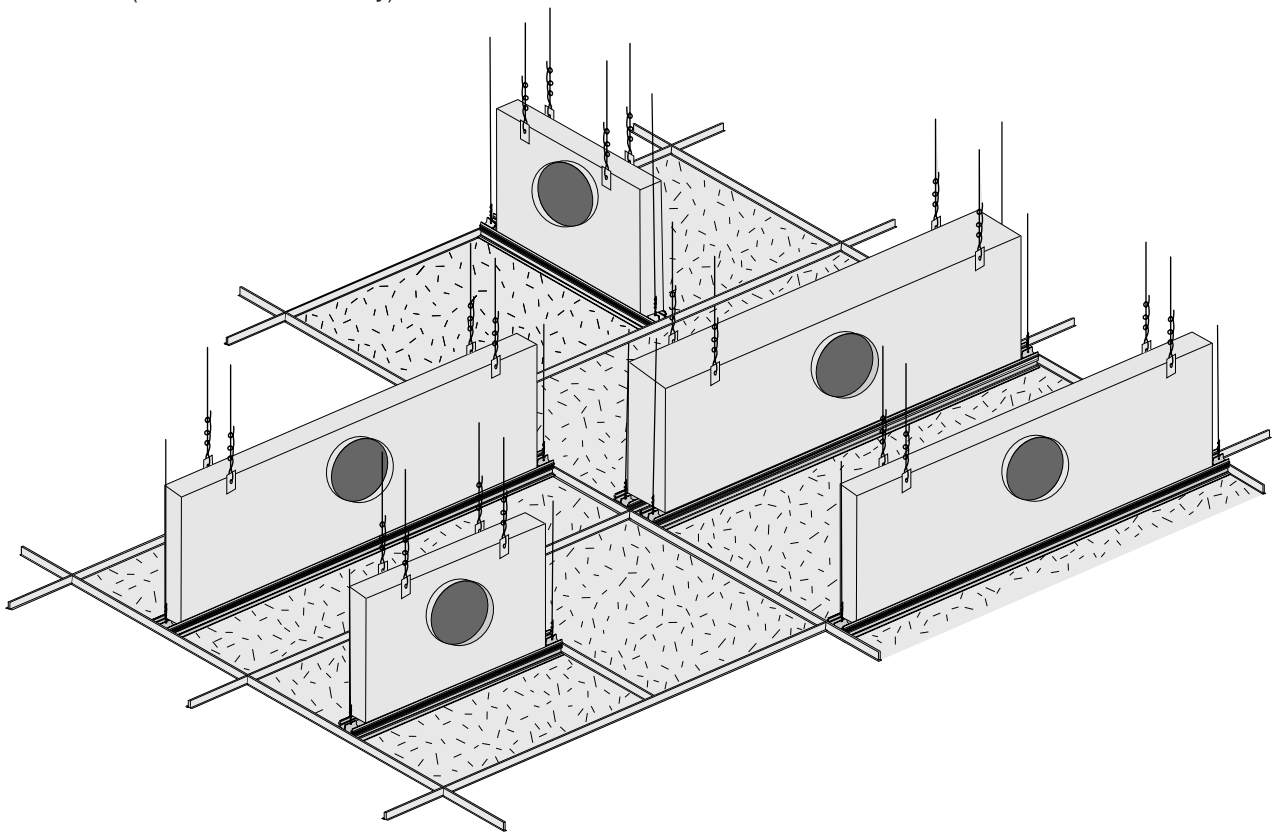

Figure 17. Typical lay-in diffuser configuration.

## Installation Practices For FM Series Modular Square Lay-in Ceiling Diffuser

1. Install suspension ceiling T-Bar system prior to installing Flowline™ diffuser assuring proper dimensional layouts for simple diffuser installation.
2. Unclip back pan from frame and pattern controller assembly.
3. Cut acoustic tile to size, see submittal, and insert into frame and pattern controller assembly.
4. Reattach back pan to frame, assuring that the clips are secure.
5. Where provided for seismic restraint, install WC1 hanger clips into the upper boss of the diffuser extrusion and move to each corner of unit. Diffuser extrusion may require field notching for insertion.
6. A. Suspended Ceilings: Standard units simply lay into the ceiling grid.  
B. Hard Ceilings: Mount the square modular diffuser into the ceiling in the same fashion as the exposed flange frame/border style AA during hard ceiling construction. HC1 or HC5 (optional) Hard Ceiling Clips are required.
7. Attach ductwork to plenum inlet collar in accordance with recommended practices.
8. Attach hanger wire to the hanger clips and secure to the building structure.

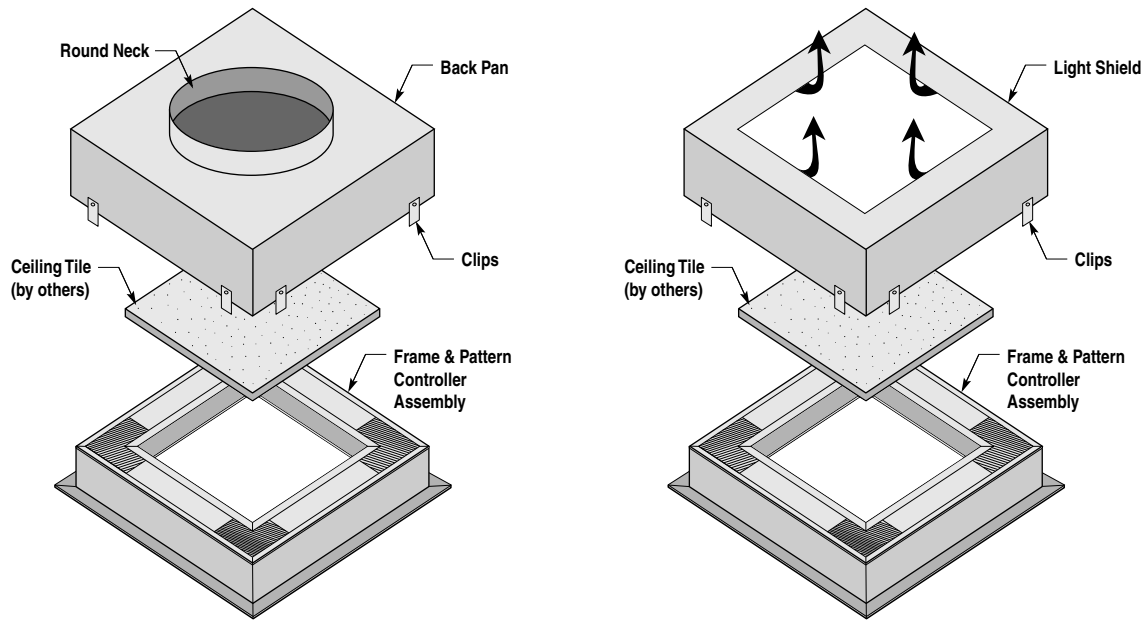

Figure 18. Typical square module diffuser assembly.

## Diffuser Field Cutting Procedure

### 1. Prepare Diffuser for Cutting

- A. Working from a table covered with indoor/outdoor carpet, measure the length of the diffuser to be cut and mark accordingly.
- B. Slide the top spacer sufficiently to allow for removal of the pattern controllers or completely remove top and bottom spacer as shown in Figure 19.
- C. Remove the pattern controllers as shown in Figure 20.
- D. Slide both top and bottom spacers back into the Flowline™ frame as shown in Figure 21, beyond the cut mark to clear the saw blade.

### 2. Cut Diffuser to Length

- A. Secure Flowline™ to table. Cut through both Flowline™ rails with the finished flanges facing up as shown in Figure 22.
- B. A 10" circular saw with fine tooth, high speed carbon steel cutting blade is recommended. Apply lubricant while cutting.
- C. Cut the pattern controllers by the same amount, so they will fit between the spacers.

### 3. Reassemble Diffuser

- A. Move both spacers to the end of Flowline™.
- B. Slide the top spacer sufficiently to allow for replacement of the pattern controllers.
- C. Reinstall the pattern controllers and slide the top spacer back over the pattern controllers.
- D. Lubricate the portion of the pattern controllers that fits between the top and the bottom spacer if necessary with WD-40 or other.
- E. All Flowline™ components may be reused after cutting, however, additional spacer kits are available.

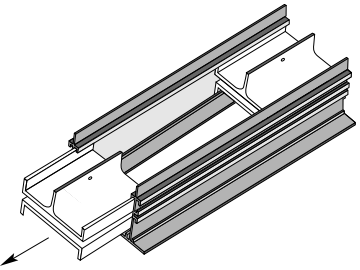

Figure 19. Diffuser Spacer Removal

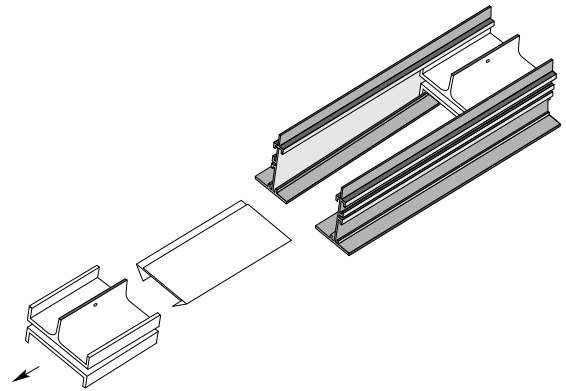

Figure 20. Removal of Pattern Controller

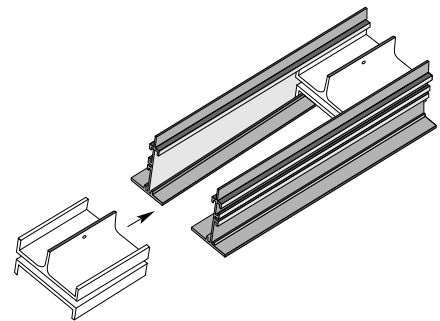

Figure 21. Replacement of Diffuser Spacer

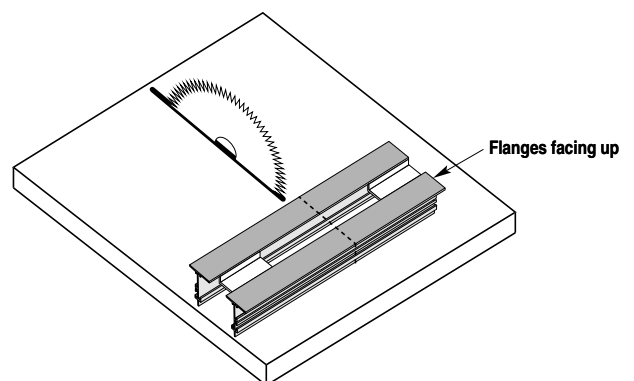

Figure 22. Field Cutting Diffuser

## Patten Controller Adjustable Instructions

### FLH Series Horizontal High Throw Pattern Controllers

Models: FLH10	1" (25) Slot	FLH25	2 1/2" (64) Slot
FLH15	1 1/2" (38) Slot	FLH30	3" (76) Slot
FLH20	2" (51) Slot		

The Flowline™ FLH Series continuous slot diffuser is designed primarily for ceiling applications. The adjustable pattern controllers, which are easily adjusted from the face, allow the discharge air to be directed to the left or right as well as downward. When positioned for horizontal discharge, a tight horizontal air pattern is produced that makes full use of the ceiling (coanda) effect, even at reduced air volumes. High induction characteristics maximize room air movement and mixing, making Flowline™ FLH Series eminently suitable for variable air volume systems.

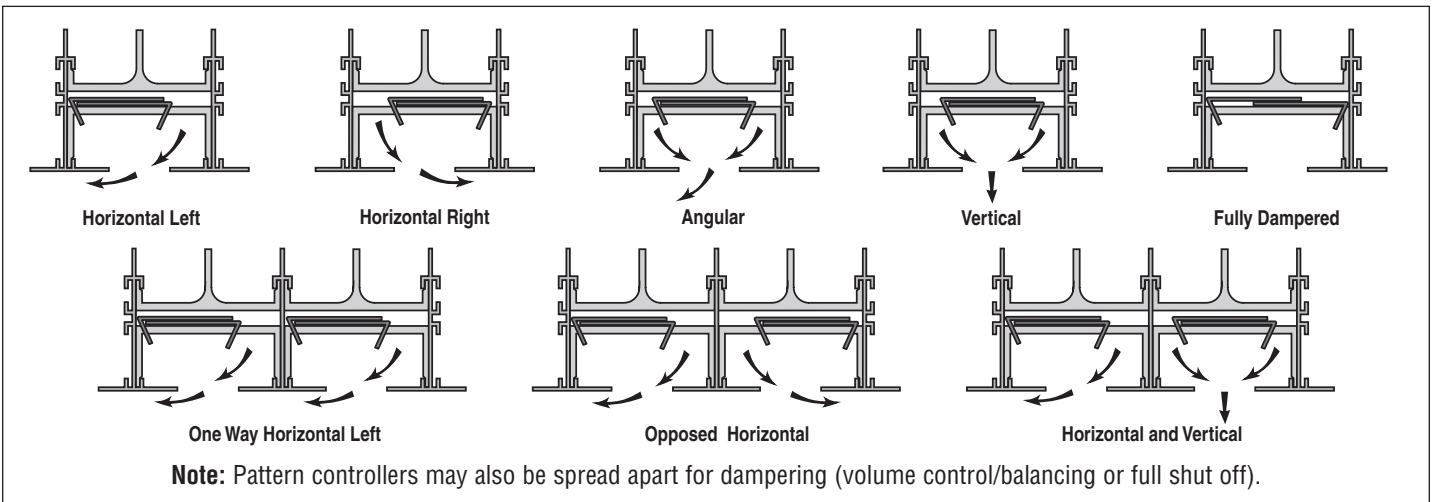

Figure 23. FLH Series Pattern Controller Adjustment.

### FLV Series Vertical Jet Throw Pattern Controllers

Models: FLV10	1" (25) Slot	FLV25	2 1/2" (64) Slot
FLV15	1 1/2" (38) Slot	FLV30	3" (76) Slot
FLV20	2" (51) Slot		

The Flowline™ FLV Series continuous slot diffuser is designed for both ceiling and high sidewall applications and provides total air pattern control flexibility. Similar in appearance to the FLH Series, the FLV Series features adjustable pattern controllers that direct the airstream perpendicular to the face, providing a strong vertical projection when installed in a ceiling and horizontally when installed in a sidewall application. The pattern controllers permit angular discharge, allowing the airstream to be directed left or right in a ceiling application and up or down in a sidewall application. The pattern controllers also provide a variable aperture capability to adjust performance to specific applications.

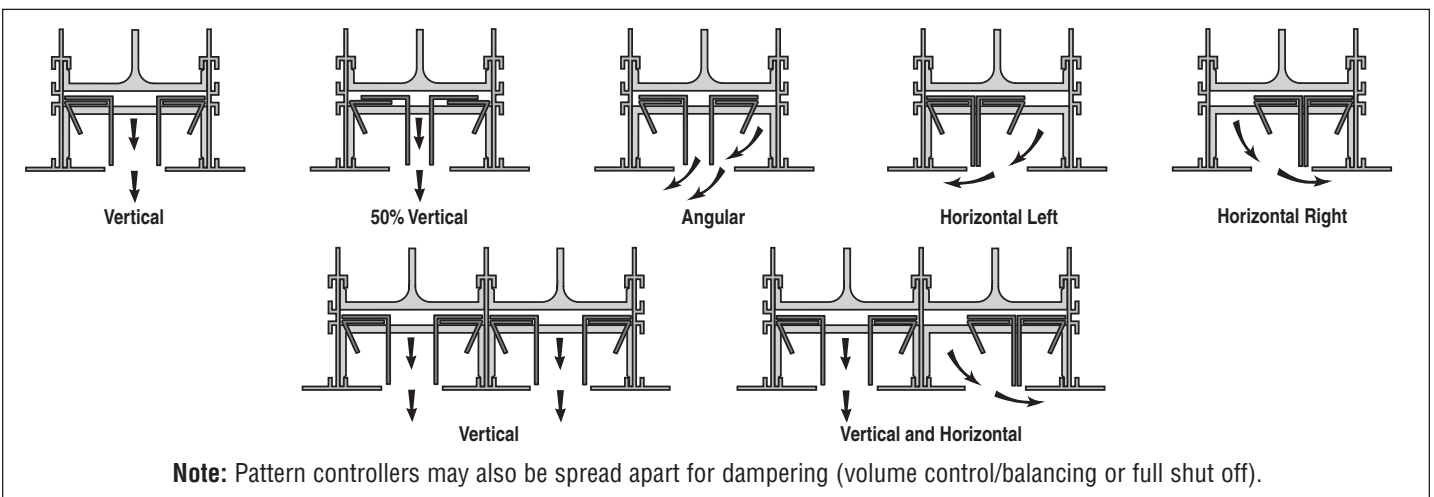
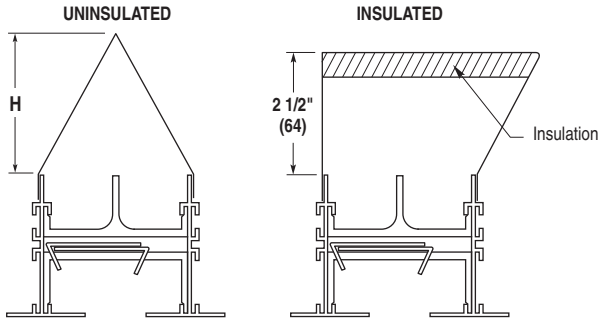

Figure 24. FLV Series Pattern Controller Adjustment.

## Accessories/Parts list

Note: For more detailed information, refer to Nailor website.

### Return Hood/Sight Shield



51% free area perforated corrosion resistant steel, painted flat black. Provided in 48" (1219) lengths. Field cut to length.

### Blank-Offs

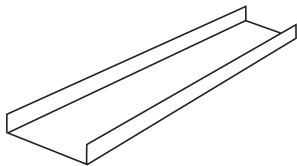

#### FLBO (10-30)

Corrosion resistant steel, painted flat black. Fits in neck of diffuser. Provided in 48" (1219) lengths. Field cut to length.

### Mounting Clips

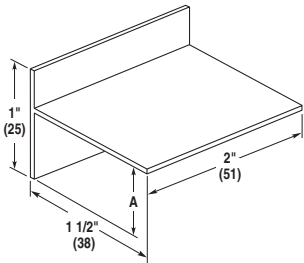

#### HC1, HC5

The HC1 and HC5 Hard Ceiling Clip can be used to mount the Flowline™ assembly with frame/border types **AA**, **CC** or **GG**, where 5/8" (16) or 1/2" (13) gypsum wallboard (drywall) is used.

	A Dim.
HC1	5/8" (16)
HC5	1/2" (13)

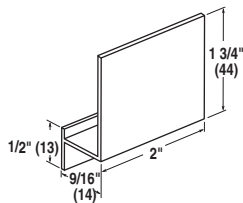

#### WC1

The WC1 Wall Clip is used to mount the Flowline™ assembly with frame/border type **AA** flush to a wall.

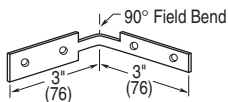

#### TC1

The TC1 T-Bar Clip is used to attach drop tees to the Flowline™ assembly.

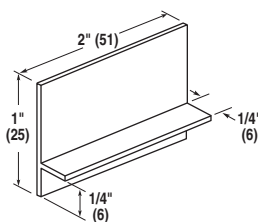

#### TC2

The TC2 Fineline T-Bar Clips are used to support and level the Flowline™ assembly in Bolt-Slot (Fineline type) suspension systems.

### Mounting Clips

#### HC2

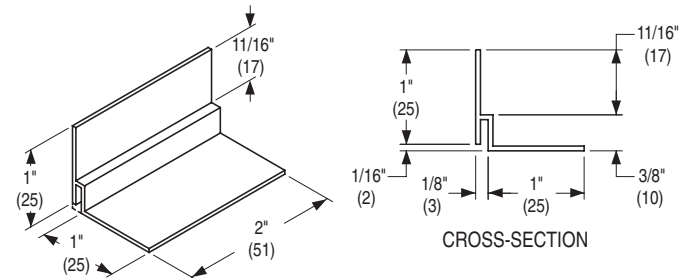

The HC2 Hard Ceiling Clip can be used to mount the Flowline™ assembly with frame/border type **G**, where standard 5/8" (16) gypsum wallboard (drywall) is installed below the frame face.

#### WC2

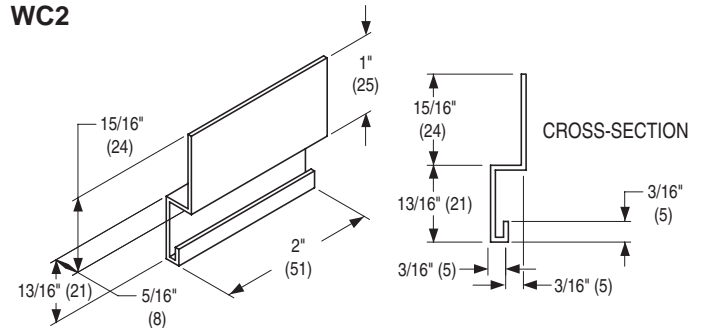

The WC2 Wall Clip can be used to mount the Flowline™ assembly with frame/border types **G** or **J**, flush to a wall.

#### HC3

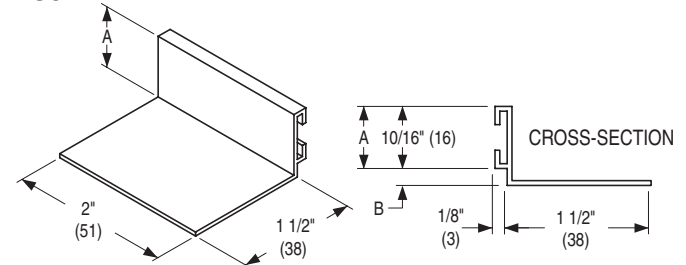

The HC3 Hard Ceiling Clip can be used to mount the Flowline™ assembly with frame/border type **K**, where standard 5/8" (16) gypsum wallboard (drywall) is used.

Flowline	Part No.	A Dim.	B Dim.
FLH10	HC3-10	13/16" (21)	3/16" (5)
FLH20	HC3-15	1 1/16" (27)	7/16" (11)
FLH30	HC3-20	1 5/16" (33)	11/16" (17)

---

**NOTE:**



**Houston, Texas**  
Tel: 281-590-1172  
Fax: 281-590-3086

**Las Vegas, Nevada**  
Tel: 702-648-5400  
Fax: 702-638-0400

**Toronto, Canada**  
Tel: 416-744-3300  
Fax: 416-744-3360

**Calgary, Canada**  
Tel: 403-279-8619  
Fax: 403-279-5035