



**ROUND COMBINATION FIRE/SMOKE DAMPER**  
 1 1/2 HR. LABEL • VERT. OR HORIZ.  
 FOR USE IN DYNAMIC OR STATIC SYSTEMS  
**MODEL: 1290FS**



**QUALIFICATIONS:**

- **UL 555 & CAN/ULC-S112 CLASSIFIED DYNAMIC FIRE DAMPER**  
1 1/2 hr. Label (File # R9492).
- **UL 555S CLASSIFIED SMOKE DAMPER** (File # R9492)  
Leakage Class I at 250°F or 350°F elevated temperature.
- **Meets NFPA 80, 90A, 92, 101 and 105 as well as IBC and NBC (Canada) Building Code requirements.**
- **City of New York. MEA # 366-03-M.**
- **California State Fire Marshal: Fire Damper Listing No. 3225-0935:0106.**
- **Maximum velocity: 4000 fpm @ 4" w.g. (20 m/s @ 1 kPa).**

Model 1290FS Damper is ideal for applications where building codes require both a fire damper for the protection of ductwork penetrations in walls or floors that have a fire resistance rating of up to 2 hours and also require a leakage rated damper for operational smoke control in static or dynamic smoke management systems.

The 1290FS Damper is an economical true round combination fire/smoke damper designed and qualified for round ductwork passing through metal or wood stud drywall partitions and masonry walls or floors. The 1290FS offers the lowest leakage class available and is qualified for installation with airflow in either direction.

**STANDARD CONSTRUCTION:**

- Frame:** 20 ga. (1.0) galvanized steel integral sleeve and retaining plates.
- Blades:** 2 x 20 ga. (1.0) galvanized steel laminated together.  
14 ga. (2.0) equivalent thickness.
- Linkage:** Jackshaft to blade.
- Bearings:** 1/2" (13) dia. self-lubricating oilite bronze.
- Axles:** 1/2" (13) dia. plated steel double bolted to blades.
- Jackshaft:** 1/2" (13) dia. cadmium plated steel.
- Blade Seal:** Silicone rubber. Peripheral gasket sandwiched between two piece blade.
- Heat Responsive Device (Controlled Closure):**  
ERL (Electric Resettable Link) is standard on dampers with electric actuators: 250°F (121°C) standard. 165°F (74°C), 212°F (100°C) and 350°F (177°C) available.  
PRL (Pneumatic Replaceable Link) is standard on dampers with pneumatic actuators: 212°F (100°C) standard. 165°F (74°C) and 280°F (138°C) available.

**Sizes (Duct Dia.):**

Minimum	Maximum
6" (152) dia.	24" (610) dia.

**Note:** Dampers available in 2" (51) increments.

**LEAKAGE CLASS / ELEVATED TEMPERATURE:**

- I @ 250°F (Standard)
- I @ 350°F

**DYNAMIC VELOCITY / PRESSURE RATING:**

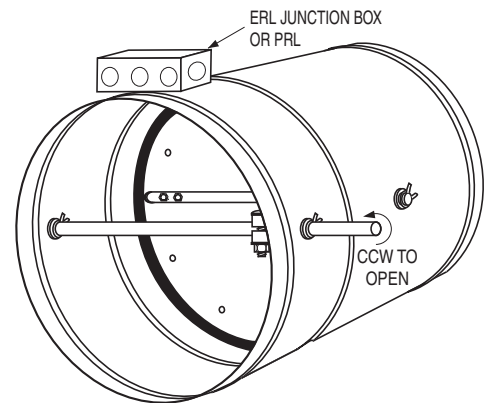
- 24 2000 fpm @ 4" w.g. (10 m/s @ 1 kPa) (Standard)
- 34 3000 fpm @ 4" w.g. (15 m/s @ 1 kPa)
- 44 4000 fpm @ 4" w.g. (20 m/s @ 1 kPa)

**ACTUATOR SELECTION:**

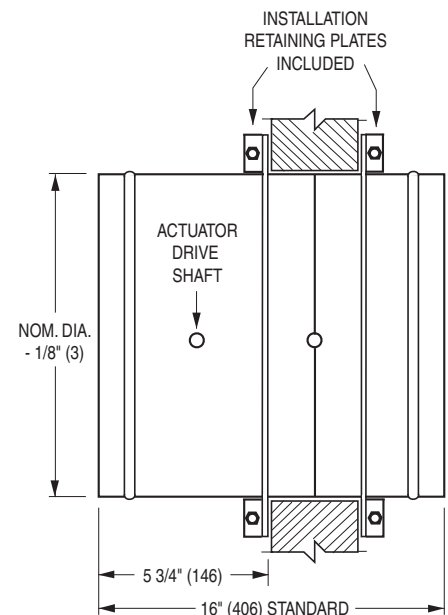
- Electric**    **Pneumatic** Specify model \_\_\_\_\_ .
- Actuators are mounted out of airstream only.

**ACTUATOR FAIL POSITION:**

Normally Closed. (Normally Open actuators are not available).



(Retaining Plates not shown)



Wall Thickness	Minimum Sleeve Length
4 to 8 (102 to 203)	16 (406)
10 to 12 (254 to 305)	20 (508)
14 to 16 (356 to 406)	24 (610)

**OPTIONS:**

- 304** 304 Stainless steel construction
- BS** Stainless steel bearings
- MLS-300** Position indicator switch pack
- MLS-400** Electric Fire Sensor (Re-openable control system). Includes dual heat sensors (165°F and 250°F or 350°F) and position indicator switch pack.

For installation instructions, see IOM-1290FSINST.  
 Dimensions are in inches (mm).

<b>SCHEDULE TYPE:</b>				
<b>PROJECT:</b>				
<b>ENGINEER:</b>	<b>DATE</b>	<b>B SERIES</b>	<b>SUPERSEDES</b>	<b>DRAWING NO.</b>
<b>CONTRACTOR:</b>	10 - 26 - 15	1200	4 - 28 - 14	1290FS-1



**STAINLESS STEEL ROUND COMBINATION  
FIRE/SMOKE DAMPER**  
1 1/2 HR. LABEL • VERT. OR HORIZ.  
FOR USE IN DYNAMIC OR STATIC SYSTEMS  
**MODEL: 1290FS-SS**



**QUALIFICATIONS:**

- **UL 555 & CAN/ULC-S112 CLASSIFIED DYNAMIC FIRE DAMPER** 1 1/2 hr. Label (File # R9492).
- **UL 555S CLASSIFIED SMOKE DAMPER** (File # R9492) Leakage Class I at 250°F or 350°F elevated temperature.
- **Meets NFPA 80, 90A, 92, 101 and 105 as well as IBC and NBC (Canada) Building Code requirements.**
- **City of New York. MEA # 366-03-M.**
- **California State Fire Marshal: Fire Damper Listing No. 3225-0935:0106.**
- **Maximum velocity: 2000 fpm @ 4" w.g. (10 m/s @ 1 kPa).**

Model 1290FS-SS damper is ideal for high humidity or mildly corrosive applications where building codes require both a fire damper for the protection of ductwork penetrations in walls or floors that have a fire resistance rating of up to 2 hours and also require a leakage rated damper for operational smoke control in static or dynamic smoke management systems.

The 1290FS-SS damper is a true round combination fire/smoke damper designed and qualified for round ductwork passing through metal or wood stud drywall partitions and masonry walls or floors. The 1290FS-SS offers the lowest leakage class available and is qualified for installation with airflow in either direction. Available in either Type 304 or 316 stainless steel.

**STANDARD CONSTRUCTION:**

- Frame:** 20 ga. (1.0) stainless steel integral sleeve and retaining plates.
- Blades:** 2 x 20 ga. (1.0) stainless steel laminated together. 14 ga. (2.0) equivalent thickness.
- Linkage:** Stainless steel; Jackshaft to blade.
- Bearings:** 1/2" (13) dia. stainless steel.
- Axles:** 1/2" (13) dia. stainless steel double bolted to blades.
- Jackshaft:** 1/2" (13) dia. stainless steel.
- Blade Seal:** Silicone rubber. Peripheral gasket sandwiched between two piece blade.

**Heat Responsive Device (Controlled Closure):**

ERL (Electric Resettable Link) is standard on dampers with electric actuators: 250°F (121°C) standard. 165°F (74°C), 212°F (100°C) and 350°F (177°C) available. PRL (Pneumatic Replaceable Link) is standard on dampers with pneumatic actuators: 212°F (100°C) standard. 165°F (74°C) and 280°F (138°C) available.

**Sizes (Duct Dia.):**

Minimum	Maximum
6" (152) dia.	24" (610) dia.

**Note:** Dampers available in 2" (51) increments.

**CONSTRUCTION TYPE:**

- 304** Type 304 Stainless Steel construction (Standard)
- 316** Type 316 Stainless Steel construction (Optional)

**LEAKAGE CLASS / ELEVATED TEMPERATURE:**

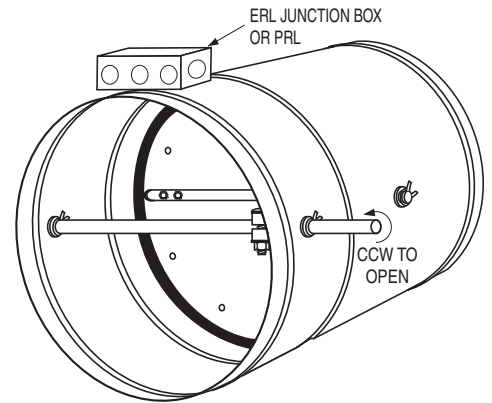
- 250°F** (Standard)
- 350°F** (Optional)

**DYNAMIC VELOCITY / PRESSURE RATING:**

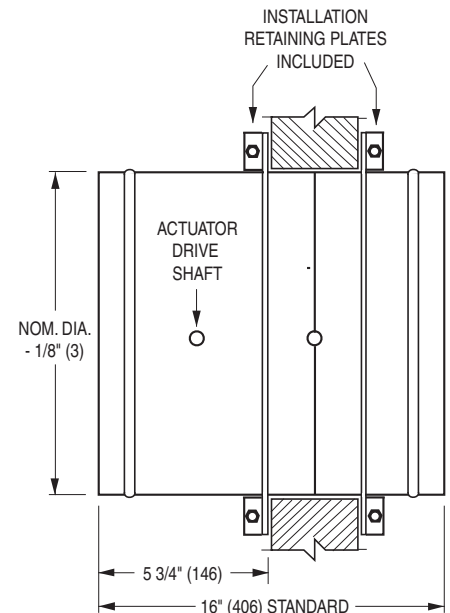
24 2000 fpm @ 4" w.g. (10 m/s @ 1 kPa) (Standard)

**ACTUATOR SELECTION:**

- Electric**    **Pneumatic** Specify model \_\_\_\_\_ .
- Actuators are mounted out of airstream only.



(Retaining Plates not shown)



Wall Thickness	Minimum Sleeve Length
4 to 8 (102 to 203)	16 (406)
10 to 12 (254 to 305)	20 (508)
14 to 16 (356 to 406)	24 (610)

**ACTUATOR FAIL POSITION:**

Normally Closed. (Normally Open actuators are not available).

**OPTIONS:**

- MLS-300** Position indicator switch pack
- MLS-400** Electric Fire Sensor (Re-openable control system). Includes dual heat sensors (165°F and 250°F or 350°F) and position indicator switch pack.

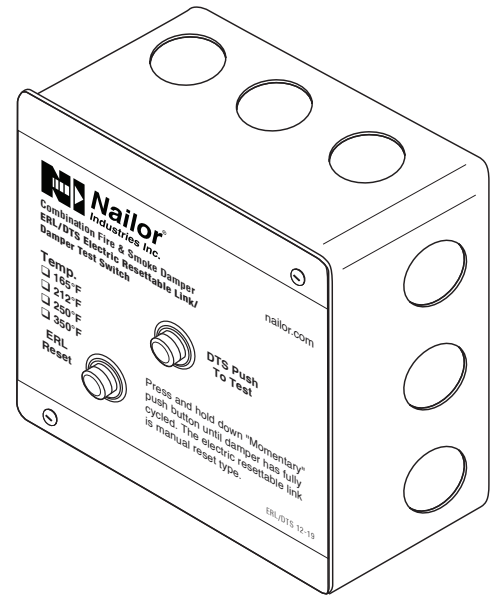
For installation instructions, see IOM-1290FSINST. Dimensions are in inches (mm).

<b>SCHEDULE TYPE:</b>	<b>DATE</b>	<b>B SERIES</b>	<b>SUPERSEDES</b>	<b>DRAWING NO.</b>
<b>PROJECT:</b>	4 - 28 - 14	1200	8 - 16 - 12	1290FS-SS-1
<b>ENGINEER:</b>				
<b>CONTRACTOR:</b>				

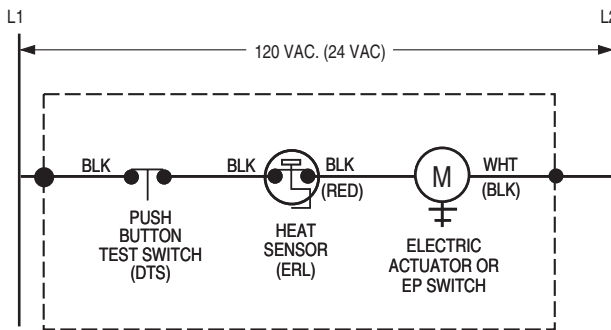
The DTS (Damper Test Switch) is an optional "momentary" push button test switch available on all Nailor smoke and combination fire/smoke dampers. The DTS provides the ability to "cycle test" the damper by pushing and holding down the button until the damper has cycled and closure has been visually verified, either by inspecting the damper through the access door or by confirmation at a remote control panel when equipped with the optional MLS-300 position indicator.

The DTS is mounted right on the damper and enables a single maintenance person to test and cycle the damper, eliminating the need for help from another person in the control room.

When a combination fire/smoke damper is ordered, the DTS is combined with the ERL (Electric Resettable Link), in a common enclosure.



## WIRING DIAGRAMS:



MOUNTED ON DAMPER (FACTORY WIRING TERMINATES AT SPLICE POINTS INDICATED INSIDE 4" x 4" ELECTRICAL BOX)

Figure 1. DTS/ERL Damper Test Switch with Electric Resettable Link

### Belimo Actuator Aux. Switch Wiring Connections

Model Series	Open (OP)	Closed (CL)
FSTF	Orange / Gray	Violet / Red
FSLF / FSAFA	Gray / Gray	Violet / Violet
FSNF / FSAFB	White S4 / S6	White S1 / S2

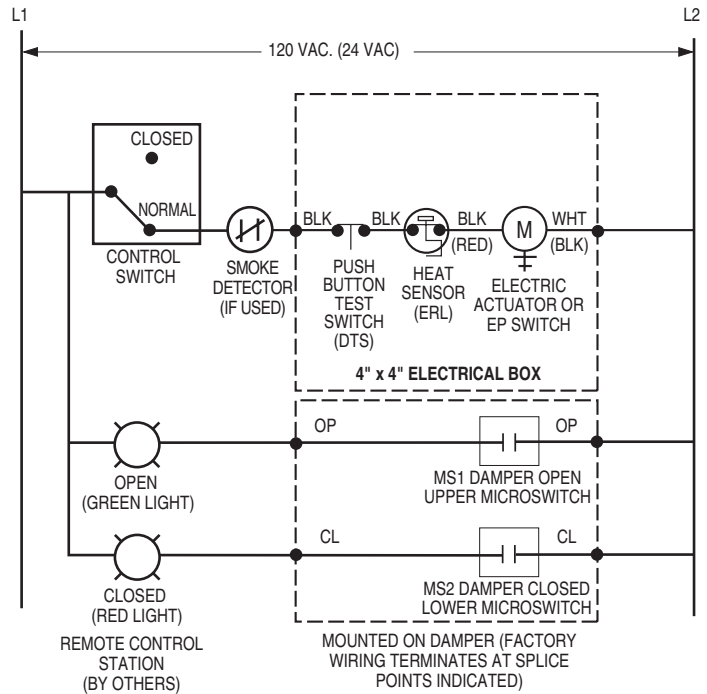


Figure 2. DTS/ERL with MLS-300 Belimo (actuator aux. switches) Position Indicator Package

SCHEDULE TYPE

PROJECT

ENGINEER

CONTRACTOR

DATE

9 - 3 - 20

B SERIES

FD-ACC

SUPERSEDES

3 - 29 - 18

DRAWING NO.

DTS

## WIRING DIAGRAMS:

### Honeywell Actuator Aux. Switch Wiring Connections

Model Series	Open (OP)	Closed (CL)
MSXX04	Yellow / Yellow	Blue / Blue
MSXX20	Yellow / Yellow	Blue / Blue

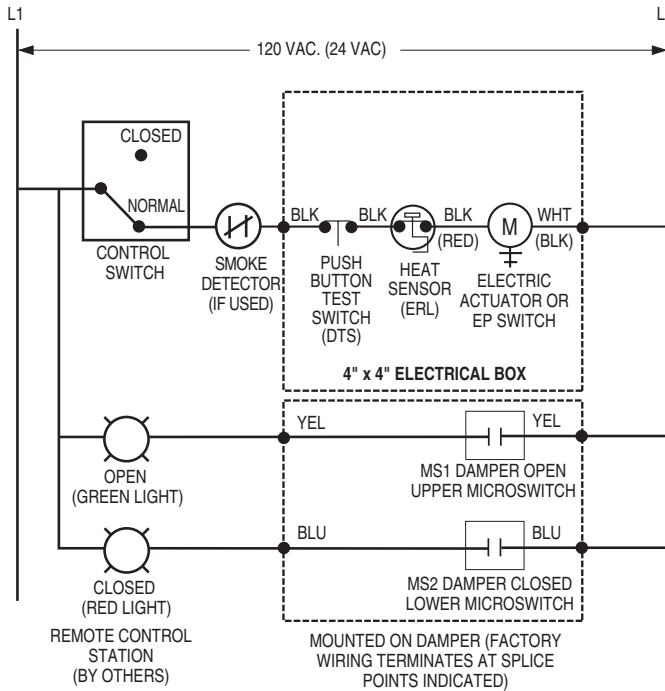


Figure 3. DTS/ERL with MLS-300 Nailor or Honeywell (actuator aux. switches) Position Indicator Package

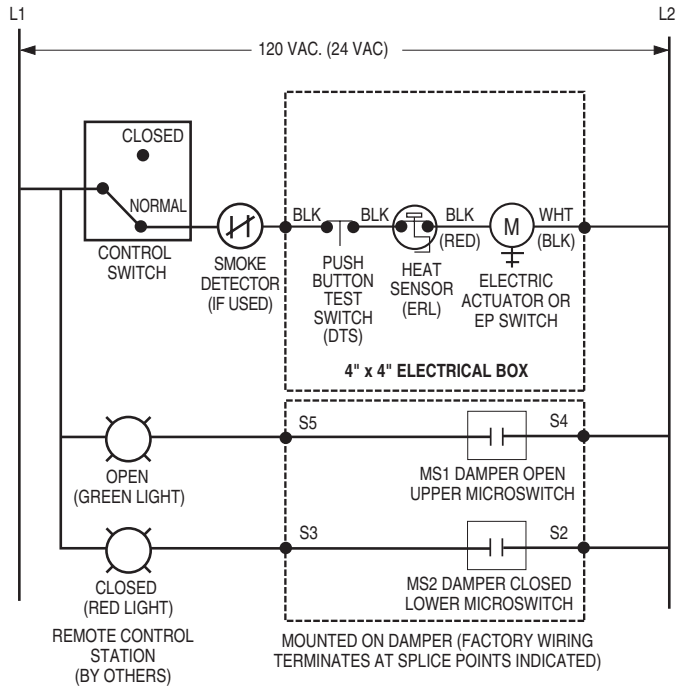
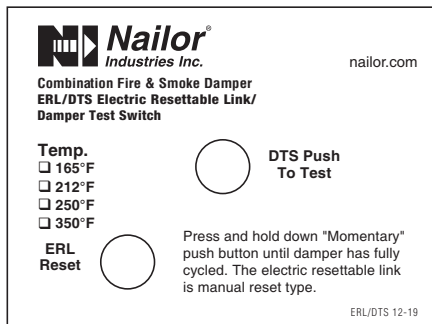
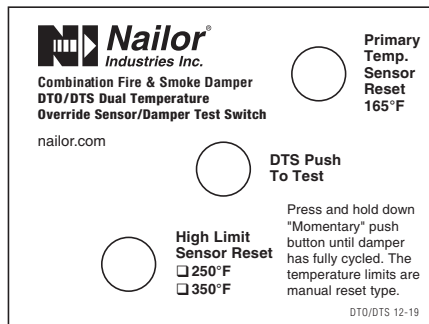


Figure 4. DTS/ERL with MLS-300 Siemens GJD Series (actuator auxiliary switches) Position Indicator Package

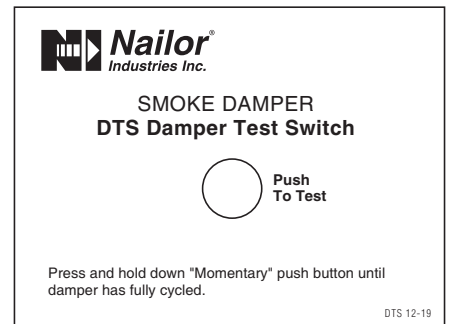
## DTS LABEL VARIATIONS:



ERL/DTS Combination Fire/Smoke Damper



DTO/DTS Combination Fire/Smoke Damper



DTS Smoke Damper

SCHEDULE TYPE

PROJECT

ENGINEER

CONTRACTOR

Page 2 of 2

DATE

B SERIES

SUPERSEDES

DRAWING NO.

9 - 3 - 20

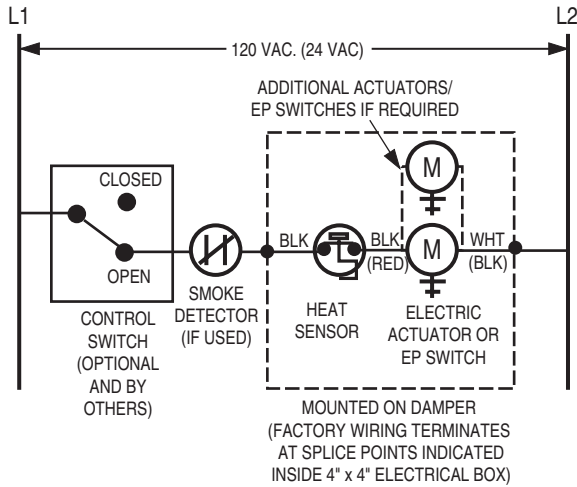
FD-ACC

3 - 29 - 18

DTS



# ELECTRIC RESETTABLE LINK FOR COMBINATION FIRE / SMOKE DAMPERS MODEL: ERL



## APPLICATION AND OPERATION:

The ERL Electric Resettable Link (heat sensor) is standard on all Nailor combination fire/smoke dampers with an electric actuator. The ERL is a thermally responsive bimetal disc/thermostat that opens and closes electrical contacts at a specific calibrated temperature. The ERL is a UL Classified Heat Responsive Device. The standard ERL has a fixed temperature setting of 250°F (121°C) which is the UL listed elevated/degradation temperature of the damper/actuator assembly. A 350°F (177°C) elevated temperature classification and ERL is available as an option.

[A 165°F and 212°F (74°C and 100°C) ERL are also available. Local codes have specified 165°F (74°C) widely in the past.]

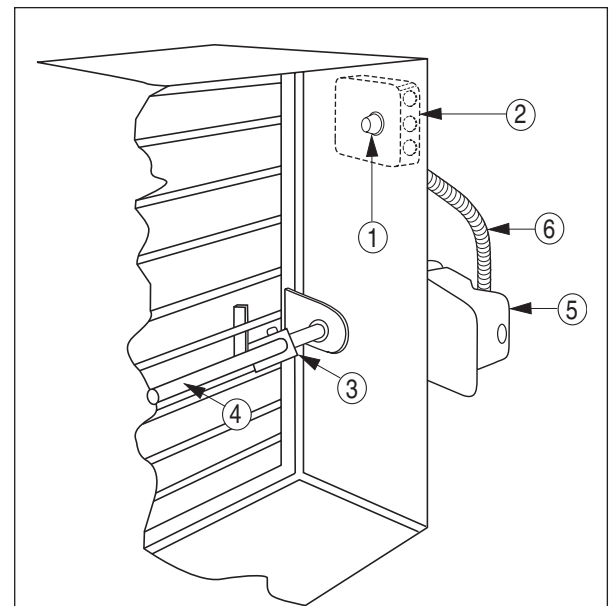
The ERL's function is to sense an abnormally high temperature, as caused by a fire and allow the damper to close in order to prevent the spread of fire and smoke. The sensor interrupts power to the actuator and the actuator's spring return mechanism causes the damper to close and lock.

In smoke control mode, when a signal is detected via a normally closed smoke detector connection, the damper will close and remain closed until the smoke signal ceases. The system will then reset when power is re-applied and the damper will open. The damper may be closed at anytime by placing a control switch (optional and by others) in the closed position.

The ERL in combination with all Nailor qualified electric or pneumatic actuators provides controlled closure and eliminates the instantaneous damper closure associated with traditional fusible links that can cause damage to the ductwork.

The ERL sensor is of the manual reset type and can be reset after the temperature has cooled down below the sensor set point. Exposure to actual fire conditions may render these devices unusable. In this case, it is recommended that a careful inspection of the damper, actuator and ERL be performed.

The ERL requires factory installation and wiring together with the associated actuator to meet UL requirements. If the damper is provided with a pneumatic actuator, an EP switch is required.



## DESCRIPTION:

1. ERL 165, 212, 250, 350 Electric Resettable Link (heat sensor)
2. Electrical Junction Box (and EP Switch with Pneumatic Actuator)
3. Over-Center Knee Lock
4. Jackshaft
5. Actuator
6. Flexible Conduit

**SCHEDULE TYPE**

**PROJECT**

**ENGINEER**

**CONTRACTOR**

Dimensions are in inches (mm).

**DATE**

**B SERIES**

**SUPERSEDES**

**DRAWING NO.**

9 - 9 - 20

FD-ACC

9 - 23 - 02

ERL

## Powers™ Controls No. 4 Pneumatic Damper Actuator

### Product Description

The No. 4 Pneumatic Damper Actuator is a totally enclosed pneumatic piston type actuator designed to actuate dampers for ventilating systems, mixing box control, and other applications requiring a large, effective diaphragm area and long stroke. The No. 4 Hesitation Actuator is frequently used to operate the outdoor air damper on unit ventilators.

### Product Numbers

See Table 1.

### Prerequisites

- Ensure all kits are ordered and available for installation. Kits are listed with each mounting application.
- Have the damper manufacturer drill the mounting holes.
- Have the damper manufacturer weld the mounting lug to the damper frame in frame mounting installations.



#### WARNING:

Do not remove the jam nut (Figure 1). Spring is under heavy load. Repair by trained personnel only.

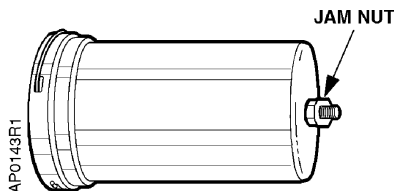


Figure 1. Actuator Jam Nut Location.

### Required Tools

- Flat-blade screwdriver
- Adjustable crescent wrench
- Pliers

### Warning/Caution Notations

<b>WARNING</b>		Personal injury/loss of life may occur if the user does not follow a procedure as specified.
<b>CAUTION</b>		Equipment damage, or loss of data may occur if the user does not follow a procedure as specified.

### Installation

#### Extended Shaft Mounting-Pivot Actuator

**Expected Installation Time:** 28 minutes

Actuators: 331-3000, 331-3001, 331-3002, 331-2973, or 331-3004.

These assemblies are designed for 90° damper rotation.

**NOTE:** Clevis mounts in Crank Radius Hole No. 1 for 90° damper rotation.

1. Slip 3/4-inch (19 mm) diameter hole in the mounting plate over the damper shaft (Figure 2).

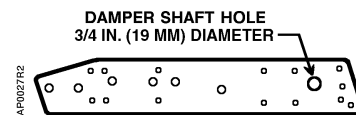


Figure 2. Actuator Mounting Plate.

2. Slip the crank over the 3/8 through 1/2-inch (10 through 13-mm) diameter damper shaft (Figure 3).

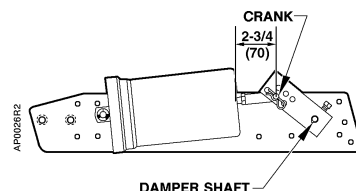


Figure 3. Extended Shaft Mounting.

3. Position the mounting plate and attach it to the duct with four screws.

**Table 1. No. 4 Damper Actuator Product Numbers.**

Description	Mounting Style	Product Numbers				
		Nominal Spring Range				
		3-7 psi (21-48 kPa)	3-13 psi (21-90 kPa)	5-10 psi (35-69 kPa)	8-13 psi (55-90 kPa)	2-3, 8-13 psi (14-21, 55-90 kPa) Hesitation Model
Actuator, mounting screws (non-pivot)	Front	331-2910	—	331-2917	331-2963	—
Actuator, bracket (non-pivot) 3-inch stroke for unit ventilator	Fixed	331-2911	—	331-2934	331-2966	331-2927
Actuator, bracket (non-pivot) 2-3/8 inch stroke for unit ventilator	Fixed	—	—	—	—	331-2974
Actuator, mounting plate, ball joint connector	Fixed	331-3015	331-3018	331-3016	331-3017	331-3019
Actuator, mounting plate, ball joint connector with positioning relay	Fixed	—	—	—	332-3017	—
Actuator, integral pivot	Pivot	331-2904 <sup>1</sup>	331-2905 <sup>1</sup>	331-2906 <sup>1</sup>	331-2961 <sup>1</sup>	331-2909 <sup>1</sup>
Actuator, integral pivot, clevis and clevis pin for use with frame mounting accessory	Pivot	331-2929	331-2930	331-2931	331-2968	—
Actuator, integral pivot with pivot post <sup>2</sup>	Universal kit	331-3000	331-3001	331-3002	331-2973 <sup>1</sup>	331-3004
Actuator, integral pivot with pivot post, and positioning relay <sup>2</sup>	Universal kit with positioning relay	—	—	—	332-2973	—

<sup>1</sup> UL Recognized Components for Fire/Smoke Applications.

<sup>2</sup> Mounted on plate for extended shaft with clevis and crank for 3/8-inch (10-mm), 7/16-inch (11-mm), or 1/2-inch (13-mm) diameter shaft. Parts for frame mounting (blade drive) are included with kit.

**NOTE:** When the actuator is ordered with universal mounting, the mounting plate, pivot post and hardware, clevis, damper crank, rocker arm, and all screws/nuts are included. Order other frame mounting accessories as required if not supplied by damper manufacturer.



## Installation, Continued

### Extended Shaft Mounting-Fixed Actuator

**Expected Installation Time:** 28 minutes

Actuator with mounting bracket: 331-2911,  
 331-2966, 331-2934, 331-2927, or 331-2974

Clevis: 331-801

Linkage Kit: 331-958

1. Determine the application from Table 2 and then select appropriate "X" and "Y" dimensions. Select a rigid section of the duct, if possible, and draw these lines on the duct.



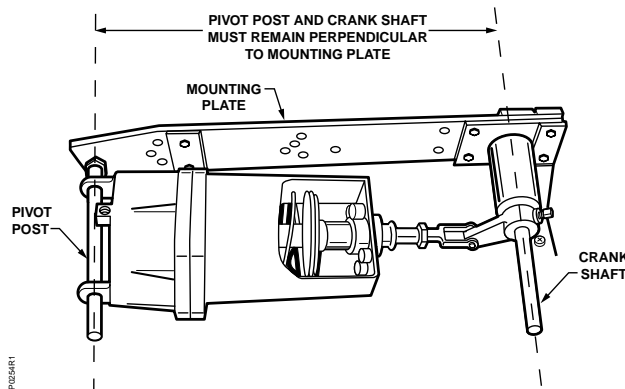
**CAUTION:**

It is important to use the "X" and "Y" dimensions from Table 2 to position the actuator to ensure that the crank is approximately perpendicular to the actuator shaft at half its stroke (see Figure 4). This will prevent the linkage from scissoring or locking up.

**Table 2. Fixed Mounted Assembly Dimensions.**

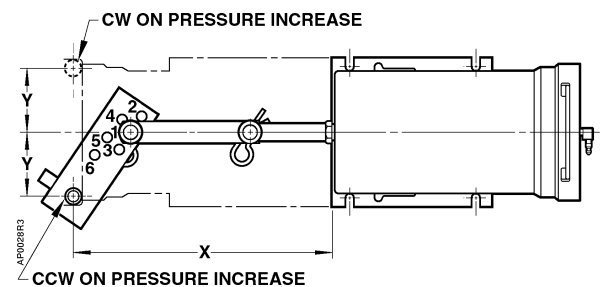
Application	Dimensions in Inches (mm)		Crank Radius Hole
	X	Y	
4-inch (102 mm) Stroke – 90° Rotation	8-1/2 (216)	2 (51)	1
4-inch (102 mm) Stroke – 70° Rotation	8-1/2 (216)	3 (76)	2
3-inch (76 mm) Stroke – 90° Rotation	8 (203)	1-1/2 (38)	3
3-inch (76 mm) Stroke – 60° Rotation	8 (203)	2-1/2 (64)	4

**NOTE:** Crank Radius Holes No. 5 and 6 are used for No. 3 Pneumatic Damper Actuators only.



**Figure 4. Perpendicular Mounting.**

2. Place front of actuator on "X" dimension line so that the actuator shaft faces damper shaft. Place center line of actuator over "Y" dimension line (see Figure 5).
3. Thread Clevis 331-801 on to actuator shaft and tighten against locknut. Assemble Linkage Kit 331-958 to actuator assembly (see Figure 4). The linkage is assembled so that the damper shaft will rotate counterclockwise as actuator pressure increases. This is a typical normally closed damper installation.



**Figure 5. Fixed Mounted Actuator Assembly.**

### Frame Mounting

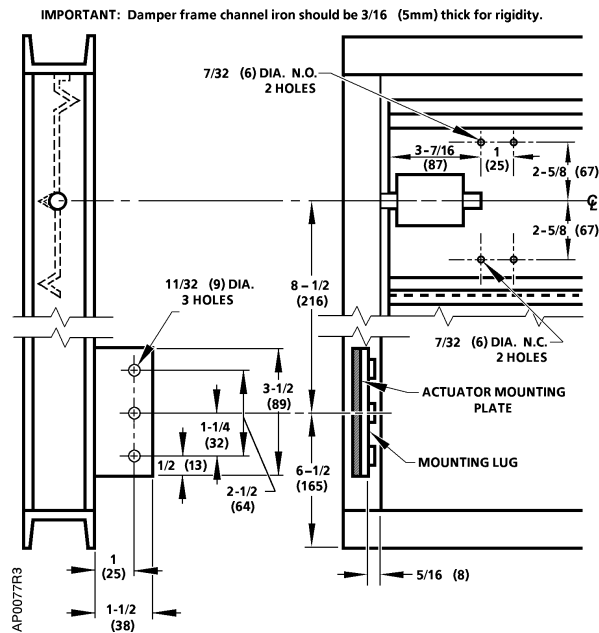
**Expected Installation Time:** 3 hours

Actuator: 331-3000, 331-3001, 331-3002, 331-2973,  
 or 331-3004.

Mounting lug: 331-569

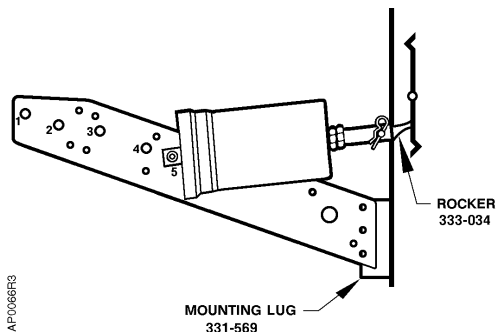
1. If the damper frame is aluminum, light gauge sheet metal, or an unusual shape, bolt a 3/16-inch (5 mm) thick, flat piece of steel to the frame where the mounting lug is to attach. The mounting lug can then be welded to it.
2. Weld the mounting lug parallel and 5/16-inch (8 mm) from the inside edge of the damper frame and perpendicular to it (Figure 6). Weld the lug along both sides. The lug should be as close as possible to the corner of the damper frame to minimize deflection. The damper manufacturer should weld the lug.
3. If the damper frame is aluminum, light gauge sheet metal, or an unusual shape, bolt a 3/16-inch (5-mm) thick, flat piece of steel to the frame. Then, weld the mounting lug to the piece of steel.





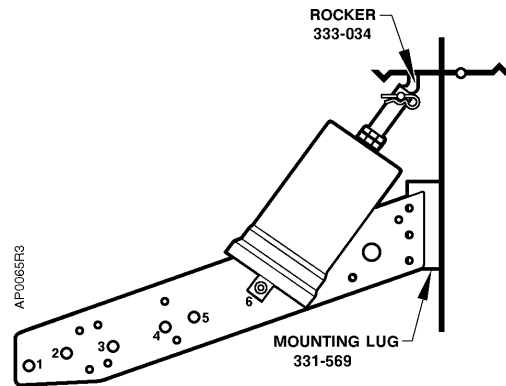
**Figure 6. Frame Mounting Dimensions.  
 Dimensions in Inches (Millimeters).**

4. Attach rocker to blade in proper position for normally open or normally closed damper (Figure 6).
5. Attach mounting plate to mounting lug.
  - a. Normally closed damper: attach plate to lug (Figure 7). Place pivot post in Hole 3.



**Figure 7. No. 4 Actuator Frame Mounting,  
 Normally Closed Damper.**

- b. Normally open damper: attach plate to lug (Figure 8). Place pivot post in Hole 6.



**Figure 8. No. 4 Actuator Frame Mounting,  
 Normally Open Damper.**

6. Fasten clevis to rocker. Discard crank and other parts not used.
7. The actuator mounting plate has a tendency to pivot at the point where the lug is welded to the damper frame when the actuator strokes. It is recommended that some means be devised in the field to prevent this from happening. A threaded rod attached to the mounting plate and duct wall will normally work.

## Hesitation Actuator Adjustment

**Expected Installation Time:** 15 minutes

1. To obtain an initial hesitation point, add air pressure to actuator until shaft travels the desired distance.
2. Turn locknuts on cycle adjustment rods until they contact lower housing and then lock together. Tighten cycle adjustment nuts evenly to ensure smooth operation.

The installation is now complete.

## References

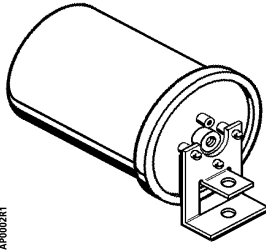
AP 331-2 Powers™ Controls No. 4 Pneumatic Damper Actuator Technical Instructions, (155-032P25)

TB 181, Maximum Thrust Ratings of Pneumatic Damper Actuators Technical Bulletin, (155-219P25)

Information in this publication is based on current specifications. The company reserves the right to make changes in specifications and models as design improvements are introduced. Other product or company names mentioned herein may be the trademarks of their respective owners. © 2002 Siemens Building Technologies, Inc.

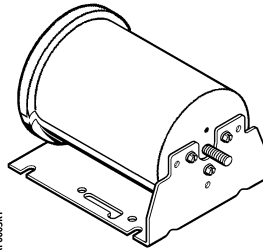
## POWERS™ Controls

### No. 3 Pneumatic Damper Actuator



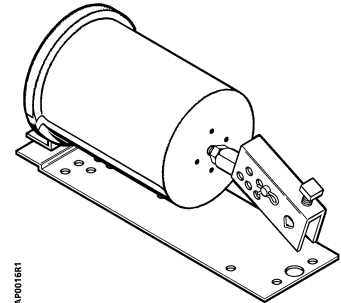
AP00021

331-4312 Pivot Mounting



AP00021

331-4313 Fixed Mounting



AP00021

331-4311 Extended Shaft Mounting

#### Description

The POWERS Controls No. 3 Pneumatic Damper Actuator is a compact, totally enclosed, rolling diaphragm-type actuator designed for modulating or two-position actuation of dampers or air valves.

#### Features

- All metal body construction
- Totally enclosed to protect internal parts
- Variety of spring ranges for sequencing
- Fixed or pivot mounting models
- Pivot mounting for extended shaft
- Positioning relay (optional)
- Variety of mounting/linkage kits for special applications
- Threaded shaft for easy mounting to accessory thread

#### Product Numbers

See Table 1.

#### Application

Typical applications are for control of mixing box dampers or air valves, and damper control for unit ventilators, unit conditioners and other HVAC applications.

These compact, totally enclosed actuators are easily installed either directly within the mixing box or unit enclosure, or externally, as required for each application.

**Table 1. Product Numbers for No. 3 Pneumatic Damper Actuators.**

Description	Mounting Style	Part No.		
		Nominal Spring Range		
		3-7 psi (21-48 kPa)	5-10 psi (35-69 kPa)	8-13 psi (55-90 kPa)
Actuator	Front	331-4310	331-4510	331-4810
Actuator, bracket	Fixed	331-4313	331-4513	331-4813
Actuator, bracket, clevis	Fixed	331-4314	331-4514	331-4814
Actuator, integral pivot	Pivot	331-4312	331-4512	331-4812
Actuator, integral pivot with pivot post *	Extended shaft	331-4311	331-4511	331-4811
Actuator, integral pivot with pivot post *	Extended shaft kit with positioning relay	—	—	332-4811
Actuator, bracket, ball joint connector	Fixed	331-4331	331-4531	331-4831
Actuator, bracket, ball joint connector and positioning relay	Fixed	—	—	332-4831
Extended shaft with 90° barb fitting (for fume hood controller applications)	Extended shaft	—	—	546-00020

\* Mounted on plate for extended shaft with clevis and crank for 3/8-inch (10-mm), 7/16-inch (11-mm), or 1/2-inch (13-mm) diameter shaft.

**NOTE:** When the actuator is ordered with extended shaft mounting, the mounting plate, pivot post and hardware, clevis, damper crank, rocker arm, and all screws/nuts are included. Order other frame mounting accessories as required if not supplied by damper manufacturer.

Specifications		
Effective diaphragm area		8 inches <sup>2</sup> (51.6 cm <sup>2</sup> )
Stroke		2-3/8 inches (6 mm) *
Housing (totally enclosed)		Aluminum
Stem		Plated steel
Diaphragm		Ozone resistant rubber
Spring		Steel
Cup		Zytel
Maximum air pressure		30 psig (210 kPa)
Type of mounting		Fixed or pivot
Thrust and torque rating		See Table 3
Agency Approvals		Complies with UL555 and UL555S
	* For special applications, an actuator stroke of 2-3/4 inch is available in 3 to 7, 5 to 10, or 8 to 13 psi (21 to 58, 35 to 69, or 55 to 90 kPa) spring ranges. Some models are UL Recognized Components under UL's Damper Actuator category (EMKU2), which covers pneumatic damper actuators intended to be employed on fire dampers and leakage rated dampers. Contact Siemens Building Technologies, Inc. National OEM Sales and Marketing for information.	

**Specifications,  
 Continued**

**Operating**

Nominal spring ranges	3 to 7 psi (21 to 50 kPa) 5 to 10 psi (35 to 69 kPa) 8 to 13 psi (55 to 90 kPa)
Operating temperature	-20°F to 160°F (-29°C to 71°C)
Air connection	Straight barb fitting for 1/4-inch OD plastic tubing installed in 1/8-inch NPT opening

**Miscellaneous**

Shipping Weight:	
Basic actuator	1.3 lb (0.58 kg)
Actuator with extended shaft mounting	3.1 lb (1.4 kg)
Actuator with fixed bracket	2.5 lb (1.1 kg)
Actuator with fixed bracket and clevis	2.7 lb (1.2 kg)
Actuator with extended shaft mounting and Positioning Relay	4.8 lb (2.2 kg)
Dimensions	See Figures 4 through 8

**Accessories**

Linkage kit, 4-inch link and crank	331-958
Linkage kit, 4-inch rod, ball joint and crank	331-947
Damper shaft crank, selectable radius, 45°, 60°, and 90°, angular rotation for 3/8 to 1/2-inch (10 to 13-mm) diameter damper shafts	331-941
Damper shaft crank, adjustable radius 3/4 to 2-7/8 inch (19 to 73 mm) for 1/2-inch (13-mm) diameter damper shafts	331-795
Damper shaft crank, adjustable radius 3/4 to 4-5/8 inch (19 to 177 mm) for 3/8-inch (9 mm) diameter damper shafts	331-805
Damper shaft extension, 1/2 x 9 inches long	333-042
Damper shaft extension, 1/2 inch shaft	331-631
Damper shaft extension Adapter, for 3/8 inch shaft	331-632
Pivot mounting kit (bracket and three mounting screws)	333-148
Pivot post	333-139
Fixed mounting bracket	331-916
Extended shaft mounting plate	331-033
Clevis, steel	333-207
Clevis, forged	331-292
Clevis pin	331-293
Clevis, frame mounting	331-653
Hitch pin	331-807
12-inch Damper actuator push rod	338-041
15-inch Damper actuator push rod	338-042
18-inch Damper actuator push rod	338-043
24-inch Damper actuator push rod	338-044
36-inch Damper actuator push rod	338-045
48-inch Damper actuator push rod	338-046
Damper blade rocker arm	333-034
Positioning relay	147-2000
Relay mounting kit	147-104

**Table 3. Thrust Torque Ratings.**

Nominal Spring Range	Maximum Thrust lb. (N)				Torque Rating* lb-in (Nm)			
	Full Stroke Forward			Spring Return (No Stroke) 0 psig (0 kPa)	Gradual Operation	2-Position Operation		
	15 psi (103 kPa)	18 psi (124 kPa)	25 psi (172 kPa)			15 psi (103 kPa)	18 psi (124 kPa)	25 psi (172 kPa)
3 to 7 psi (21 to 48 kPa)	64 (285)	88 (391)	144 (641)	24 (107)	10 (1.1)	20.2 (2.3)	20.2 (2.3)	20.2 (2.3)
5 to 10 psi (35 to 69 kPa)	40 (178)	64 (285)	120 (534)	40 (178)	10 (1.1)	33.6 (3.8)	33.6 (3.8)	33.6 (3.8)
8 to 13 psi (55 to 90 kPa)	16 (71)	40 (178)	96 (427)	64 (285)	10 (1.1)	53.8 (6.1)	53.8 (6.1)	53.8 (6.1)

\* With maximum hysteresis of 2.5 psi (17.2 kPa) @ 90° rotation.

## Sizing

The size and quantity of actuators required depends on several damper torque factors:

- Damper type (standard or low leakage)
- Quality of damper installation
- Number of damper sections
- Air velocity
- Static pressure
- Age of damper

To determine the correct actuator required for the installation:

- Obtain the damper torque ratings (lb-in/sq-ft) from the damper manufacturer.
- Determine the area of the damper.
- Calculate the total torque required to move the damper.
- Select the appropriate actuator(s).

## Installation

### Extended Shaft Mounting, Pivot Mounting

For Actuators 331-4311, 331-4511, 331-4811, or 332-4811. These assemblies are designed for 90° damper rotation.

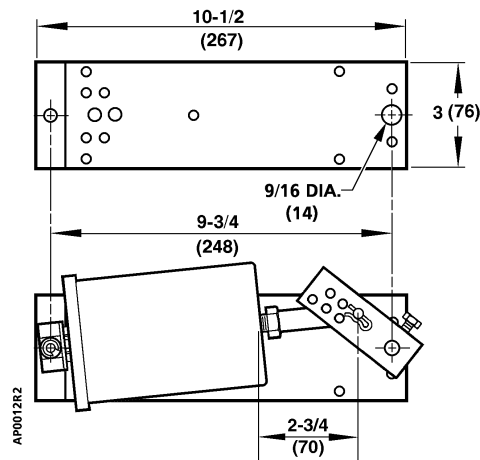
**NOTE:** Clevis mounts in Crank Radius Hole No. 6 for 90° damper rotation.

1. Slip the 9/16-inch (14 mm) diameter hole in the mounting plate over the damper shaft (Figure 1).
2. Slip the crank over the 3/8 through 1/2-inch (10 through 13-mm) diameter damper shaft (Figure 2).
3. Position the mounting plate (Table 3).
4. Attach the mounting plate to the duct with four screws.

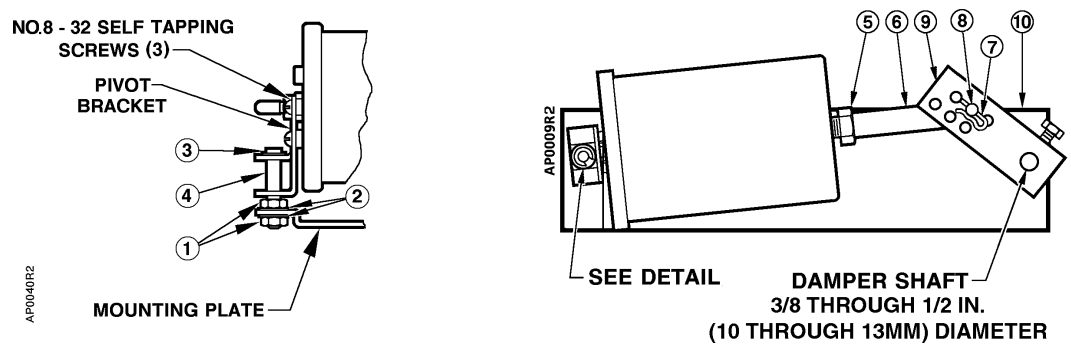
**Installation, Continued**

**Table 3. Damper Blade Rotation.**

Actuator Position in Relation to Damper Shaft	Crank Position in Relation to Damper Shaft	Rotation of Damper Blade on Increase of Pressure
Left	Above	Clockwise
	Below	Counterclockwise
Right	Above	Counterclockwise
	Below	Clockwise



**Figure 1. Mounting Plate and Extended Shaft Mounting.**



Item	Description	Item	Description
1	Nut(s)	6	Clevis
2	Lock Washers (2)	7	Hitch Pin
3	E-ring	8	Clevis Pin
4	Pivot Post	9	Crank Assembly Kit No. 331-941
5	Nut	10	Actuator Mounting Plate

**Figure 2. Extended Shaft Mounting with Pivot.**

## Installation, Continued

### Extended Shaft Mounting, Fixed Actuator

For Actuators 331-4314, 331-4514, 331-4814 order Linkage Kit 331-958.

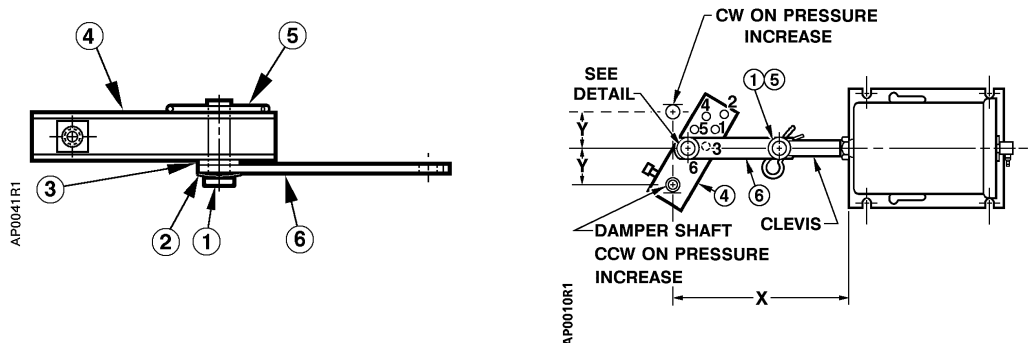
For Actuators 331-4313, 331-4513, 331-4813, order Clevis 333-207 and Linkage Kit 331-958.

1. Determine the direction of the damper shaft rotation (clockwise or counterclockwise) on an increase in pressure to the actuator.
2. Determine the angle of rotation required for the damper to move from closed to full open.

**NOTE:** Since the actuator stroke is 2-3/8 inch (6 cm) and the angle of rotation is known, the crank radius can be determined from the graph in *TB181 Maximum Thrust Ratings of Pneumatic Damper Actuators Technical Bulletin* (155-219P25) or use Table 4.

3. Attach the link to the crank at the radius value determined in Step 2.
4. Attach the clevis and other end of the linkage to the actuator shaft (Figure 3).
5. The normal position of the damper (open or closed) and its direction of rotation (CW or CCW) will determine the location of the actuator and linkage assembly (Table 3).
6. Attach an air line or Baumanometer (squeeze bulb) to the actuator and increase pressure until the actuator shaft moves one half of its stroke, 1-3/16 inch (3 cm). Select the correct location for the actuator assembly as determined in Step 5.
7. Slip the crank over the damper shaft and position the assembly so that the actuator shaft and link are straight and perpendicular to the crank.
8. Mark and attach the actuator bracket to the duct at this location. If this installation procedure is followed, there will be no problem with linkage scissoring or locking up.

The installation is complete.



Item	Description	Item	Description
1	Clevis Pin	4	Crank with Set Screw
2	Spring Washer	5	Hitch Pin
3	Washer, Nylon	6	Link, 4 inches (102 mm) long

Figure 3. Fixed Mounted Actuator Assembly with Linkage Kit 331-958.



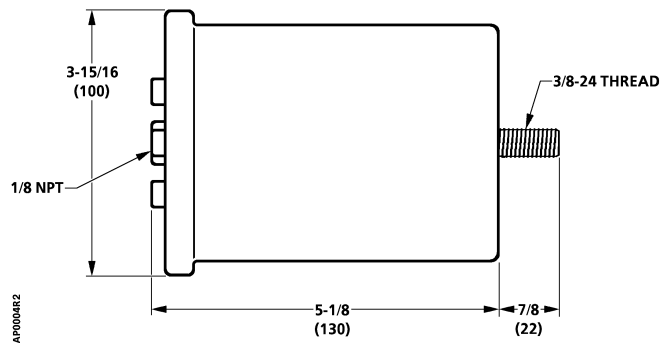
**Installation, Continued**

**Table 4. Crank Radius Connection.**

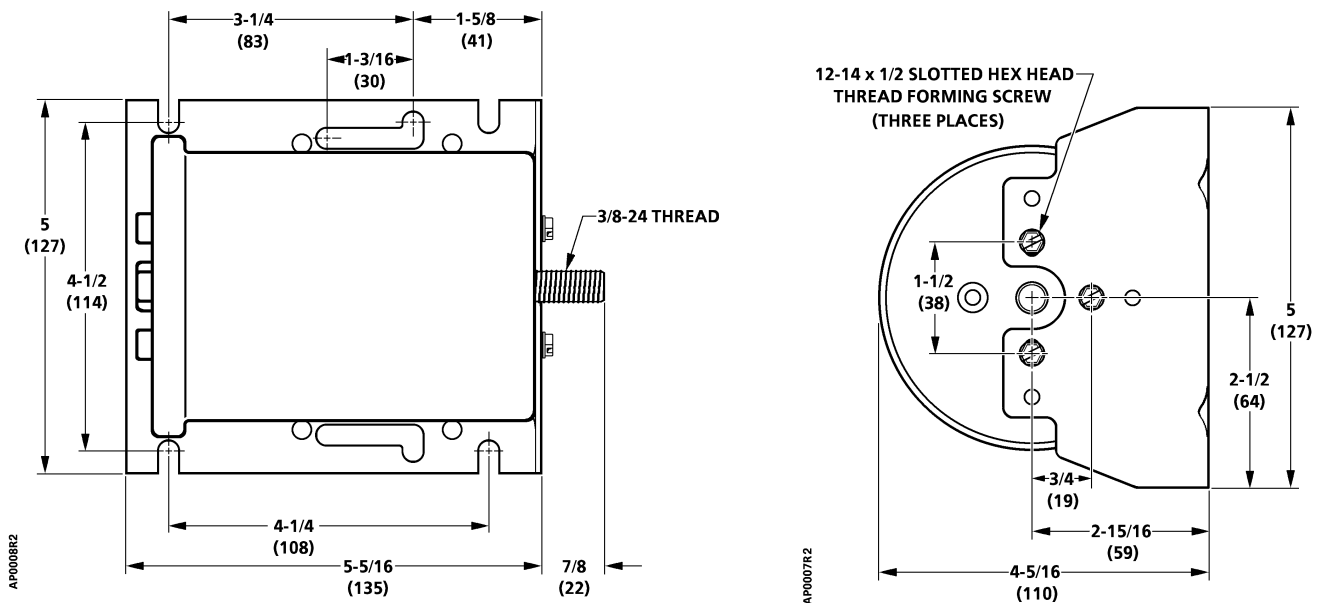
Dimensions		Application	Crank Radius Connection	Crank Hole Number
X	Y			
7-7/8 inch (200 mm)	1-3/16 inch (30 mm)	2-3/8 inch (60 mm) stroke 90 ° Rotation	1-11/16 inch (43 mm)	6
7-7/8 inch (200 mm)	2-1/16 inch (52 mm)	2-3/8 inch (60 mm) stroke 60 ° Rotation	2-3/8 inch (60 mm)	5

**NOTE:** Crank Radius Holes No. 1 through 4 are used for No. 4 and No. 6 Pneumatic Damper Actuators only.

**Dimensions**

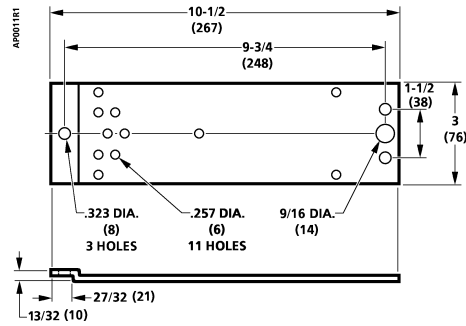


**Figure 4. No. 3 Pneumatic Damper Actuator Dimensions. Dimensions are in Inches (Millimeters).**

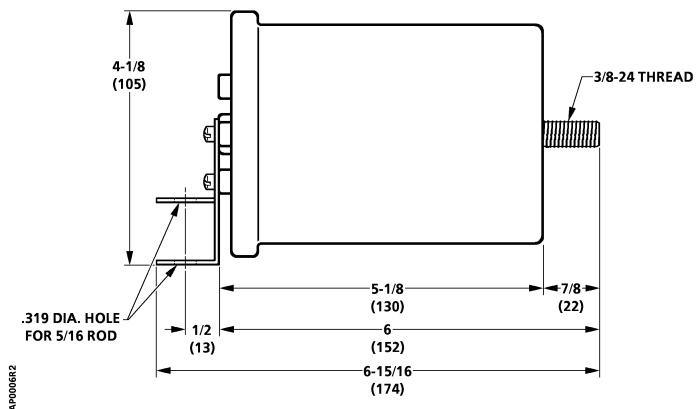
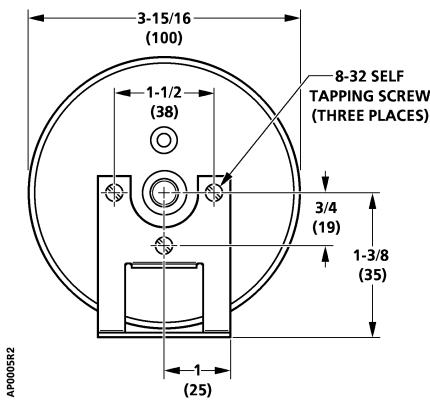


**Figure 5. No. 3 Actuator with Fixed Mounting Bracket Dimensions. Dimensions are in Inches (Millimeters).**

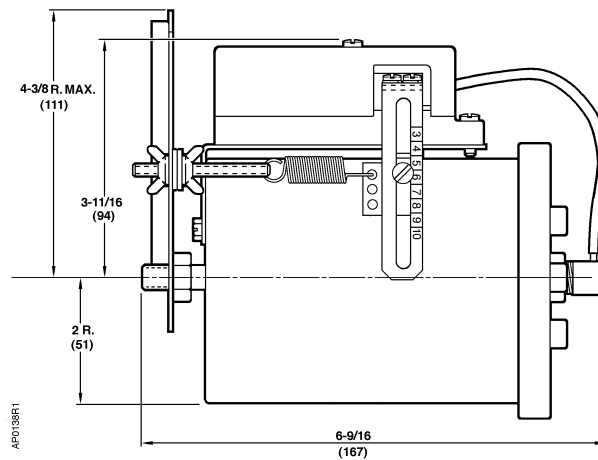
**Dimensions, Continued**



**Figure 6. Extended Shaft Mounting Bracket Dimensions. Dimensions are in Inches (Millimeters).**



**Figure 7. No. 3 Actuator with Pivot Mounting Bracket Dimensions. Dimensions are in Inches (Millimeters).**



**Figure 8. No. 3 Actuator with the RL 147 Positioning Relay Mounted Dimensions. Dimensions in Inches (Millimeters).**

Information in this publication is based on current specifications. The company reserves the right to make changes in specifications and models as design improvements are introduced. POWERS is a registered trademark of Siemens Industry, Inc. Product or company names mentioned herein may be the trademarks of their respective owners. © 2008 Siemens Industry, Inc.

## MS4104, MS4109, MS4604, MS4609, MS8104, MS8109 Fast-Acting, Two-Position Actuators FOR FIRE/SMOKE CONTROL APPLICATIONS

### PRODUCT DATA



### FEATURES

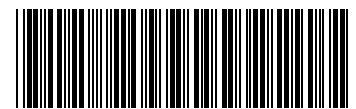
- 30 lb-in. (3.4 N•m) or 80 lb-in. (9 N•m) minimum driving torque at 350°F (176°C).
- Reversible mounting facilitates use in either clockwise (cw) or counterclockwise (ccw) spring rotation.
- Integral spring return ensures level of return torque.
- Fifteen-second spring return timing.
- No special cycling required during long-term holding. (See Operation section.)
- No audible noise during holding.
- Patent pending design eliminates need for limit switches to reduce power consumption.
- Models available for 24, 120, and 230 Vac.
- Ninety-five degree angle of rotation.
- Actuator holds rated torque at reduced power level.
- Die-cast aluminum housing.
- Housing design allows flush mounting to damper.
- Designed to operate reliably in smoke control systems requiring Underwriter's Laboratories Inc. UL555S ratings up to 350°F.
- Models available with SPST position-indicating switches (7°, 85° stroke).

### APPLICATION

The MS4104, MS4109, MS4604, MS4609, MS8104 and MS8109 Fast-Acting, Two-Position Actuators are spring return direct coupled actuators (DCA) for Fire and Smoke dampers (on/off control). The actuator accepts an on/off signal from a single-pole, single-throw (SPST) controller. Reversible mounting allows actuator to be used for either clockwise (cw) or counterclockwise (ccw) spring rotation.

### Contents

Application .....	1
Features .....	1
Specifications .....	2
Ordering Information .....	2
Installation .....	4
Operation .....	6
Checkout .....	6



63-2740-05

# SPECIFICATIONS

**Models:** See Table 1.

**Table 1. Models.**

Model	Voltage (Vac)	Internal Auxiliary Switches
MS4104F1010	120	None
MS4104F1210	120	2 SPST <sup>a</sup>
MS4109F1010	120	None
MS4109F1210	120	2 SPST <sup>a</sup>
MS4604F1010	230	None
MS4604F1210	230	2 SPST <sup>a</sup>
MS4609F1010	230	None
MS4609F1210	230	2 SPST <sup>a</sup>
MS8104F1010	24	None
MS8104F1210	24	2 SPST <sup>a</sup>
MS8109F1010	24	None
MS8109F1210	24	2 SPST <sup>a</sup>

<sup>a</sup> Internal switches are designed to pass UL555S requirements (at 350°F for 30 minutes) and are intended for use as position indication.

**Dimensions:** See Fig. 1.

**Minimum Damper Shaft Length:** 2 in. (51 mm).

**Device Weight:** 5 lb (2.3 kg).

**Stroke:** 95° ± 3°, mechanically limited.

**Electrical Ratings:** See Table 2.

**Electrical Connections:**

Power Lead Wires:

MS410xF and MS460xF: 32 inches (0.8m), 18 AWG

MS810xF: 39 inches (1m), 18 AWG

**Switch Lead Wires:** 18 inches, 18 AWG, 2 color coded leads

**Mounting:** Round 1/2 inch shaft adapter with 1/4 inch set screws.

Threads: ¼-20 UNC-2A

Material: Alloy Steel hardened to HRC 45-53

Thread Lock: Nylon Patch

**IMPORTANT**

*Honeywell does not recommend using linkages with these actuators because side-loading of the output hub reduces actuator life.*

**Temperature Ratings:**

Ambient: 0°F to 130°F (-18°C to 55°C).

Shipping and Storage: -40°F to 140°F (-40°C to 60°C).

**IMPORTANT**

*The actuator is designed to meet UL555S standards at 350°F (176°C). The actuator must be tested with the damper to achieve this rating.*

**Humidity Ratings:** 5% to 95% RH noncondensing.

**Noise Rating (Maximum):**

Driving Open: 75 dBA at 1m.

Holding: 20 dBA at 1m (no audible noise).

**Controller Type:**

MS4104, MS4109: Line voltage (120 Vac), two-position, SPST (Series 40).

MS4604, MS4609: Line voltage (230 Vac), two-position, SPST (Series 40).

MS8104, MS8109: Low voltage (24 Vac), two-position, SPST (Series 80).

**Table 2. MS4104, MS4109, MS4604, MS4609, MS8104 and MS8109 DCA Models.**

Model	Power Consumption		Torque in lb-in. (N•m)	Voltage Input in Vac
	Running	Holding		
MS4104F	0.18A, 18W	0.11A, 9W	30 (3.4)	120 ±10%, 50/60 Hz
MS4109F	0.25A, 23W	0.13A, 7W	80 (9)	
MS4604F	0.13A, 18W	0.10A, 11W	30 (3.4)	230 ±10%, 50/60 Hz
MS4609F	0.13A, 23W	0.09A, 7W	80 (9)	
MS8104F	16 VA	8 VA	30 (3.4)	24Vac/dc +20%, -10%, 50/60 Hz
MS8109F	23 VA	7 VA	80 (9)	

# ORDERING INFORMATION

When purchasing replacement and modernization products from your TRADELINE® wholesaler or distributor, refer to the TRADELINE® Catalog or price sheets for complete ordering number. If you have additional questions, need further information, or would like to comment on our products or services, please write or phone:

1. Your local Honeywell Environmental and Combustion Controls Sales Office (check white pages of your phone directory).
2. Honeywell Customer Care  
1985 Douglas Drive North  
Minneapolis, Minnesota 55422-4386
3. <http://customer.honeywell.com> or <http://customer.honeywell.ca>

International Sales and Service Offices in all principal cities of the world. Manufacturing in Belgium, Canada, China, Czech Republic, Germany, Hungary, Italy, Mexico, Netherlands, United Kingdom, and United States.

**Torque Rating (at rated voltage):**

**Spring Return:**

MS4104F, MS4604F, MS8104F: 30 lb-in. (3.4 N•m).  
 MS4109F, MS4609F, MS8109: 80 lb-in. (9 N•m).

**Stall Maximum:**

MS4104F, MS4604F, MS8104F: 150 lb-in. (17 N•m).  
 MS4109F, MS4609F, MS8109: 240 lb-in. (27 N•m).

**350°F Driving:**

MS4104F, MS4604F, MS8104F: 30 lb-in. (3.4 N•m).  
 MS4109F, MS4609F, MS8109: 80 lb-in. (9 N•m).

**Timing (At Rated Torque and Voltage):**

Drive Open: 15 seconds typical.  
 Spring Close: 15 seconds typical.

**Cycling Requirements:**

The actuator and the internal spring are designed to require no special cycling during long-term holding.

Honeywell recommends following all local, state and national codes for periodic testing of the entire smoke control system. Refer to National Fire Protection Association (NFPA) National Fire Codes®: NFPA90A, NFPA92A and NFPA92B for your application.

NFPA recommends periodic examination of each fire/smoke damper (semi-annually or annually) to ensure proper performance.

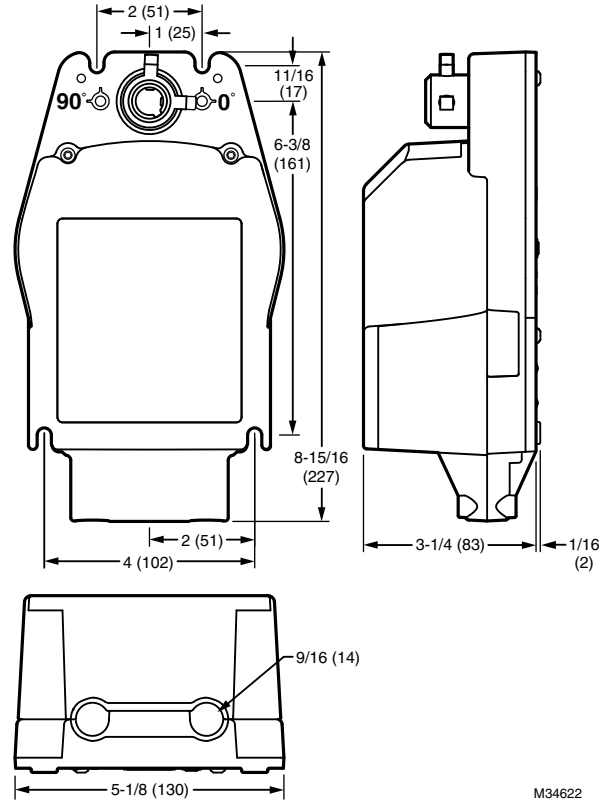
**Design Life (at Rated Voltage):** 30,000 full stroke cycles.

**Approvals:** See Table 3.

**Environmental Protection Ratings:** See Table 4.

**Accessories:**

205649 Mounting Bracket (not supplied with actuator).



**Fig. 1. MS4104, MS4109, MS4604, MS4609, MS8104 and MS8109 dimensional drawing in in. (mm).**

**Table 3. Approvals.**

	MS4104F, MS4109F	MS4604F, MS4609F	MS8104F, MS8109F
UL/cUL	X	X	X
UL60730	X	X	X
CE	X	X	X
C-Tick	X	X	X

**Table 4. Environmental Ratings.**

All Devices	MS4104, MS4109, MS4604, MS4609, MS8104 and MS8109
NEMA1	IP40

# INSTALLATION

## When Installing this Product...

1. Read these instructions carefully. Failure to follow them could damage the product or cause a hazardous condition.
2. Check the ratings given in the instructions and on the product to make sure the product is suitable for your application.
3. Installer must be a trained, experienced service technician.
4. After installation is complete, check out product operation as provided in these instructions.

**IMPORTANT**

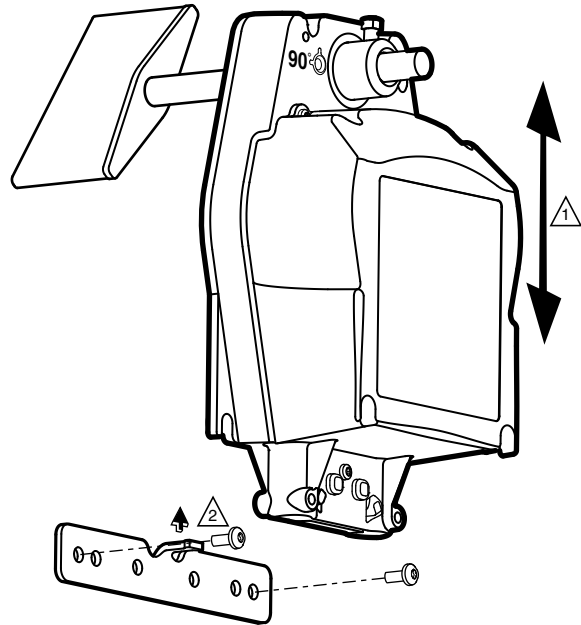
*All wiring must agree with applicable codes, ordinances and regulations.*

### **WARNING**

**Electrical Power Hazard.**  
**Line voltage can cause death or serious injury and short equipment circuitry.**  
 Disconnect power supply before installation.

### **CAUTION**

**Electrical Shock or Equipment Damage Hazard.**  
**Low voltage can shock individuals or short equipment circuitry.**  
 Disconnect power supply before installation.





**1** ENSURE THAT MOUNTING ASSEMBLY PREVENTS ACTUATOR ROTATION AND ALLOWS ACTUATOR TO FLOAT ALONG INDICATED AXIS. WHEN TOO TIGHT, THE RESULTING BINDING CAN DAMAGE THE ACTUATOR OR REDUCE TORQUE OUTPUT.

**2** ACCESSORY MOUNTING BRACKET IS NOT SUPPLIED WITH THE ACTUATOR.

M34623

**Fig. 2. Mounting actuator to damper housing.**

## Location and Mounting

The actuators are designed to open a damper by driving the damper shaft in either clockwise  or counterclockwise  direction. The actuator housing has two slots on the bottom that, with a 205649 Mounting Bracket, secure it flush to a damper box (see Fig. 2). When mounted correctly, these slots allow the actuator to *float* without rotating relative to the damper shaft.

### **CAUTION**

**Equipment Damage Hazard.**  
**Tightly securing actuator to damper housing can damage actuator.**  
 Mount actuator to allow it to float along its vertical axis.

## Preparation

Before mounting the actuator onto the damper shaft, determine the:

- Damper/valve opening direction for correct spring return rotation. The actuator can be mounted to provide clockwise or counterclockwise spring return.
- Damper shaft size (see Specifications section).

## Installation



### CAUTION

**Device Malfunction Hazard.**  
**Improper set screw tightening causes device malfunction.**

Ensure damper blade is in the correct position and tighten set screws with proper torque to prevent damper shaft slippage.



### CAUTION

**Actuator Damage Hazard.**  
**Using actuator as shaft bearing causes device damage.**

Use actuator only to supply rotational torque. Avoid any side loads to actuator output coupling bearings.

To install actuator, proceed as follows:

1. Place actuator over damper shaft; and hold mounting bracket in place. See Fig. 2.
2. Mark screw holes on damper housing.
3. Remove actuator and mounting bracket.
4. Drill or center-punch holes for mounting screws (or use no.10 self-tapping sheet metal screws).
5. Turn damper blades to desired normal (closed) position.
6. Place actuator and mounting bracket back into position and secure bracket to damper box with sheet metal screws.
7. Tighten set screws securely into damper shaft using minimum 100 lb-in., maximum 130 lb-in. torque. Use 1/4 in. wrench (see Specifications for details) to tighten set screws.

## Wiring

See Fig. 3 through 5 for typical wiring diagrams.



### WARNING

**Electrical Power Hazard.**  
**Line voltage can cause death or serious injury and short equipment circuitry.**

Disconnect power supply before installation.



### CAUTION

**Electrical Shock or Equipment Damage Hazard.**  
**Low voltage can shock individuals or short equipment circuitry.**

Disconnect power supply before installation.

### IMPORTANT

1. All wiring must comply with local electrical codes, ordinances and regulations.
2. Voltage and frequency of transformer must correspond with the characteristics of power supply and actuator.
3. Use wires rated for at least 75°C (167°F).
4. The conduit fittings are designed for use with 3/8 in. reduced-wall steel or aluminum flexible conduit.

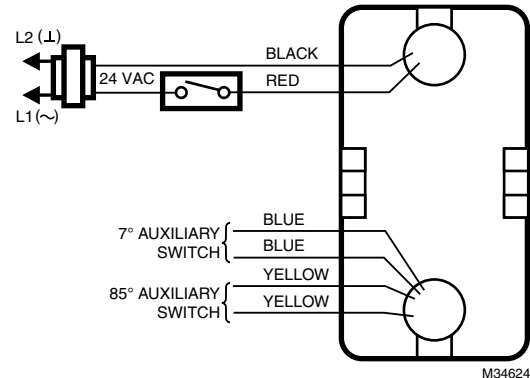


Fig. 3. Typical 24 Vac wiring.

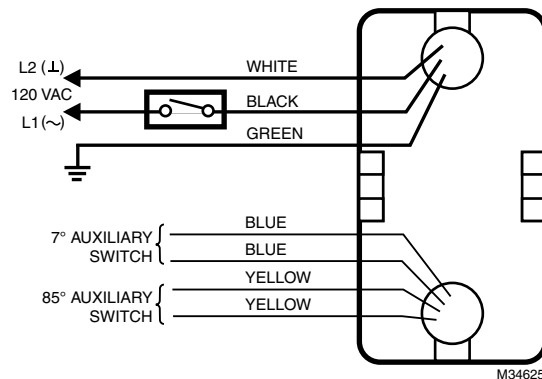


Fig. 4. Typical 120 Vac wiring.

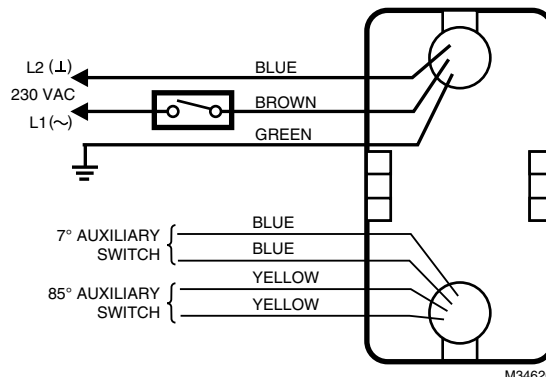


Fig. 5. Typical 230 Vac wiring.



## OPERATION

The MS4104, MS4109, MS4604, MS4609, MS8104 and MS8109 DCA are designed for use in Smoke Control Systems. If power fails, the actuator spring returns to the 0° position. The actuator mounts flush with the damper box. The actuator drives from 0° to 95° and spring returns back to 0°.

The actuators are operated by an spst two-position controller. When using an spst two-position controller, the actuator drives to the damper fully open position when controller contact makes and spring returns to the damper fully closed position when controller contact breaks. The actuator drops to holding power level on detection of stall, independent of hub position.

### Cycling

The actuator and the internal spring are designed so that no special cycling during long-term holding is required. Honeywell recommends following all local, state, and national codes for periodic testing of the entire smoke control system. Refer to National Fire Protection Association (NFPA) National Fire Codes®: NFPA90A, NFPA92A, and NFPA92B for your application.

**NOTE:** The actuator is designed to operate for 30 minutes during a one-time excursion to 350°F (176°C).

## CHECKOUT

### MS4104F, MS4109F (120 Vac model)

1. Check damper position.
2. Connect 120 Vac to the black and white leadwires to drive the damper to the open position. The actuator should drive the damper.
3. If the actuator does not spring return, verify that the actuator is properly installed. See Installation section.
4. If the actuator is correctly installed but neither runs nor spring returns, replace the actuator.

### MS4604F, MS4609F (230 Vac model)

1. Check damper position.
2. Connect 230 Vac to the blue and brown leadwires to drive the damper to the open position. The actuator should drive the damper.
3. If the actuator does not spring return, verify that the actuator is properly installed. See Installation section.
4. If the actuator is correctly installed but neither runs nor spring returns, replace the actuator.

### MS8104F, MS8109F (24 Vac model)

1. Check damper position.
2. Connect 24 Vac to the red and black leadwires to drive the damper to the open position. The actuator should drive the damper.
3. If the actuator does not spring return, verify that the actuator is properly installed. See Installation section.
4. If the actuator is correctly installed but neither runs nor spring returns, replace the actuator.

*National Fire Codes® is a registered trademark of the National Fire Protection Association (NFPA).*



**Automation and Control Solutions**

Honeywell International Inc.  
1985 Douglas Drive North  
Golden Valley, MN 55422  
[customer.honeywell.com](http://customer.honeywell.com)

© U.S. Registered Trademark  
© 2013 Honeywell International Inc.  
63-2740—05 M.S. Rev. 12-13  
Printed in United States

**Honeywell**



**DUAL TEMPERATURE OVERRIDE SENSOR**  
**REOPENABLE CONTROL SYSTEM WITH HIGH LIMIT**  
**FOR COMBINATION FIRE / SMOKE DAMPERS**  
**MODEL: DTO FIRE SENSOR**

The DTO Dual Temperature Override Sensor is a factory installed option on Nailor combination fire/smoke dampers, incorporating two electric heat sensors (with external manual reset buttons). A primary heat sensor (manual reset) automatically closes the damper upon sensing an elevated temperature of 165°F (74°C) at the damper. The sensor interrupts power to the actuator, and the actuator's spring return mechanism causes the damper to close. The damper may be closed at anytime by placing a control switch (by others) in the closed position.

The primary heat sensor and the smoke detector (if used) can be bypassed by an external electrical signal from a remote control station, allowing the damper to reopen as may be required in the operation of a smoke control system. The Fire Fighter's Smoke-Control Station must include a three position (double throw, center off) master switch for correct operation.

The damper remains operational until the the temperature at the damper reaches that of the high limit secondary heat sensor. This is the UL listed elevated/degradation temperature rating (operational limit) of the damper/actuator assembly. The standard high limit temperature is 250°F (121°C). A 350°F (177°C) elevated temperature classification is available as an option. When the temperature of the high limit heat sensor is exceeded, the damper closes and locks and remains closed thereafter, in conformance with UL 555 and NFPA 90A. The secondary sensor can be manually reset, using the external button, at the damper after temperatures have cooled down.

The DTO can be ordered with electric (120 or 24 Vac) or pneumatic actuators. Pneumatic actuators are supplied with a factory mounted EP (electric/pneumatic) switch.

The DTO Fire Sensor also incorporates a position indicator package. Two auxiliary switches indicate the open and closed damper position at a remote control station.

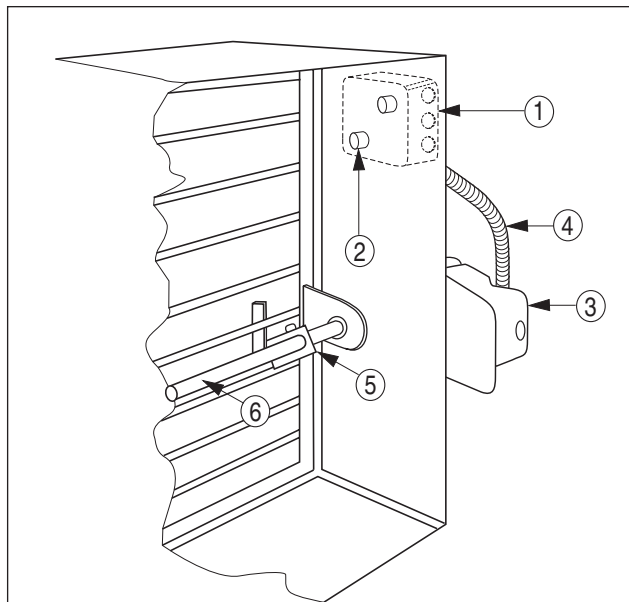
For installation and operation instructions, see dwg. IOM-DTO.

**NOTE:**

Nailor recommends the use of a single ERL Electric Resettable Link at the elevated/degradation temperature of the damper/actuator assembly on all combination fire/smoke dampers. 250°F Standard (350°F optional). Together with a position indicator package (MLS-300) where remote damper position status is required.

The re-openable system only provides a narrow temperature window of operation, increased cost and complexity of operation, since UL555 introduced the high limit closure requirement in 1995 in full compliance with the intent of NFPA 90A.

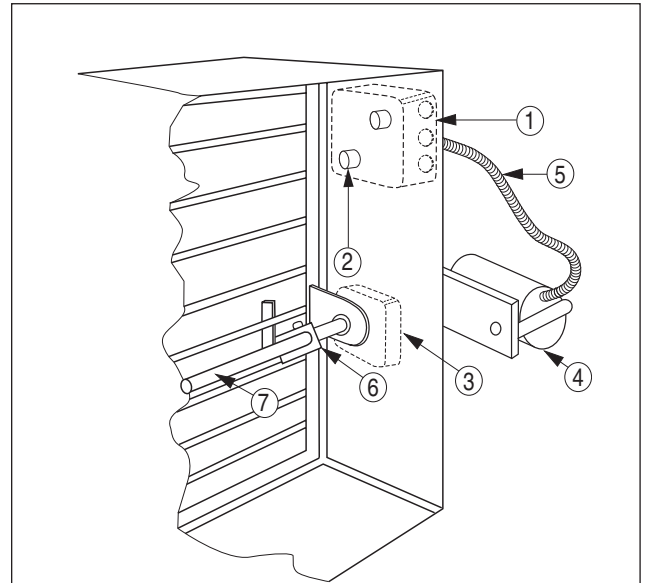
Previous building codes used to require 165°F (74°C) for all fire dampers. This is no longer the case for Smoke Management Systems.



**With UL Listed Electric Actuator**  
**Description:**

1. Electrical Junction Box with 165°F (74°C) Primary Heat Sensor
2. High Limit Secondary Heat Sensor 250°F or 350°F (121°C or 177°C)
3. Electric Actuator with Auxiliary Position Indicator Switches
4. Flexible Conduit
5. Over-Center Knee Lock
6. Jackshaft

<b>SCHEDULE TYPE:</b>	Page 1 of 2			
<b>PROJECT:</b>	Dimensions are in inches (mm)			
<b>ENGINEER:</b>	<b>DATE</b>	<b>B SERIES</b>	<b>SUPERSEDES</b>	<b>DRAWING NO.</b>
<b>CONTRACTOR:</b>	9 - 8 - 20	FD-ACC	MLS-400/7-20-19	DTO



**With UL Listed Pneumatic Actuator**  
**Description:**

1. Electrical Junction Box with 165°F (74°C) Primary Heat Sensor and EP Switch
2. High Limit Secondary Heat Sensor 250°F or 350°F (121°C or 177°C)
3. Position Indicator Package
4. Pneumatic Actuator
5. Silicone Tubing
6. Over-Center Knee Lock
7. Jackshaft

<b>SCHEDULE TYPE:</b>	Page 2 of 2			
<b>PROJECT:</b>	Dimensions are in inches (mm)			
<b>ENGINEER:</b>	<b>DATE</b>	<b>B SERIES</b>	<b>SUPERSEDES</b>	<b>DRAWING NO.</b>
<b>CONTRACTOR:</b>	9 - 8 - 20	FD-ACC	MLS-400/7-20-19	DTO

# FSLF120 US

On/Off, Spring Return, 350°F [177°C] for a half hour, 15 Seconds Cycle Time



## Technical Data

Power Supply	120 VAC, ±10%, 50/60 Hz
Power consumption in operation	18 VA
Power consumption in rest position	4 W, 5.5 VA (50 Hz 8 VA), End stop 27 VA, 0.25 A slow blow fuse *
Shaft Diameter	3/8" to 1/2" round, centers on 1/2"
Electrical Connection	3 ft [1 m], 18 GA appliance cable with 1/2" conduit connector
Overload Protection	electronic throughout 0° to 95° rotation
Electrical Protection	grounded enclosure, 120V
Angle of rotation	95°
Torque motor	30 in-lb [3.5 Nm] from 32...350°F [0...177°C]
direction of rotation motor	reversible with CW/CCW mounting
direction of rotation spring-return	reversible with CW/CCW mounting
Position indication	visual indicator, 0° to 95° (0° is full spring return position)
Running time motor	<15 sec at rated voltage and torque 32...122°F [0...50°C]
Running time emergency control position	<15 sec
Ambient humidity	5 to 95% RH non-condensing
Ambient temperature	32...122°F [0...50°C]
Non-operating temperature	-40...176°F [-40...80°C]
Degree of Protection	IP30, NEMA 1
Housing material	zinc coated steel
Agency Listing	cULus acc. to UL60730-1A/-2-14, CAN/CSA E60730-1:02, Listed to UL 2043 - suitable for use in air plenums per Section 300.22(C) of the NEC and Section 602 of the IMC. NYC Department of Buildings MEA 197-07-M California State Fire Marshal Listing 3210-1593:102
Noise Level (Fail-Safe)	45 dB (A) motor, 62 dB (A) spring, inaudible holding
Maintenance	maintenance free
Quality Standard	ISO 9001
Weight	4.13 lb [1.8 kg]

† UL File XAPX.E108966

## Fire & Smoke damper actuator

### Application

The type FSLF spring-return actuator is intended for the operation of smoke and combination fire and smoke dampers in ventilation and air-conditioning systems. The actuator will meet requirements of UL555 and UL555S when tested as an assembly with the damper and will meet requirements of UBC for 15 second opening and closing. Square footage of damper operated will depend on make and model and the temperature required.

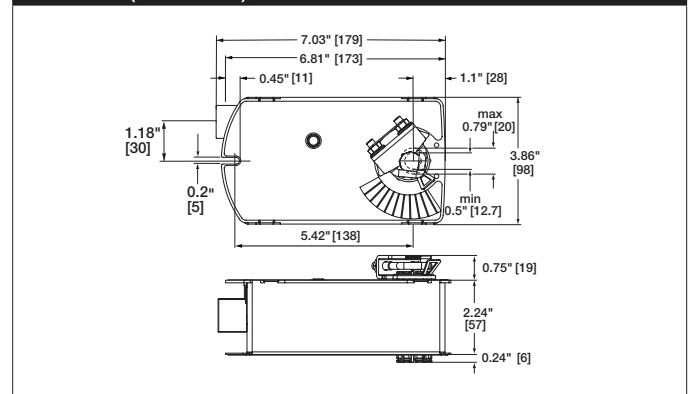
**IMPORTANT 24VDC NOTE:** The FSLF24 & -S models will not operate below 24VDC. A filtered and regulated power supply must be used.

### Operation

Mounting of the actuator to the damper axle shaft or jackshaft is via a cold-weld clamp. Teeth in the clamp and V-bolt dig into the metal of both solid and hollow shafts maintaining a perfect connection. The specially designed clamp will not crush hollow shafts. The bottom end of the actuator is held by an anti-rotation strap or by a stud provided by the damper manufacturer.

The actuator is mounted in its fail safe position with the damper blade(s) closed. Upon applying power, the actuator drives the damper to the open position. The internal spring is tensioned at the same time. If the power supply is interrupted, the spring moves the damper back to its fail-safe position.

### Dimensions (Inches[mm])



### Safety Notes

\* Neither UL nor Belimo require individual fusing of FSLF actuators.

The FSLF draws higher peak current when driving against its end stop or any other type of stop. Given the technology of fuses & breakers, this requires the value of fuse or breaker to be increased to avoid nuisance opening or tripping. A 1 amp slow blow should be used for 24VAC. A 0.25 amp slow blow should be used for 120VAC. A .125 amp slow blow should be used for 230V.

#### SAFETY NOTES

Wiring and installation must comply with all local electrical and mechanical codes.

The actuator contains no components which the user can replace or repair. Cables are not plenum rated and require flex conduit.

1/2" Threaded Connector: Screw a conduit fitting into the actuator's metal bushing. Jacket the actuator's input wiring with suitable flexible conduit. Properly terminate the conduit in a suitable junction box.

3/8" Flex Connector (-FC models): Mount the flexible conduit into the actuator's metal bushing by means of the provided screw with a torque of 1.2 Nm. Jacket the actuator's input wiring with suitable flexible conduit. Properly terminate the conduit in a suitable junction box.

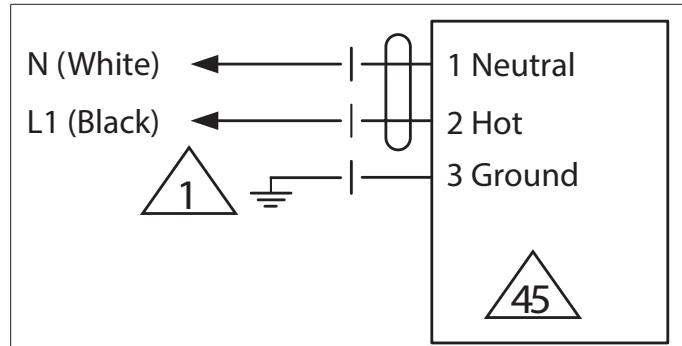
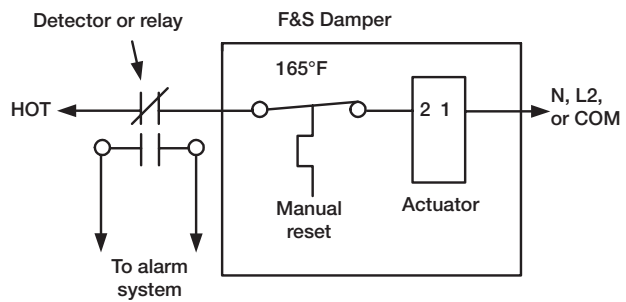
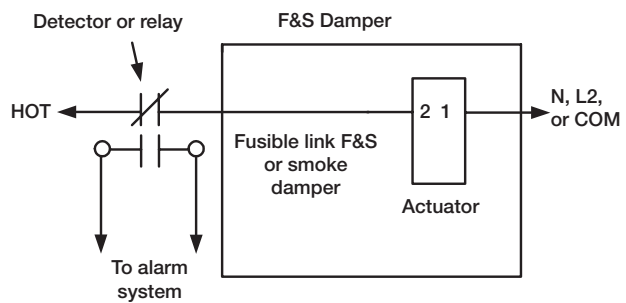
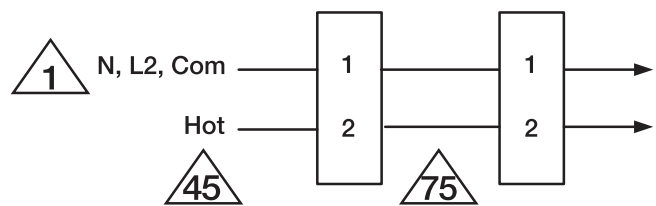
Accessories	
---BAE165 US	165° F electric thermal sensor, SPST, normally closed.
---S2A-F US	Auxiliary switch, 2x SPDT, 3A (0.5A inductive) @250 VAC max.

**Typical Specification**

All smoke and combination fire and smoke dampers shall be provided with Belimo FSTF, FSLF, FSNF, or FSAF actuators. All substitutions must be approved before submission of bid. Damper and actuator shall have UL 555S Listing for 250°F (350°F). Actuator shall have been tested to UL 2043 per requirements of IMC 602.2 and NEC 300.22 (c). Where position indication is required -S models with auxiliary switches or damper blade switches will be provided per code requirements.

**Wiring Diagrams**
**APPLICATION NOTES**

- Provide overload protection and disconnect as required.
- Actuators may be powered in parallel. Power consumption must be observed.
- Ground present on some models.


**120 VAC**

**Typical containment damper control wiring**

**Typical smoke or fusible link damper wiring**

**Parallel Actuator Wiring**



# FSLF230 US

On/Off, Spring Return, 350°F [177°C] for a half hour, 15 Seconds Cycle Time



## Technical Data

Power Supply	230 VAC, ±10%, 50/60 Hz
Power consumption in operation	17 VA
Power consumption in rest position	4 W, 8 VA (60 Hz 5.5 VA), End stop 27 VA, 0.125 A slow blow fuse *
Shaft Diameter	3/8" to 1/2" round, centers on 1/2"
Electrical Connection	3 ft [1 m], 18 GA, 3 color coded leads
Overload Protection	electronic throughout 0° to 95° rotation
Electrical Protection	grounded enclosure, 230V
Angle of rotation	95°
Torque motor	30 in-lb [3.5 Nm] from 32...350°F [0...177°C]
direction of rotation motor	reversible with CW/CCW mounting
direction of rotation spring-return	reversible with CW/CCW mounting
Position indication	visual indicator, 0° to 95° (0° is full spring return position)
Running time motor	<15 sec at rated voltage and torque 32...122°F [0...50°C]
Running time emergency control position	<15 sec
Ambient humidity	5 to 95% RH non-condensing
Ambient temperature	32...122°F [0...50°C]
Non-operating temperature	-40...176°F [-40...80°C]
Degree of Protection	IP30, NEMA 1
Housing material	zinc coated steel
Agency Listing	cULus acc. to UL60730-1A/-2-14, CAN/CSA E60730-1:02, Listed to UL 2043 - suitable for use in air plenums per Section 300.22(C) of the NEC and Section 602 of the IMC. NYC Department of Buildings MEA 197-07-M California State Fire Marshal Listing 3210-1593:102
Noise Level (Fail-Safe)	45 dB (A) motor, 62 dB (A) spring, inaudible holding
Maintenance	maintenance free
Quality Standard	ISO 9001
Weight	4.12 lb [1.8 kg]

† UL File XAPX.E108966

## Fire & Smoke damper actuator

### Application

The type FSLF spring-return actuator is intended for the operation of smoke and combination fire and smoke dampers in ventilation and air-conditioning systems. The actuator will meet requirements of UL555 and UL555S when tested as an assembly with the damper and will meet requirements of UBC for 15 second opening and closing. Square footage of damper operated will depend on make and model and the temperature required.

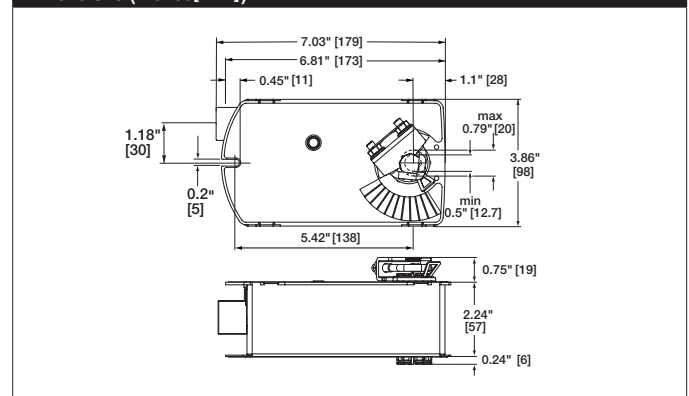
**IMPORTANT 24VDC NOTE:** The FSLF24 & -S models will not operate below 24VDC. A filtered and regulated power supply must be used.

### Operation

Mounting of the actuator to the damper axle shaft or jackshaft is via a cold-weld clamp. Teeth in the clamp and V-bolt dig into the metal of both solid and hollow shafts maintaining a perfect connection. The specially designed clamp will not crush hollow shafts. The bottom end of the actuator is held by an anti-rotation strap or by a stud provided by the damper manufacturer.

The actuator is mounted in its fail safe position with the damper blade(s) closed. Upon applying power, the actuator drives the damper to the open position. The internal spring is tensioned at the same time. If the power supply is interrupted, the spring moves the damper back to its fail-safe position.

## Dimensions (Inches[mm])



## Safety Notes

\* Neither UL nor Belimo require individual fusing of FSLF actuators.

The FSLF draws higher peak current when driving against its end stop or any other type of stop. Given the technology of fuses & breakers, this requires the value of fuse or breaker to be increased to avoid nuisance opening or tripping. A 1 amp slow blow should be used for 24VAC. A 0.25 amp slow blow should be used for 120VAC. A 1.125 amp slow blow should be used for 230V.

### SAFETY NOTES

Wiring and installation must comply with all local electrical and mechanical codes.

The actuator contains no components which the user can replace or repair. Cables are not plenum rated and require flex conduit.

1/2" Threaded Connector: Screw a conduit fitting into the actuator's metal bushing. Jacket the actuator's input wiring with suitable flexible conduit. Properly terminate the conduit in a suitable junction box.

3/8" Flex Connector (-FC models): Mount the flexible conduit into the actuator's metal bushing by means of the provided screw with a torque of 1.2 Nm. Jacket the actuator's input wiring with suitable flexible conduit. Properly terminate the conduit in a suitable junction box.

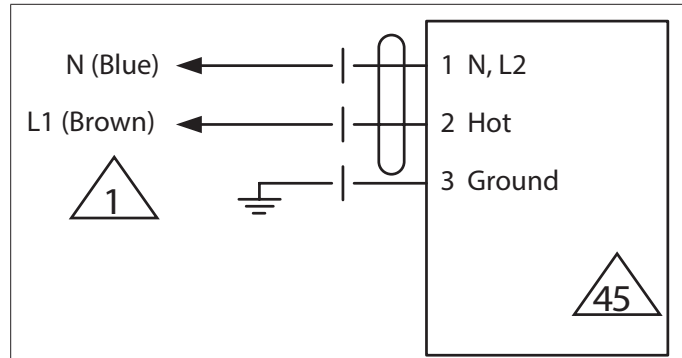
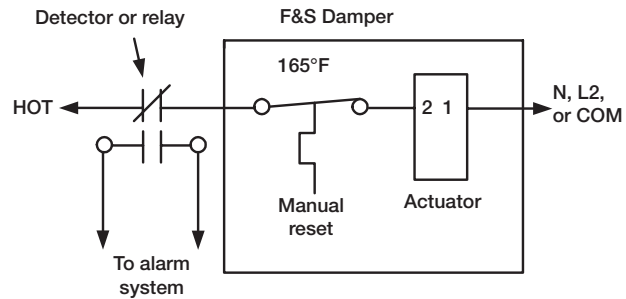
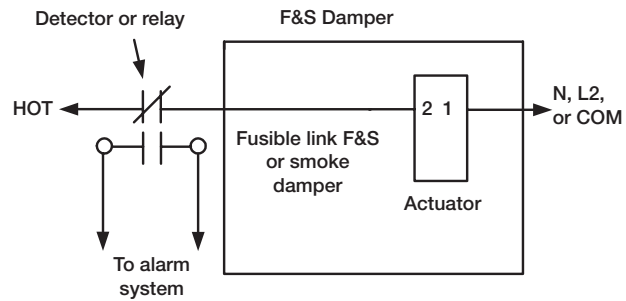
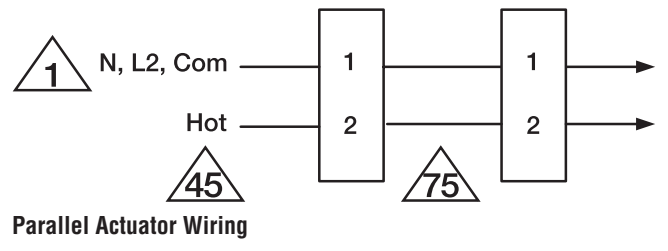
Accessories	
---BAE165 US	165° F electric thermal sensor, SPST, normally closed.
---S2A-F US	Auxiliary switch, 2x SPDT, 3A (0.5A inductive) @250 VAC max.

**Typical Specification**

All smoke and combination fire and smoke dampers shall be provided with Belimo FSTF, FSLF, FSNF, or FSAF actuators. All substitutions must be approved before submission of bid. Damper and actuator shall have UL 555S Listing for 250°F (350°F). Actuator shall have been tested to UL 2043 per requirements of IMC 602.2 and NEC 300.22 (c). Where position indication is required -S models with auxiliary switches or damper blade switches will be provided per code requirements.

**Wiring Diagrams**
**APPLICATION NOTES**

- Provide overload protection and disconnect as required.
- Actuators may be powered in parallel. Power consumption must be observed.
- Ground present on some models.


**230 VAC**

**Typical containment damper control wiring**

**Typical smoke or fusible link damper wiring**

**Parallel Actuator Wiring**

# FSLF24 US

On/Off, Spring Return, 350°F [177°C] for a half hour, 15 Seconds Cycle Time



## Technical Data

Power Supply	24 VAC, ±10%, 50/60 Hz, 24 VDC, -0% / +50%
Power consumption in operation	15 VA
Power consumption in rest position	2.5 W, 3.5 VA, End stop 25 VA, 1 A slow blow fuse *
Transformer sizing	24 VA (class 2 power source)
Shaft Diameter	3/8" to 1/2" round, centers on 1/2"
Electrical Connection	3 ft [1 m], 18 GA, 2 color coded leads
Overload Protection	electronic throughout 0° to 95° rotation
Electrical Protection	actuators are double insulated
Angle of rotation	95°
Torque motor	30 in-lb [3.5 Nm] from 32...350°F [0...177°C]
direction of rotation motor	reversible with CW/CCW mounting
direction of rotation spring-return	reversible with CW/CCW mounting
Position indication	visual indicator, 0° to 95° (0° is full spring return position)
Running time motor	<15 sec at rated voltage and torque 32...122°F [0...50°C]
Running time emergency control position	<15 sec
Ambient humidity	5 to 95% RH non-condensing
Ambient temperature	32...122°F [0...50°C]
Non-operating temperature	-40...176°F [-40...80°C]
Degree of Protection	IP30, NEMA 1
Housing material	zinc coated steel
Agency Listing	cULus acc. to UL60730-1A/-2-14, CAN/CSA E60730-1:02, Listed to UL 2043 - suitable for use in air plenums per Section 300.22(C) of the NEC and Section 602 of the IMC. NYC Department of Buildings MEA 197-07-M California State Fire Marshal Listing 3210-1593:102
Noise Level (Fail-Safe)	45 dB (A) motor, 62 dB (A) spring, inaudible holding
Maintenance	maintenance free
Quality Standard	ISO 9001
Weight	3.46 lb [1.7 kg]

† UL File XAPX.E108966

## Fire & Smoke damper actuator

### Application

The type FSLF spring-return actuator is intended for the operation of smoke and combination fire and smoke dampers in ventilation and air-conditioning systems. The actuator will meet requirements of UL555 and UL555S when tested as an assembly with the damper and will meet requirements of UBC for 15 second opening and closing. Square footage of damper operated will depend on make and model and the temperature required.

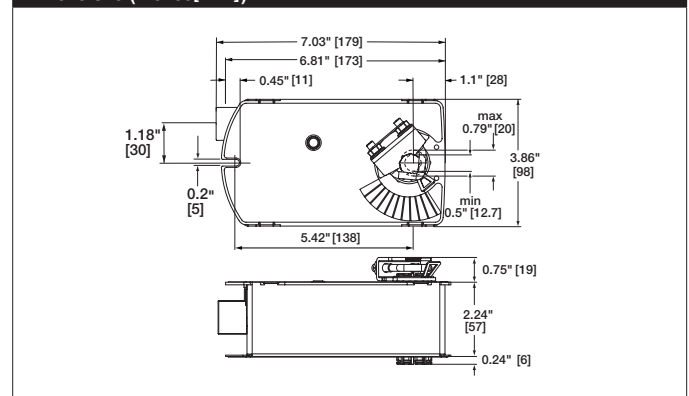
**IMPORTANT 24VDC NOTE:** The FSLF24 & -S models will not operate below 24VDC. A filtered and regulated power supply must be used.

### Operation

Mounting of the actuator to the damper axle shaft or jackshaft is via a cold-weld clamp. Teeth in the clamp and V-bolt dig into the metal of both solid and hollow shafts maintaining a perfect connection. The specially designed clamp will not crush hollow shafts. The bottom end of the actuator is held by an anti-rotation strap or by a stud provided by the damper manufacturer.

The actuator is mounted in its fail safe position with the damper blade(s) closed. Upon applying power, the actuator drives the damper to the open position. The internal spring is tensioned at the same time. If the power supply is interrupted, the spring moves the damper back to its fail-safe position.

## Dimensions (Inches[mm])



## Safety Notes

\* Neither UL nor Belimo require individual fusing of FSLF actuators.

The FSLF draws higher peak current when driving against its end stop or any other type of stop. Given the technology of fuses & breakers, this requires the value of fuse or breaker to be increased to avoid nuisance opening or tripping. A 1 amp slow blow should be used for 24VAC. A 0.25 amp slow blow should be used for 120VAC. A .125 amp slow blow should be used for 230V.

### SAFETY NOTES

Wiring and installation must comply with all local electrical and mechanical codes.

The actuator contains no components which the user can replace or repair. Cables are not plenum rated and require flex conduit.

1/2" Threaded Connector: Screw a conduit fitting into the actuator's metal bushing. Jacket the actuator's input wiring with suitable flexible conduit.

Properly terminate the conduit in a suitable junction box.

3/8" Flex Connector (-FC models): Mount the flexible conduit into the actuator's metal bushing by means of the provided screw with a torque of 1.2 Nm. Jacket the actuator's input wiring with suitable flexible conduit. Properly terminate the conduit in a suitable junction box.

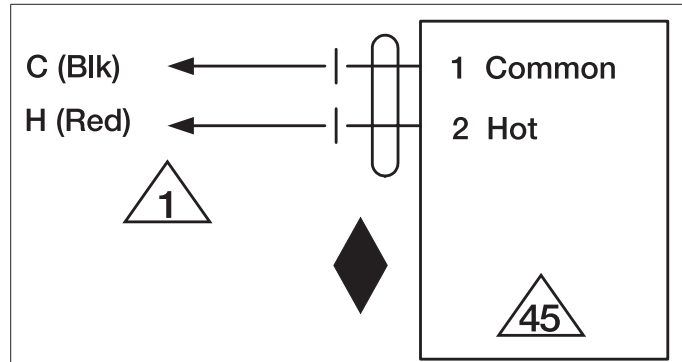
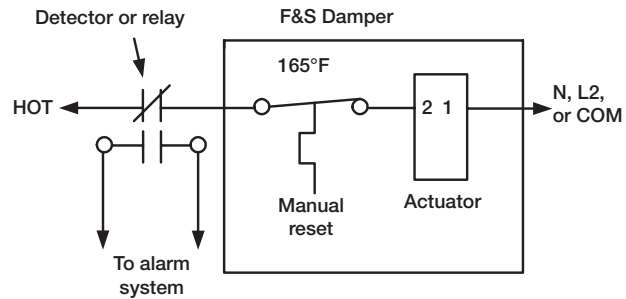
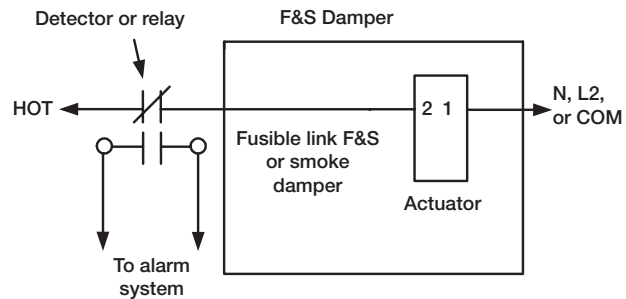
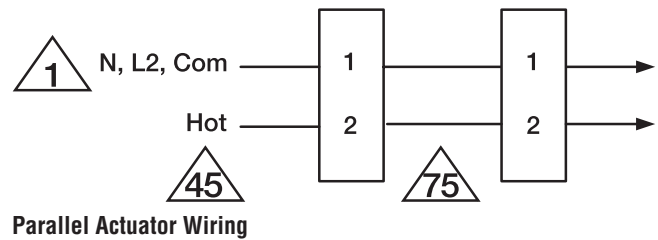
Accessories	
---BAE165 US	165° F electric thermal sensor, SPST, normally closed.
---S2A-F US	Auxiliary switch, 2x SPDT, 3A (0.5A inductive) @250 VAC max.

**Typical Specification**

All smoke and combination fire and smoke dampers shall be provided with Belimo FSTF, FSLF, FSNF, or FSAF actuators. All substitutions must be approved before submission of bid. Damper and actuator shall have UL 555S Listing for 250°F (350°F). Actuator shall have been tested to UL 2043 per requirements of IMC 602.2 and NEC 300.22 (c). Where position indication is required -S models with auxiliary switches or damper blade switches will be provided per code requirements.

**Wiring Diagrams**
**APPLICATION NOTES**

- Provide overload protection and disconnect as required.
- Actuators may be powered in parallel. Power consumption must be observed.
- Ground present on some models.


**24 VAC**

**Typical containment damper control wiring**

**Typical smoke or fusible link damper wiring**

**Parallel Actuator Wiring**

# FSNF120 US

On/Off, Spring Return, 350°F [177°C] for half hour, 120VAC, 15 Seconds Cycle Time



Technical Data	
Power Supply	120 VAC, ±10%, 50/60 Hz
Power consumption in operation	27 VA
Power consumption in rest position	6 W, 9 VA (50 Hz 15 VA), End stop 55 VA, 0.5 A slow blow fuse *
Shaft Diameter	1/2" to 1.05" round, centers on 1/2" and 3/4" with insert, 1.05" without insert
Electrical Connection	18 GA, 3 ft [1 m], 3 color coded wires
Overload Protection	electronic throughout 0° to 95° rotation
Electrical Protection	grounded enclosure, 120V
Angle of rotation	95°
Torque motor	70 in-lb [8 Nm] from 32...350°F [0...177°C]
direction of rotation motor	reversible with CW/CCW mounting
direction of rotation spring-return	reversible with cw/ccw mounting
Position indication	visual indicator, 0° to 95° (0° is full spring return position)
Running Time (Motor)	15 sec between 32...350°F [0...177°C], <15 sec at rated voltage & torque
Running Time (Fail-Safe)	15 sec
Ambient humidity	5...95% r.H. non-condensing
Ambient temperature	32...122°F [0...50°C]
Non-operating temperature	-40...176°F [-40...80°C]
Degree of Protection	IP40, NEMA 1
Housing material	zinc coated steel
Gears	steel, permanently lubricated
Agency Listing	cULus listed to UL873 and CAN/CSA C22.2 No.24, UL 2043 Listed for air plenum installation per NEC 300.22 and IMC Section 602 NYC Department of Buildings MEA 197-07-M.California State Fire Marshal Listing 3210-1593:101.
Noise level, motor	45 dB (A) motor, 62 dB (A) spring, inaudible holding
Maintenance	maintenance free
Quality Standard	ISO 9001
Weight	6.58 lb [3.0 kg]

† UL File XAPX.E108966

## Fire & Smoke damper actuator

### Application

The type FSNF spring-return actuator is intended for the operation of smoke and combination fire and smoke dampers in ventilation and air-conditioning systems. The actuator will meet requirements of UL555 and UL555S when tested as an assembly with the damper and will meet requirements of UBC for 15 second opening and closing at 350°F. Square footage of damper operated will depend on make and model and the temperature required.

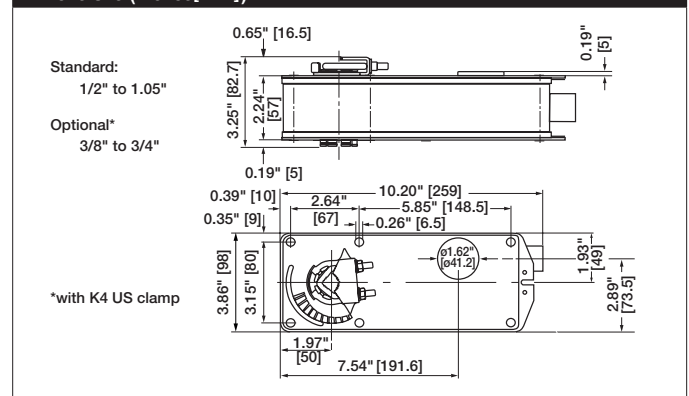
IMPORTANT 24VDC NOTE: The FSNF24 & -S models will not operate below 24VDC. A filtered and regulated power supply must be used.

### Operation

Mounting of the actuator to the damper axle shaft or jackshaft (3/8" to 1.05") is via a cold-weld clamp. Teeth in the clamp and V-bolt dig into the metal of both solid and hollow shafts maintaining a perfect connection. The specially designed clamp will not crush hollow shafts. The bottom end of the actuator is held by an anti-rotation strap or by a stud provided by the damper manufacturer.

The actuator is mounted in its fail safe position with the damper blade(s) closed. Upon applying power, the actuator drives the damper to the open position. The internal spring is tensioned at the same time. If the power supply is interrupted, the spring moves the damper back to its fail-safe position.

### Dimensions (Inches[mm])



### Safety Notes

\* Neither UL nor Belimo require local over-current protection. The FSNF actuators draw higher peak current when driving against any type of stop. If used, this requires the value of a local fuse or breaker to be increased to avoid nuisance opening or tripping. A 2.5 amp slow blow should be used for 24VAC. A 0.5 amp slow blow should be used for 120 VAC. A 0.25 amp slow blow should be used for 230V and a 0.3 amp slow blow for 208 VAC. Transformers: Note that while a 24V 100VA transformer would handle 2 actuators, a 4 A breaker or plug fuse is insufficient. A 5 amp slow blow would be required. Belimo Fire & Smoke actuators have passed the AMCA 520 and UL 555S Long Term Holding test. No special cycling is required during prolonged periods when actuator is driven open and held there. Periodic testing of dampers and actuators per local codes and NFPA 80 and NFPA 105 are required.

The actuator contains no components which the user can replace or repair. A 1/2" threaded connector is standard. FSNFxx-FC models have a 3/8" Flex Connector. Other than the connector, these actuators are identical to the conduit connector version.

⚠ WARNING: For Belimo Products sold in California, these Products do or may contain chemicals which are known to the State of California to cause cancer and or birth defects or other reproductive harms. For more information see [www.p65warnings.ca.gov](http://www.p65warnings.ca.gov).

**Accessories**

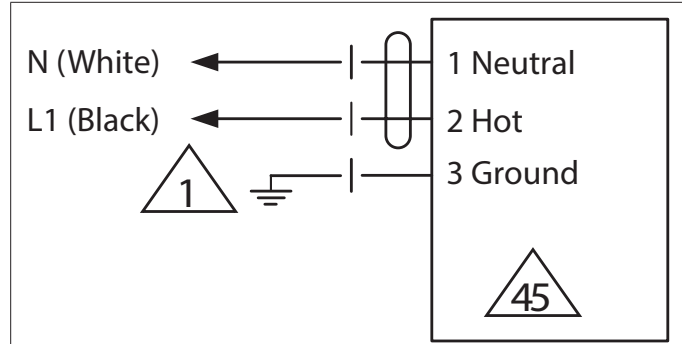
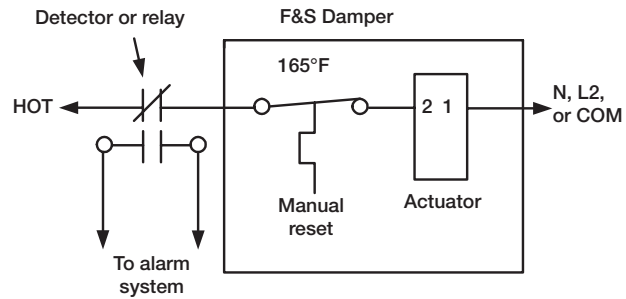
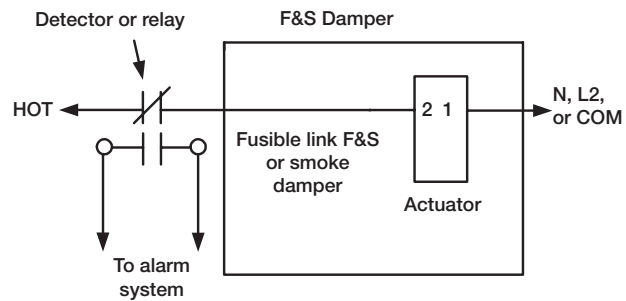
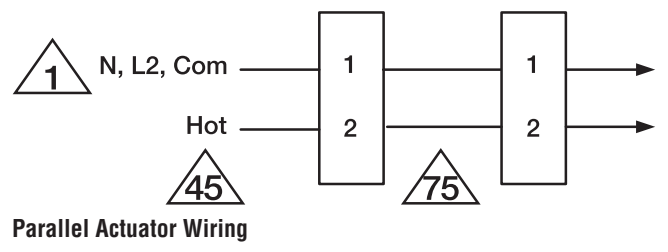
AF-P	Anti-rotation bracket AF/NF.
IND-AF2	End stop indicator
K4-1 US	Classic AF/NF jackshaft clamp (up to 1.05").
KH-AF-1 US	Classic AF/NF crankarm for Jackshaft to 1.05".
SH8	Push rod for KG6 & KG8 ball joints (36" L, 5/16" diameter).
ZDB-AF2 US	Angle of rotation limiter for Classic AF/NF.
ZG-100	Univ. right angle bracket 17"x11-1/8"x6" (HxWxbase).
ZG-101	Univ. right angle bracket 13x11x7-7/16" (HxWxbase).
ZG-AF US	Classic AF/NF crankarm adaptor kit.
ZG-AF108	Classic AF/NF crankarm adaptor kit with ZG-108.
ZG-DC1	Damper clip for damper blade, 3.5" width.
ZG-DC2	Damper clip for damper blade, 6" width.
ZS-100	Weather shield - galvaneal 13x8x6" (LxWxD).
ZS-150	Weather shield - PC w/ foam seal 16x8-3/8x4" (LxWxD).
ZS-260	Explosion proof housing.
ZS-300	NEMA 4X, 304 stainless steel enclosure.
BAE165 US	165° F electric thermal sensor, SPST, normally closed.
S2A-F US	Auxiliary switch, 2x SPDT, 3A (0.5A inductive) @250 VAC max.

**Typical Specification**

All smoke and combination fire and smoke dampers shall be provided with Belimo FSTF, FSLF, FSNF, or FSAF actuators. All substitutions must be approved before submission of bid. Damper and actuator shall have UL 555S Listing for 250°F (350°F). Actuator shall have been tested to UL 2043 per requirements of IMC 602.2 and NEC 300.22 (c). Where position indication is required -S models with auxiliary switches or damper blade switches will be provided per code requirements.

**Wiring Diagrams**
**INSTALLATION NOTES**

- Provide overload protection and disconnect as required.
- Actuators may be powered in parallel. Power consumption must be observed.
- Ground present on some models.


**120 VAC**

**Typical containment damper control wiring**

**Typical smoke or fusible link damper wiring**

**Parallel Actuator Wiring**



# FSNF230 US

On/Off, Spring Return, 350°F [177°C] for half hour, 230VAC, 15 Seconds Cycle Time



## Technical Data

Power Supply	230 VAC, ±10%, 50/60 Hz
Power consumption in operation	27 VA
Power consumption in rest position	5 W, 9 VA (60 Hz 6.5 VA), End stop 55 VA, 0.25 A slow blow fuse *
Shaft Diameter	1/2" to 1.05" round, centers on 1/2" and 3/4" with insert, 1.05" without insert
Electrical Connection	18 GA, 3 ft [1 m], 3 color coded wires
Overload Protection	electronic throughout 0° to 95° rotation
Electrical Protection	grounded enclosure, 230V
Angle of rotation	95°
Torque motor	70 in-lb [8 Nm] from 32...350°F [0...177°C]
direction of rotation motor	reversible with CW/CCW mounting
direction of rotation spring-return	reversible with cw/ccw mounting
Position indication	visual indicator, 0° to 95° (0° is full spring return position)
Running Time (Motor)	15 sec between 32...350°F [0...177°C], <15 sec at rated voltage & torque
Running Time (Fail-Safe)	15 sec
Ambient humidity	5...95% r.H. non-condensing
Ambient temperature	32...122°F [0...50°C]
Non-operating temperature	-40...176°F [-40...80°C]
Degree of Protection	IP40, NEMA 1
Housing material	zinc coated steel
Gears	steel, permanently lubricated
Agency Listing	cULus listed to UL873 and CAN/GSA C22.2 No.24, UL 2043 Listed for air plenum installation per NEC 300.22 and IMC Section 602 NYC Department of Buildings MEA 197-07-M.California State Fire Marshal Listing 3210-1593:101.
Noise level, motor	45 dB (A) motor, 62 dB (A) spring, inaudible holding
Maintenance	maintenance free
Quality Standard	ISO 9001
Weight	6.58 lb [3.0 kg]

† UL File XAPX.E108966

## Fire & Smoke damper actuator

### Application

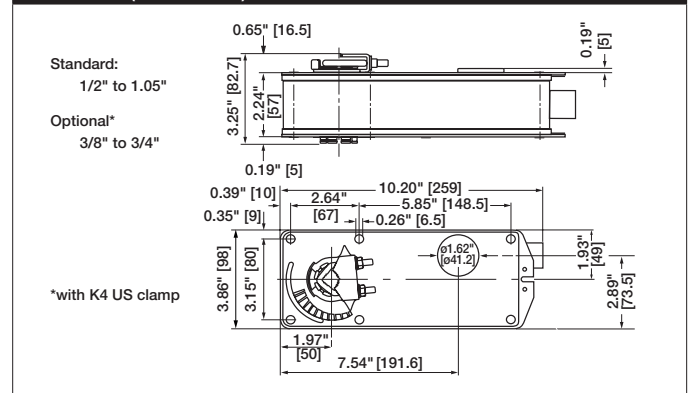
The type FSNF spring-return actuator is intended for the operation of smoke and combination fire and smoke dampers in ventilation and air-conditioning systems. The actuator will meet requirements of UL555 and UL555S when tested as an assembly with the damper and will meet requirements of UBC for 15 second opening and closing. Square footage of damper operated will depend on make and model and the temperature required.

### Operation

Mounting of the actuator to the damper shaft or jackshaft (3/8" to 1.05") is via a cold-weld clamp. Teeth in the clamp and V-bolt dig into the metal of both solid and hollow shafts maintaining a perfect connection. The specially designed clamp will not crush hollow shafts. The bottom end of the actuator is held by an anti-rotation strap or by a stud provided by the damper manufacturer.

The actuator is mounted in its fail safe position with the damper blade(s) closed. Upon applying power, the actuator drives the damper to the open position. The internal spring is tensioned at the same time. If the power supply is interrupted, the spring moves the damper back to its fail-safe position.

## Dimensions (Inches[mm])



## Safety Notes

\* Neither UL nor Belimo require local over-current protection. The FSNF actuators draw higher peak current when driving against any type of stop. If used, this requires the value of a local fuse or breaker to be increased to avoid nuisance opening or tripping. A 2.5 amp slow blow should be used for 24VAC. A 0.5 amp slow blow should be used for 120 VAC. A 0.25 amp slow blow should be used for 230V and a 0.3 amp slow blow for 208 VAC. Transformers: Note that while a 24V 100VA transformer would handle 2 actuators, a 4 A breaker or plug fuse is insufficient. A 5 amp slow blow would be required. Belimo Fire & Smoke actuators have passed the AMCA 520 and UL 555S Long Term Holding test. No special cycling is required during prolonged periods when actuator is driven open and held there. Periodic testing of dampers and actuators per local codes and NFPA 80 and NFPA 105 are required. The actuator contains no components which the user can replace or repair. A 1/2" threaded connector is standard. FSNFxx-FC models have a 3/8" Flex Connector. Other than the connector, these actuators are identical to the conduit connector version.

⚠ WARNING: For Belimo Products sold in California, these Products do or may contain chemicals which are known to the State of California to cause cancer and or birth defects or other reproductive harms. For more information see [www.p65warnings.ca.gov](http://www.p65warnings.ca.gov).

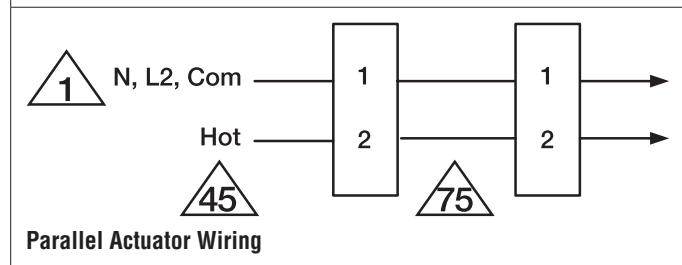
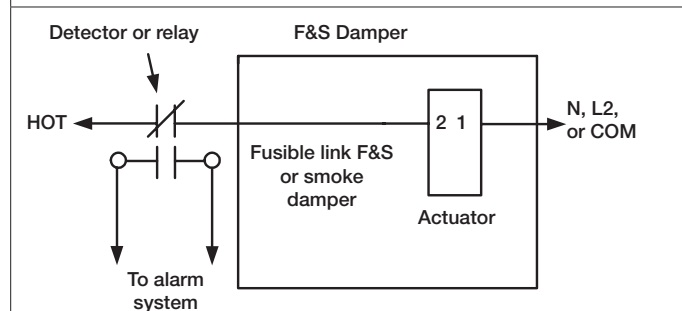
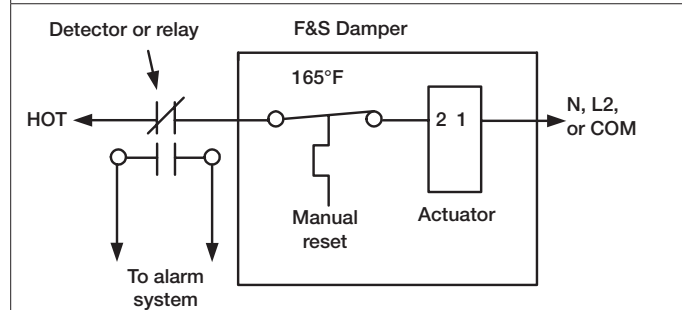
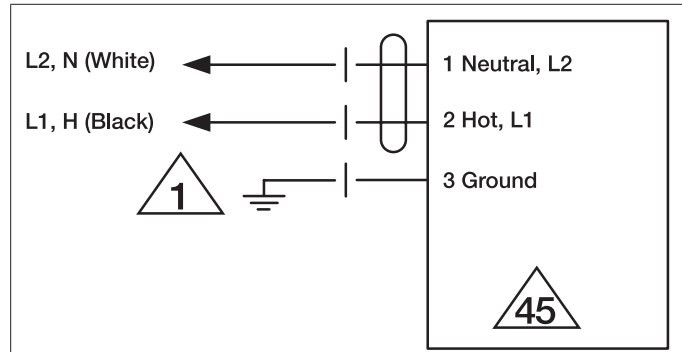
Accessories	
AF-P	Anti-rotation bracket AF/NF.
IND-AF2	End stop indicator
K4-1 US	Classic AF/NF jackshaft clamp (up to 1.05").
KH-AF-1 US	Classic AF/NF crankarm for Jackshaft to 1.05".
SH8	Push rod for KG6 & KG8 ball joints (36" L, 5/16" diameter).
ZDB-AF2 US	Angle of rotation limiter for Classic AF/NF.
ZG-100	Univ. right angle bracket 17"x11-1/8"x6" (HxWxbase).
ZG-101	Univ. right angle bracket 13x11x7-7/16" (HxWxbase).
ZG-AF US	Classic AF/NF crankarm adaptor kit.
ZG-AF108	Classic AF/NF crankarm adaptor kit with ZG-108.
ZG-DC1	Damper clip for damper blade, 3.5" width.
ZG-DC2	Damper clip for damper blade, 6" width.
ZS-100	Weather shield - galvaneal 13x8x6" (LxWxD).
ZS-150	Weather shield - PC w/ foam seal 16x8-3/8x4" (LxWxD).
ZS-260	Explosion proof housing.
ZS-300	NEMA 4X, 304 stainless steel enclosure.
BAE165 US	165° F electric thermal sensor, SPST, normally closed.
S2A-F US	Auxiliary switch, 2x SPDT, 3A (0.5A inductive) @250 VAC max.

**Typical Specification**

All smoke and combination fire and smoke dampers shall be provided with Belimo FSTF, FSLF, FSNF, or FSAF actuators. All substitutions must be approved before submission of bid. Damper and actuator shall have UL 555S Listing for 250°F (350°F). Actuator shall have been tested to UL 2043 per requirements of IMC 602.2 and NEC 300.22 (c). Where position indication is required -S models with auxiliary switches or damper blade switches will be provided per code requirements.

**Wiring Diagrams**
**INSTALLATION NOTES**

- Provide overload protection and disconnect as required.
- Actuators may be powered in parallel. Power consumption must be observed.
- Ground present on some models.





# FSNF24 US

On/Off, Spring Return, 350°F [177°C] for a half hour, 15 Seconds Cycle Time



Technical Data	
Power Supply	24 VAC, ±20%, 50/60 Hz, 24 VDC, 0% / +50%
Power consumption in operation	27 VA
Power consumption in rest position	3 W, 6.5 VA, End stop 55 VA, 2.5 A slow blow fuse *
Transformer sizing	40 VA (class 2 power source)
Shaft Diameter	1/2" to 1.05" round, centers on 1/2" and 3/4" with insert, 1.05" without insert
Electrical Connection	18 GA, 3 ft [1 m], 2 color coded wires
Overload Protection	electronic throughout 0° to 95° rotation
Electrical Protection	actuators are double insulated
Angle of rotation	95°
Torque motor	70 in-lb [8 Nm] from 32...350°F [0...177°C]
direction of rotation motor	reversible with CW/CCW mounting
direction of rotation spring-return	reversible with cw/ccw mounting
Position indication	visual indicator, 0° to 95° (0° is full spring return position)
Running Time (Motor)	15 sec between 32...350°F [0...177°C], <15 sec at rated voltage & torque
Running Time (Fail-Safe)	15 sec
Ambient humidity	5...95% r.H. non-condensing
Ambient temperature	32...122°F [0...50°C]
Non-operating temperature	-40...176°F [-40...80°C]
Degree of Protection	IP40, NEMA 1
Housing material	zinc coated steel
Gears	steel, permanently lubricated
Agency Listing	cULus listed to UL873 and CAN/CSA C22.2 No.24, UL 2043 Listed for air plenum installation per NEC 300.22 and IMC Section 602 NYC Department of Buildings MEA 197-07-M.California State Fire Marshal Listing 3210-1593:101.
Noise level, motor	45 dB (A) motor, 62 dB (A) spring, inaudible holding
Maintenance	maintenance free
Quality Standard	ISO 9001
Weight	5.71 lb [2.8 kg]

† UL File XAPX.E108966

## Fire & Smoke damper actuator

### Application

The type FSNF spring-return actuator is intended for the operation of smoke and combination fire and smoke dampers in ventilation and air-conditioning systems. The actuator will meet requirements of UL555 and UL555S when tested as an assembly with the damper and will meet requirements of UBC for 15 second opening and closing at 350°F. Square footage of damper operated will depend on make and model and the temperature required.

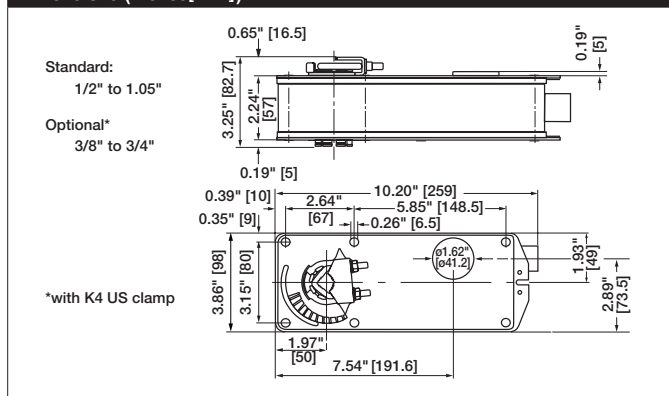
IMPORTANT 24VDC NOTE: The FSNF24 & -S models will not operate below 24VDC. A filtered and regulated power supply must be used.

### Operation

Mounting of the actuator to the damper axle shaft or jackshaft (3/8" to 1.05") is via a cold-weld clamp. Teeth in the clamp and V-bolt dig into the metal of both solid and hollow shafts maintaining a perfect connection. The specially designed clamp will not crush hollow shafts. The bottom end of the actuator is held by an anti-rotation strap or by a stud provided by the damper manufacturer.

The actuator is mounted in its fail safe position with the damper blade(s) closed. Upon applying power, the actuator drives the damper to the open position. The internal spring is tensioned at the same time. If the power supply is interrupted, the spring moves the damper back to its fail-safe position.

### Dimensions (Inches[mm])



### Safety Notes

\* Neither UL nor Belimo require local over-current protection. The FSNF actuators draw higher peak current when driving against any type of stop. If used, this requires the value of a local fuse or breaker to be increased to avoid nuisance opening or tripping. A 2.5 amp slow blow should be used for 24VAC. A 0.5 amp slow blow should be used for 120 VAC. A 0.25 amp slow blow should be used for 230V and a 0.3 amp slow blow for 208 VAC. Transformers: Note that while a 24V 100VA transformer would handle 2 actuators, a 4 A breaker or plug fuse is insufficient. A 5 amp slow blow would be required. Belimo Fire & Smoke actuators have passed the AMCA 520 and UL 555S Long Term Holding test. No special cycling is required during prolonged periods when actuator is driven open and held there. Periodic testing of dampers and actuators per local codes and NFPA 80 and NFPA 105 are required.

The actuator contains no components which the user can replace or repair. A 1/2" threaded connector is standard. FSNFxx-FC models have a 3/8" Flex Connector. Other than the connector, these actuators are identical to the conduit connector version.

⚠ WARNING: For Belimo Products sold in California, these Products do or may contain chemicals which are known to the State of California to cause cancer and or birth defects or other reproductive harms. For more information see [www.p65warnings.ca.gov](http://www.p65warnings.ca.gov).

**Accessories**

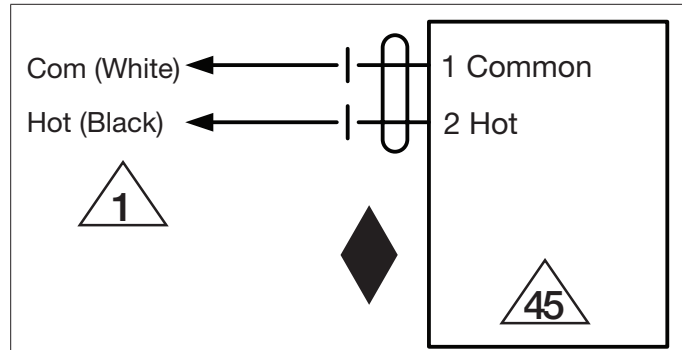
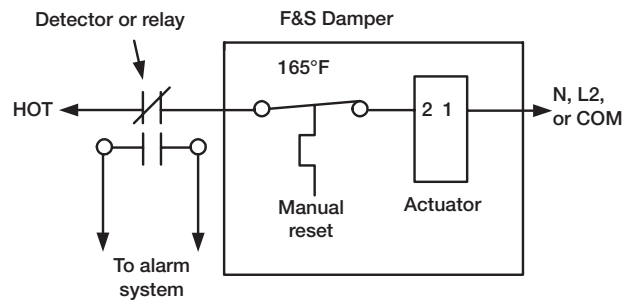
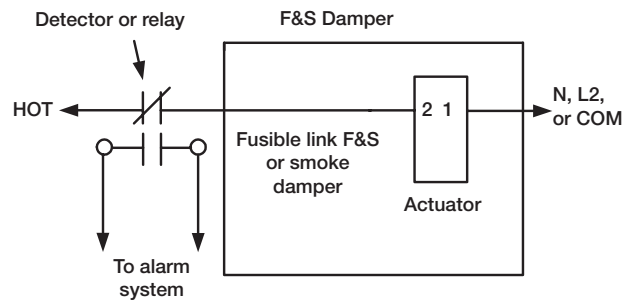
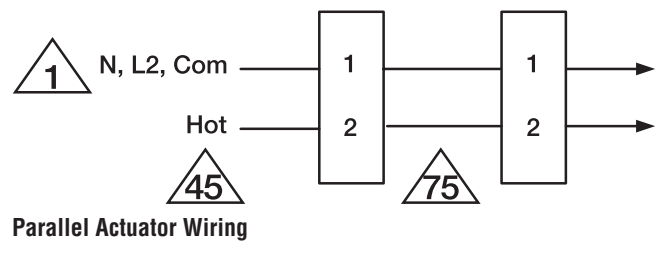
AF-P	Anti-rotation bracket AF/NF.
IND-AF2	End stop indicator
K4-1 US	Classic AF/NF jackshaft clamp (up to 1.05").
KH-AF-1 US	Classic AF/NF crankarm for Jackshaft to 1.05".
SH8	Push rod for KG6 & KG8 ball joints (36" L, 5/16" diameter).
ZDB-AF2 US	Angle of rotation limiter for Classic AF/NF.
ZG-100	Univ. right angle bracket 17"x11-1/8"x6" (HxWxbase).
ZG-101	Univ. right angle bracket 13x11x7-7/16" (HxWxbase).
ZG-AF US	Classic AF/NF crankarm adaptor kit.
ZG-AF108	Classic AF/NF crankarm adaptor kit with ZG-108.
ZG-DC1	Damper clip for damper blade, 3.5" width.
ZG-DC2	Damper clip for damper blade, 6" width.
ZS-100	Weather shield - galvaneal 13x8x6" (LxWxD).
ZS-150	Weather shield - PC w/ foam seal 16x8-3/8x4" (LxWxD).
ZS-260	Explosion proof housing.
ZS-300	NEMA 4X, 304 stainless steel enclosure.
BAE165 US	165° F electric thermal sensor, SPST, normally closed.
S2A-F US	Auxiliary switch, 2x SPDT, 3A (0.5A inductive) @250 VAC max.

**Typical Specification**

All smoke and combination fire and smoke dampers shall be provided with Belimo FSTF, FSLF, FSNF, or FSAF actuators. All substitutions must be approved before submission of bid. Damper and actuator shall have UL 555S Listing for 250°F (350°F). Actuator shall have been tested to UL 2043 per requirements of IMC 602.2 and NEC 300.22 (c). Where position indication is required -S models with auxiliary switches or damper blade switches will be provided per code requirements.

**Wiring Diagrams**
**INSTALLATION NOTES**

- Provide overload protection and disconnect as required.
- Actuators may be powered in parallel. Power consumption must be observed.
- Ground present on some models.
- Meets cULus requirements without the need of an electrical ground connection.


**24 VAC/DC**

**Typical containment damper control wiring**

**Typical smoke or fusible link damper wiring**

**Parallel Actuator Wiring**



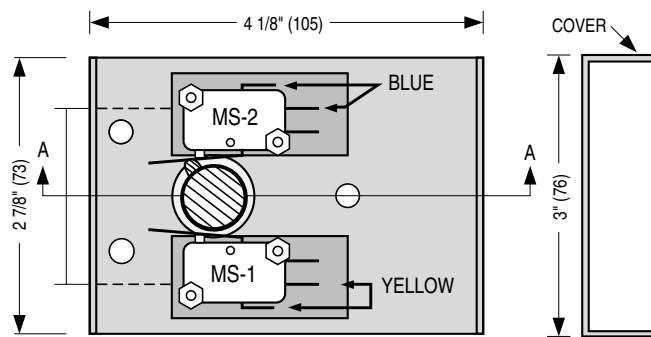
## POSITION INDICATOR PACKAGE

FOR COMBINATION FIRE / SMOKE, SMOKE AND CONTROL DAMPERS

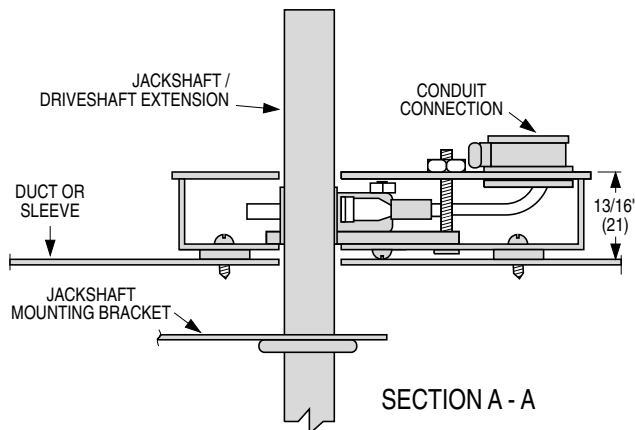
MODEL: MLS-300. For use with GGD221/121 (electric) and 331-2961 / 3060 (pneumatic) actuators

### APPLICATION:

- The MLS-300 Position Indicator Package operates as a function of the damper blade position and provides the ability to remotely indicate damper blade position.
- The MLS-300 incorporates two SPDT switches and provides a positive open or closed signal when used in conjunction with remote indicator lights. MLS-300's are used in active smoke control management systems to positively indicate the status of all combination fire/smoke and smoke dampers in the building.
- The MLS-300 is available only as a factory installed option on combination fire/smoke and smoke dampers.
- The MLS-300 may also be used to provide a stop/start circuit for remote fans or to signal alarms.



EXTERNAL RIGHT HAND MOUNTING: FRONT VIEW (LESS COVER)



### Position Indicator Microswitch Data:

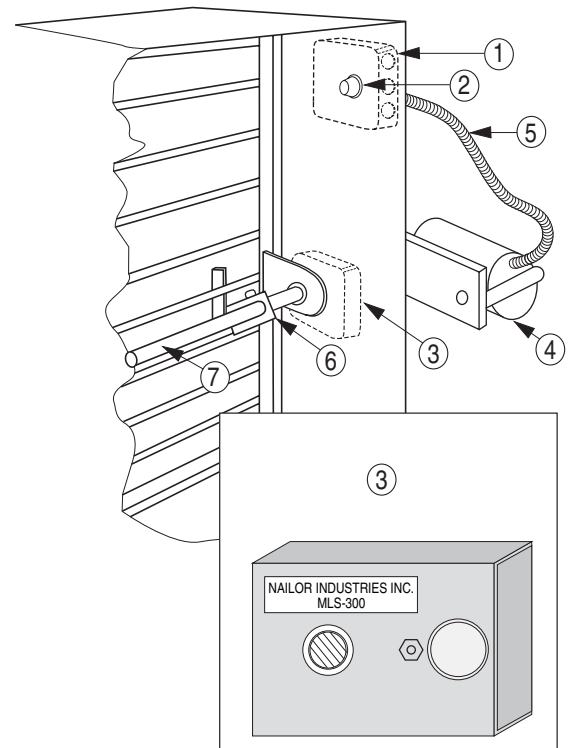
Switch Type: Single Pole double throw (2)  
 15 Amps, 1/3 HP, 125, 250 Vac or 24 Vdc.  
 1/2 Amp, 125 Vdc. 1/4 Amp, 250 Vdc.

### Standard Mounting:

**MS1** is damper open signal.  
**MS2** is damper closed signal.

### Non-Standard Mounting:

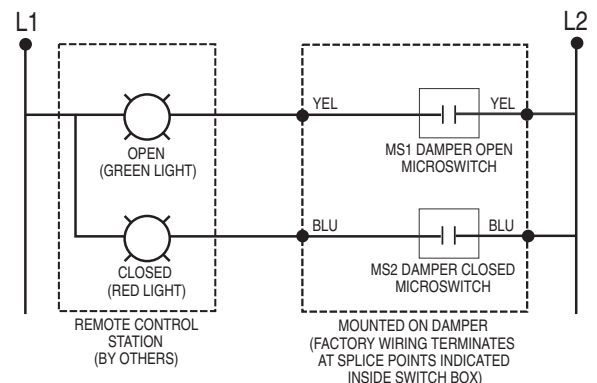
**Important:** Installer must double check continuity of MS1 and MS2 before wiring to determine which switch signals the damper's open or closed position.



### Typical Combination Fire / Smoke Damper Installation With UL Listed Actuator

#### Description:

1. Electrical Junction Box (and EP switch with pneumatic actuator[s])
2. ERL 165, 212, 250, 350°F Electric Resettable Link (Heat Sensor)
3. Position indicator package
4. Actuator (pneumatic illustrated).
5. Silicone Tubing or Flexible Conduit
6. Over-Center Knee Lock
7. Jackshaft



Dimensions are in inches (mm).

<b>SCHEDULE TYPE:</b>				
<b>PROJECT:</b>				
<b>ENGINEER:</b>	<b>DATE</b>	<b>B SERIES</b>	<b>SUPERSEDES</b>	<b>DRAWING NO.</b>
<b>CONTRACTOR:</b>	7 - 20 - 07	FD - ACC	12 - 4 - 02	MLS-300-2



**POSITION INDICATOR PACKAGE**

FOR COMBINATION FIRE/SMOKE AND SMOKE DAMPERS  
FOR USE WITH BELIMO AND HONEYWELL ACTUATORS

**MODEL: MLS-300**

**APPLICATION:**

When ordered with the MLS-300 Position Indicator Switch Pack, Nailor combination fire/smoke and smoke dampers that utilize factory installed Belimo or Honeywell fire/smoke actuators will be supplied as standard with an actuator that has an integral internal mounted switch pack. The auxiliary switches provide an on/off signal at two points in the actuator stroke and this signal can be routed to a Fire Fighter's Smoke Control Station for remote open/closed damper position status in Smoke Control Management Applications. Alternatively, they may be field wired to a local accessible damper control panel (Nailor DCP16). Both provide a means to cycle test the damper as part of a scheduled building maintenance program.

**ELECTRICAL SWITCH RATINGS:**

**Honeywell:**

**Models MS4104F1210, MS4109F1210, MS4604F1210, MS4609F1210:**

Ratings (maximum load): 120 VAC/24 VDC, 3A resistive  
Settings (fixed): 7° nominal stroke, 85° nominal stroke

**Model MS8104F1210, MS8109F1210:**

Ratings (maximum load): 24 VAC/DC, 3A resistive  
Settings (fixed): 7° nominal stroke, 85° nominal stroke

**Model MS4120F1204, MS4620F1203, MS8120F1200:**

Ratings (maximum load): 250 VAC, 5A resistive  
Settings (fixed): 7° nominal stroke, 85° nominal stroke

**Belimo:**

**Model FSTF120-S, FSTF24-S, FSTF230-S:**

2 x SPST 3A resistive, 0.5A inductive @ 120 VAC,  
Settings (fixed): One switch at 10°, one switch at 80°

**Models FSLF24-S, FSLF120-S, FSLF230-S:**

2 x SPST 3A resistive, 0.5A inductive @ 120/250 VAC,  
1mA @ 5 VDC,  
Settings (fixed): One switch at 10°, one switch at 85°

**Models FSNF24-S, FSNF120-S, FSNF230-S:**

2 x SPDT 7A resistive, 2.5A inductive @ 120/250 VAC,  
Settings (fixed): One switch at 10°, one at 85°

**Model FSAFA24-S, FSAFA120-S, FSAF230A-S:**

2 x SPST 6A resistive, 2.5A inductive @ 120/250 VAC,  
Settings (fixed): One switch fixed at 10°, one at 85°

**Model FSAFB24-SR-S:**

2 x SPST 3A resistive, 0.5A inductive @ 120/250 VAC,  
Settings: One switch set at + 10°, one adjustable from 10° to 90°



**Fig. 1 - Typical Honeywell Fire/Smoke Actuator with auxiliary switches (MLS-300)**



**Fig. 2 - Typical Belimo Fire/Smoke Actuator with auxiliary switches (MLS-300)**

Refer to manufacturer's submittal and installation and operating manual for complete details and wiring diagrams.

<b>SCHEDULE TYPE:</b>				
<b>PROJECT:</b>				
<b>ENGINEER:</b>	<b>DATE</b>	<b>B SERIES</b>	<b>SUPERSEDES</b>	<b>DRAWING NO.</b>
<b>CONTRACTOR:</b>	12 - 29 - 17	FD - ACC	4 - 28 - 14	MLS-300-3

### Application and Operation

The Nailor PRL Pneumatic Replaceable Link is a UL Classified heat responsive device used in conjunction with Nailor combination fire/smoke dampers.

The PRL is supplied as standard on all combination fire/smoke dampers ordered with a pneumatic actuator. An alternative to the PRL would be the Nailor ERL (Electric Resettable Link) with an EP (Electric/Pneumatic) Switch.

The PRL is a factory mounted pneumatic release valve/replaceable fusible link assembly. The PRL's function is to sense an abnormally high temperature, as caused by a fire, and allow the damper to close in order to prevent the spread of fire and smoke.

**Fire Control Mode:** The PRL activates when fire temperatures in excess of 165, 212 or 280°F (74, 100 or 138°C) are detected. When the fusible link melts, air from the pneumatic actuator(s) is exhausted and the actuator spring return mechanism causes the damper to close and lock.

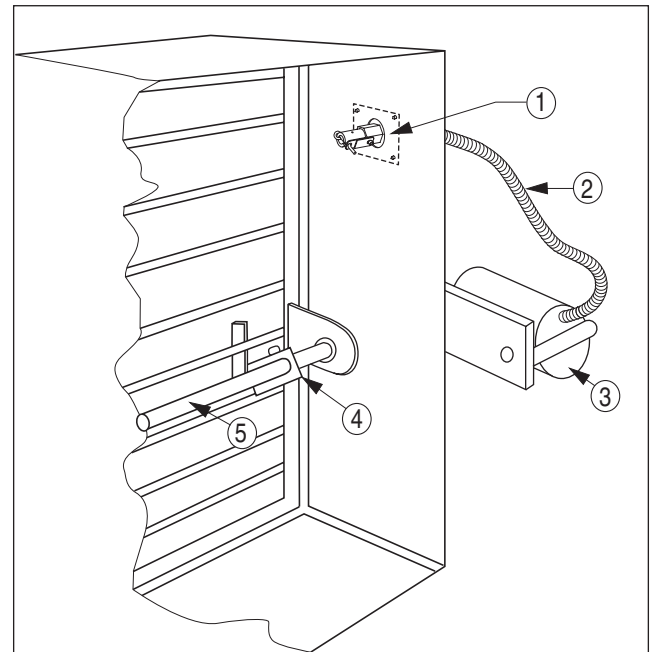
**Smoke Control Mode:** When a signal is detected via a normally closed smoke detector connection, during system testing or if power failure occurs, the damper will close and remain closed. When the smoke signal ceases (smoke detector reset), the test is completed or power is restored, the damper will automatically reset to the open position.

An EP (Electric/Pneumatic) Switch, by others, must be present in the system.

All pneumatic actuators are factory mounted with a fail close (Normally Closed) damper connection.

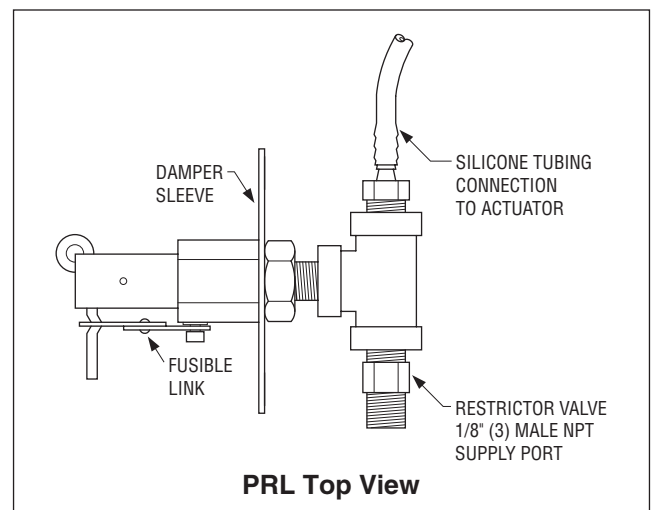
#### Notes:

1. The PRL must be installed at the factory and cannot be added in the field, in accordance with UL requirements.
2. A single PRL may be used to control up to a maximum of four pneumatic actuators.
3. Pneumatic actuators are to be field piped per local codes.



#### Typical Combination Fire/Smoke Damper Detail with UL Listed Pneumatic Actuator Description:

1. PRL 165, 212 or 280°F Pneumatic Replaceable Link
2. Silicone Tubing
3. Pneumatic Actuator
4. Over-center Knee Lock
5. Jackshaft



<b>SCHEDULE TYPE</b>				
<b>PROJECT</b>				
<b>ENGINEER</b>				
<b>CONTRACTOR</b>				
Dimensions are in inches (mm).				
<b>DATE</b>	<b>B SERIES</b>	<b>SUPERSEDES</b>	<b>DRAWING NO.</b>	
9 - 9 - 08	FD-ACC	4 - 15 - 03	PRL	