

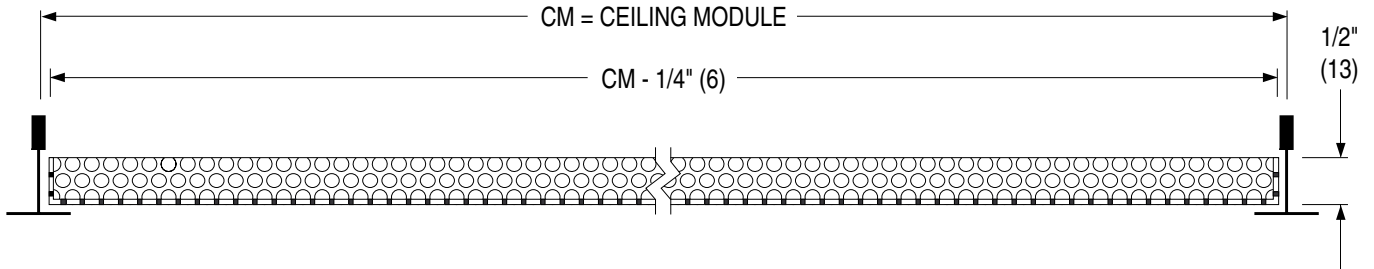

**PERFORATED CEILING DIFFUSERS
RETURN PANEL
MODELS: 4302, 4302A**

TYPE L Lay-in



Available Ceiling Module Sizes

Ceiling Module CM	
Imperial Modules (inches)	Metric Modules (mm)
12 x 12	300 x 300
16 x 16	400 x 400
20 x 20	500 x 500
24 x 12	600 x 300
24 x 24	600 x 600
48 x 24	1200 x 600

DESCRIPTION:

1. Material: Corrosion-resistant steel.
2. Model 4302 perforated return is designed for non-ducted return or exhaust air applications.
3. Panels match Models 4320, 4320CB, 4320F and 4320M in appearance after installation.
4. Installs in Lay-in T-Bar ceiling systems.
5. Perforated face has 3/16" diameter holes on 1/4" staggered centres.
6. Standard finish is AW Appliance White.

OPTIONS:

- Aluminum construction. (Model 4302A).
Finish: _____
- SP Special _____.

SCHEDULE TYPE:					
PROJECT:					
ENGINEER:		DATE	B SERIES	SUPERSEDES	DRAWING NO.
CONTRACTOR:		29 - 3 - 00R	4300	30 - 4 - 99	4302



PERFORATED CEILING DIFFUSER
RETURN PANEL • DROP FACE
MODEL: 4302-DF

TYPE L Lay-in T-Bar

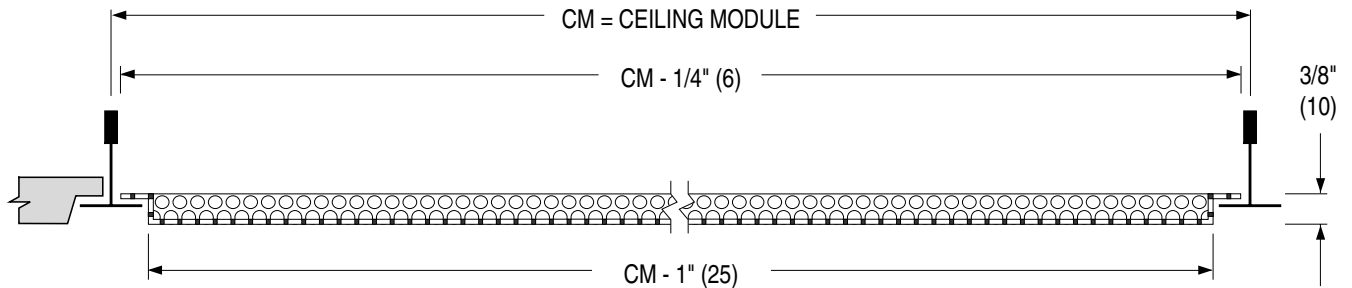

Available Ceiling Module Sizes

Ceiling Module CM	
Imperial Modules (inches)	Metric Modules (mm)
12 x 12	300 x 300
16 x 16	400 x 400
20 x 20	500 x 500
24 x 12	600 x 300
24 x 24	600 x 600
48 x 24	1200 x 600

DESCRIPTION:

1. Material: Corrosion-resistant steel.
2. Model 4302-DF perforated return is designed for non-ducted return or exhaust air applications.
3. Panels match Models 4325, 4325CB, 4325F and 4325M in appearance after installation.
4. Installs in Lay-in T-Bar ceiling systems.
Face lies flush with ceiling tiles in a Tegular ceiling.
5. Perforated face has 3/16" diameter holes on 1/4" staggered centres.
6. Standard finish is AW Appliance White.

OPTIONS:

Finish:
 SP Special _____.

SCHEDULE TYPE:					
PROJECT:					
ENGINEER:		DATE	B SERIES	SUPERSEDES	DRAWING NO.
CONTRACTOR:		21 - 3 - 00R	4300	NEW	4302-DF



PERFORATED CEILING DIFFUSER
RETURN PANEL • NARROW REGRESSED T-BAR
MODELS: 4302-F

For Fineline® Type Ceiling Systems

TYPE L Lay-in

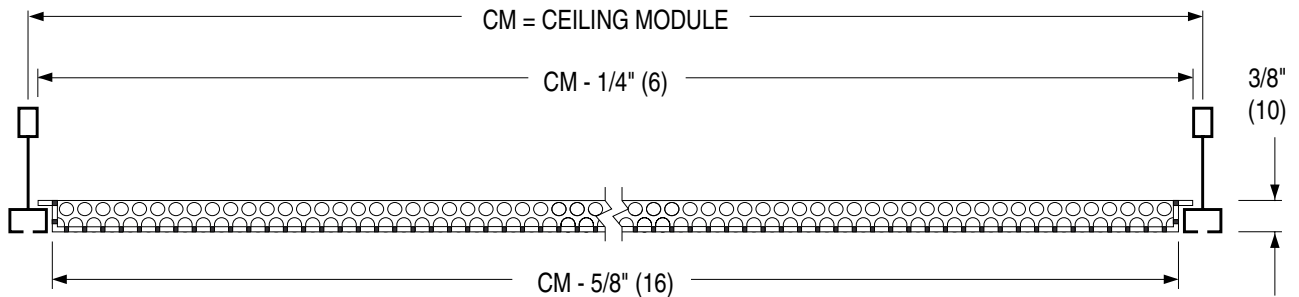

Available Ceiling Module Sizes

Ceiling Module CM	
Imperial Modules (inches)	Metric Modules (mm)
20 x 20	500 x 500
24 x 24	600 x 600

DESCRIPTION:

1. Material: Corrosion-resistant steel.
2. Model 4302-F perforated return is designed for nonducted return or exhaust air applications.
3. Panels match Models 4320, 4320CB, 4320F and 4320M in appearance after installation.
4. Installs in narrow, regressed T-bar ceiling systems.
5. Perforated face has 3/16" diameter holes on 1/4" staggered centres.
6. Standard finish is AW Appliance White.

OPTIONS:

Finish:

SP Special _____.

Fineline® is a registered trademark of USG Interiors Inc.

SCHEDULE TYPE:					
PROJECT:					
ENGINEER:		DATE	B SERIES	SUPERSEDES	DRAWING NO.
CONTRACTOR:		21 - 3 - 00R	4300	NEW	4302-F



PERFORATED CEILING DIFFUSER
 FLUSH FACE • ROUND NECK • ALL ALUMINUM
 CONSTRUCTION • MRI SUITABLE
MODELS: 4310A SUPPLY • 4310AR RETURN

TYPE L Lay-in T-Bar

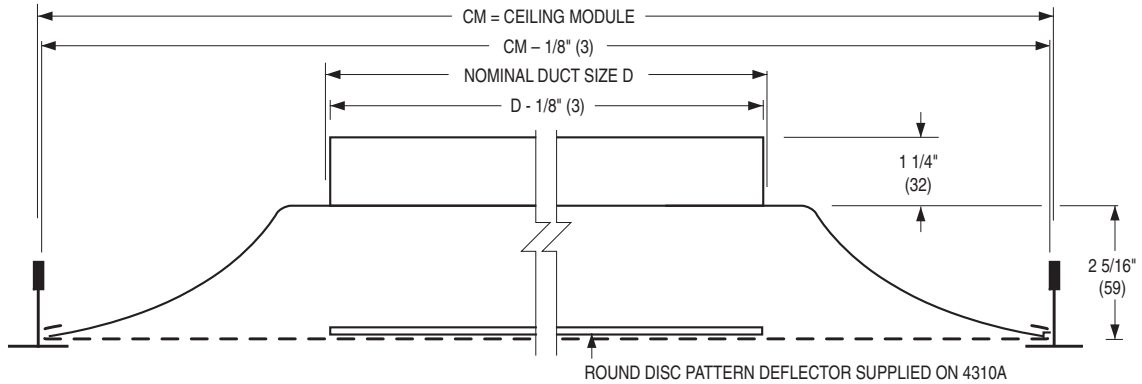

Available Combinations of Ceiling Module vs. Neck Size

Ceiling Module CM		Nominal Duct Size D	
Imperial Modules	Metric Modules	Round Neck	
		Imperial Units (in.)	Metric Units (mm)
24 x 24	600 x 600	6, 8,	152, 203,
		10, 12,	254, 305,
		14, 15,	356, 381

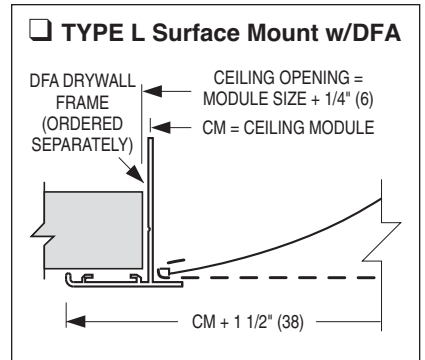

DESCRIPTION:

1. Material: All aluminum construction. Suitable for MRI rooms.
2. Diffuser features a smoothly contoured die-formed back pan and wrap-around fixed perforated face. The round disc pattern deflector provides a true 360° radial horizontal air pattern. A tight air pattern protects the ceiling against smudging, providing excellent performance in VAV systems.
3. Perforated face has 3/16" (5) diameter holes on 1/4" (6) staggered centers.
4. Return model 4310AR is the same construction, but omits pattern deflector. It is suitable for ducted return applications.
5. Standard finish is AW (Appliance White) face and border.

OPTIONS:

- Finish:
- BA Black back pan and deflectors with Appliance White face.
 - SP Special _____.

SCHEDULE TYPE:
PROJECT:
ENGINEER:
CONTRACTOR:

Dimensions are in inches (mm).

DATE	B SERIES	SUPERSEDES	DRAWING NO.
2 - 6 - 17	4300	11 - 5 - 07	4310A



PERFORATED CEILING DIFFUSER
 RETURN • PREMIUM ARCHITECTURAL QUALITY
 SQUARE NECK (FULL SIZE)
MODELS: 4330R, 4330RA

TYPE L Lay-in T-Bar

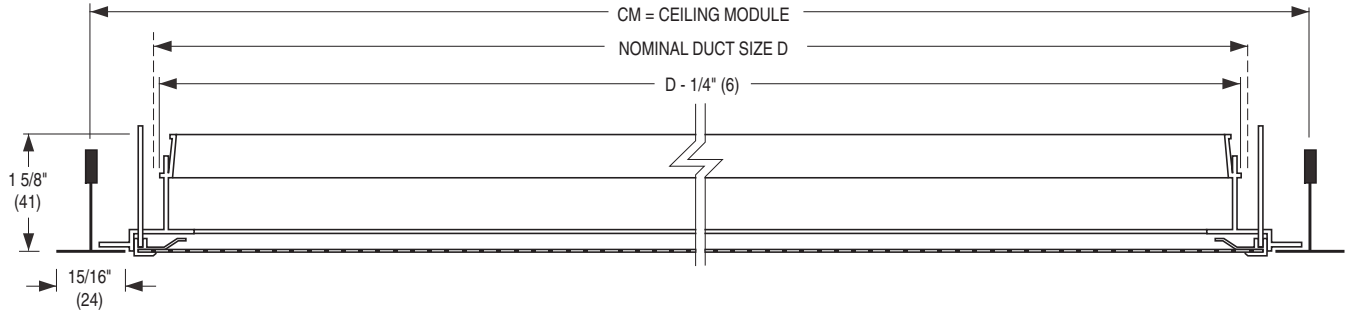

Imperial Module & Metric Module Table

Ceiling Module CM		Nominal Duct Size D	
Imperial Modules	Metric Modules	Square Neck	
		Imperial Modules (inches)	Metric Modules (mm)
12 x 12	300 x 300	10 x 10	250 x 250
16 x 16	400 x 400	14 x 14	350 x 350
24 x 12	600 x 300	22 x 10	550 x 250
20 x 20	500 x 500	18 x 18	450 x 450
24 x 24	600 x 600	22 x 22	550 x 550
48 x 24	1200 x 600	46 x 22	1150 x 550

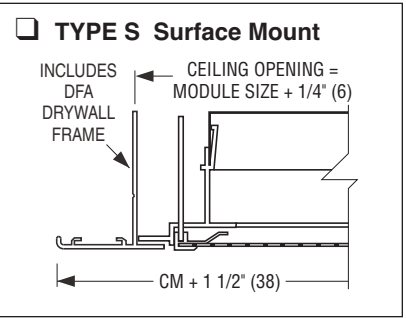

DESCRIPTION:

1. Material: Extruded aluminum border frame. Corrosion-resistant steel perforated face.
2. Designed to match supply air Model 4330 in appearance, except that the air pattern controllers are omitted. The diffuser features a mitered corner aluminum frame that encapsulates the perforated face providing a narrow, visible border within the T-bar module. This version is for ducted or ductless return air applications. Features a dedicated frame assembly which has a neck that is 2" (51) less than the ceiling module size for maximum free area.
3. Removable face has quick release spring latches for easy access to optional damper.
4. Perforated face has 3/16" (5) diameter holes on 1/4" (6) staggered centers.
5. Standard finish is AW Appliance White.

OPTIONS:

- Aluminum perforated face. (Model 4330RA).
Finish: _____
- SP Special _____

SCHEDULE TYPE:	
PROJECT:	
ENGINEER:	
CONTRACTOR:	

Dimensions are in inches (mm).

DATE	B SERIES	SUPERSEDES	DRAWING NO.
2 - 6 - 17	4300	3 - 10 - 16	4330R-1



PERFORATED CEILING DIFFUSER
 RETURN • PREMIUM ARCHITECTURAL QUALITY
 ROUND OR SQUARE NECK
MODELS: 4330R, 4330RA

TYPE L Lay-in T-Bar

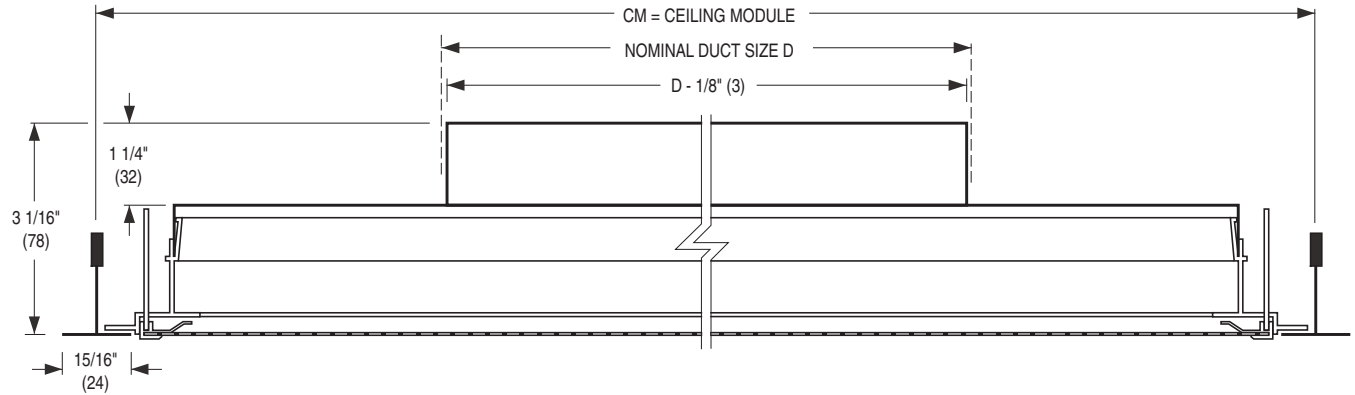

Available Combinations of Ceiling Module vs. Neck Size

Ceiling Module CM		Nominal Duct Size D			
Imperial Modules	Metric Modules	Round Neck		Square Neck	
		Imperial Units (inches)	Metric Units (mm)	Imperial Units (inches)	Metric Units (mm)
12 x 12	300 x 300	5, 6, 7, 8	127, 152, 178, 203	6 x 6, 8 x 8	152 x 152, 203 x 203
16 x 16	400 x 400	5, 6, 7, 8, 10, 12	127, 152, 178, 203, 254, 305	6 x 6, 8 x 8, 10 x 10, 12 x 12	152 x 152, 203 x 203, 254 x 254, 305 x 305
24 x 12	600 x 300	5, 6, 7, 8	127, 152, 178, 203	6 x 6, 8 x 8, 18 x 6	152 x 152, 203 x 203, 457 x 152
20 x 20	500 x 500	5, 6, 7, 8, 10, 12, 14	127, 152, 178, 203, 254, 305, 356	6 x 6, 8 x 8, 10 x 10, 12 x 12, 14 x 14, 15 x 15, 16 x 16	152 x 152, 203 x 203, 254 x 254, 305 x 305, 356 x 356, 381 x 381, 406 x 406
24 x 24	600 x 600	5, 6, 7, 8, 10, 12, 14, 15, 16	127, 152, 178, 203, 254, 305, 356, 381, 406	6 x 6, 8 x 8, 10 x 10, 12 x 12, 14 x 14, 15 x 15, 16 x 16, 18 x 18, 20 x 20, 22 x 22	152 x 152, 203 x 203, 254 x 254, 305 x 305, 356 x 356, 381 x 381, 406 x 406, 457 x 457, 508 x 508, 559 x 559

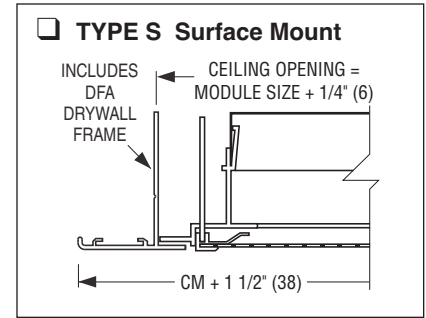

DESCRIPTION:

1. Material: Extruded aluminum border frame. Corrosion-resistant steel perforated face and back pan.
2. Designed to match supply air Model 4330 in appearance, except that the air pattern controllers are omitted. The diffuser features a mitered corner aluminum frame that encapsulates the perforated face providing a narrow, visible border within the T-bar module. This version is for ducted return applications; for connection to flexible or rigid round or square duct.
3. Removable face has quick release spring latches for easy access to optional damper.
4. Perforated face has 3/16" (5) diameter holes on 1/4" (6) staggered centers.
5. Standard finish is AW Appliance White.

OPTIONS:

- Aluminum perforated face/steel backpan. (Model 4330RA).
Finish:
- BA Black back pan with Appliance White face.
- SP Special _____.

SCHEDULE TYPE:		Dimensions are in inches (mm).			
PROJECT:					
ENGINEER:	DATE	B SERIES	SUPERSEDES	DRAWING NO.	
CONTRACTOR:	2 - 6 - 17	4300	3 - 10 - 16	4330R-2	



PERFORATED CEILING DIFFUSER
 RETURN • REMOVABLE FACE
 SURFACE MOUNT • SQUARE NECK
MODELS: 4340R AND 4340RA

TYPE S Surface Mount

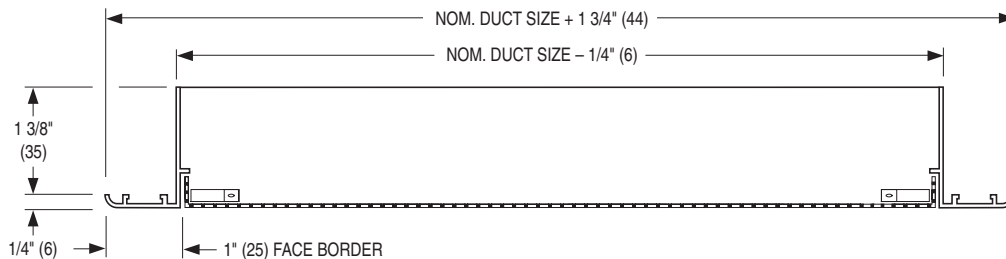
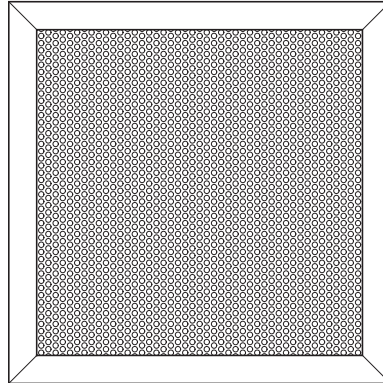

DESCRIPTION:

1. Material: Corrosion-resistant steel perforated face. Extruded aluminum frame.
2. Designed to match supply air models 4340CB and 4340M in appearance, except that the air pattern controllers are omitted. Suitable for ducted or ductless return air applications. Diffuser frame is mechanically interlocked for strength with hairline mitered corners.
3. Minimum size 6" x 6" (152 x 152). Maximum size 24" x 24" (610 x 610).
4. Removable face has concealed latches for easy access to optional damper and cleaning.
5. Perforated face has 3/16" (5) diameter holes on 1/4" (6) staggered centers (51% free area).
6. Type N standard fastening is with sheet metal screws (by others), through the neck of the diffuser outer frame.
7. Standard finish is AW Appliance White.

OPTIONS:

- Aluminum perforated face (Model 4340RA).
- Finish:**
- SP Special _____.
- Fastening:**
- Type A Countersunk screwholes on face of outer frame.

SCHEDULE TYPE:		Dimensions are in inches (mm).			
PROJECT:					
ENGINEER:	DATE	B SERIES	SUPERSEDES	DRAWING NO.	
CONTRACTOR:	6 - 30 - 03	4300	3 - 24 - 03	4340R	



PERFORATED CEILING DIFFUSERS
FIBERGLASS PLENUM
RETURN • 24" x 24" MODULE FOR T-BAR CEILINGS
MODEL: 4350R

TYPE L Lay-in T-Bar

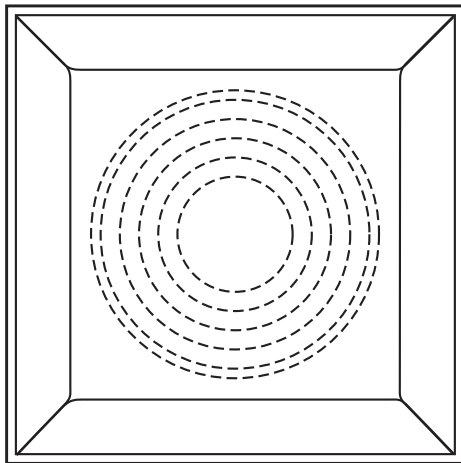
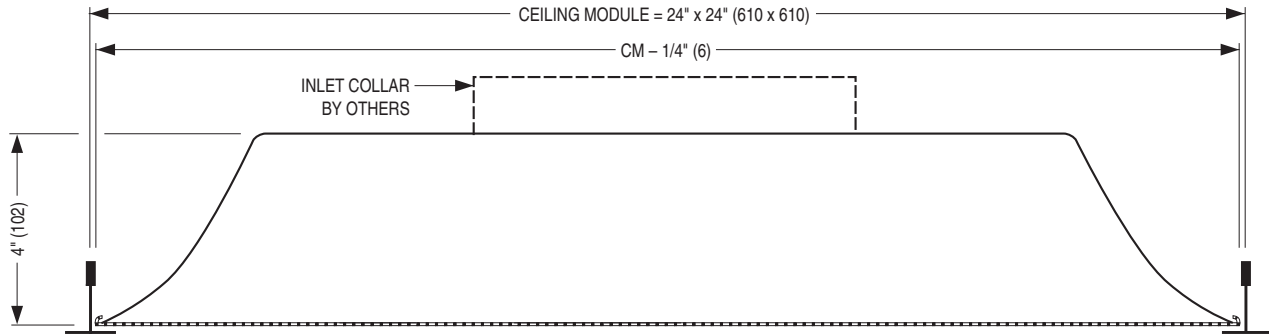

TYPE S Surface Mount

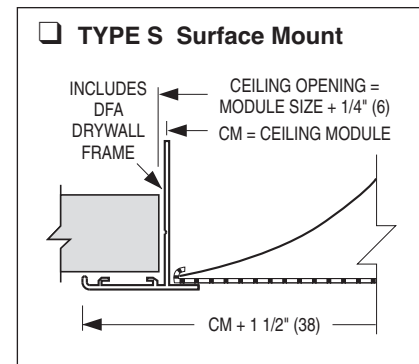

DESCRIPTION:

1. Corrosion-resistant steel diffuser face. One piece molded fiberglass backpan with foil back vapour barrier. 6.0 R-value.
2. Diffuser features a smoothly contoured back pan and wrap around fixed perforated face. Designed to match supply model 4350 in appearance, except pattern controllers are omitted.
3. Perforated face has 3/16" (5) diameter holes on 1/4" (6) staggered centers. 51% free area.
4. Pre-scored plenum for 6", 8", 10", 12", 14" or 15" (152, 203, 254, 305, 356 or 381) spin-in or tab-lock inlet collar (by others) for ducted return applications.
5. Standard finish is AW Appliance White face and black interior.

OPTIONS:

Finish:
 SP Special _____

SCHEDULE TYPE:		Dimensions are in inches (mm).			
PROJECT:					
ENGINEER:	DATE	B SERIES	SUPERSEDES	DRAWING NO.	
CONTRACTOR:	2 - 6 - 17	4300	1 - 7 - 11	4350R	



PERFORATED CEILING DIFFUSERS
 RETURN • FLUSH FACE • SQUARE NECK (FULL SIZE)
MODELS: 4360, 4360A, 4360AA

TYPE L Lay-in T-Bar

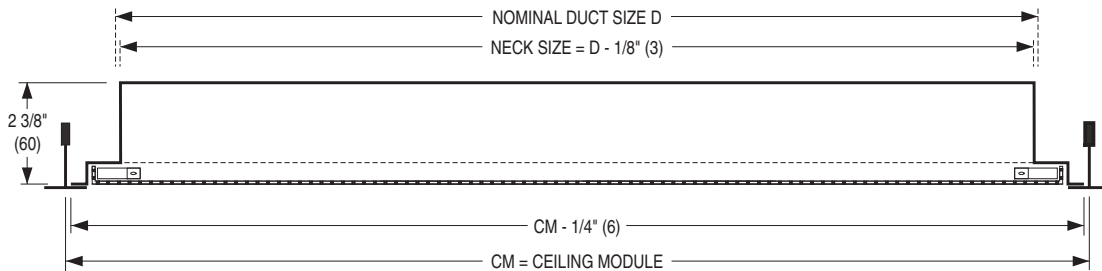

Imperial Module & Metric Module Table

Ceiling Module CM		Nominal Duct Size D	
Imperial Modules	Metric Modules	Square Neck	
		Imperial Units (inches)	Metric Units (mm)
12 x 12	300 x 300	10 x 10	250 x 250
24 x 12	600 x 300	22 x 10	550 x 250
20 x 20	500 x 500	18 x 18	450 x 450
24 x 24	600 x 600	22 x 22	550 x 550
48 x 24	1200 x 600	46 x 22	1150 x 550

DESCRIPTION:

1. Material: Corrosion-resistant steel. (Model 4360 is standard).
2. Designed to match supply air models 4320, 4320CB, 4320F and 4320M in appearance and construction detail, except that the air pattern controllers are not required and are omitted. This version is for ducted or ductless return applications. Features a dedicated frame assembly which has a neck that is 2" (51) less than the ceiling module size for maximum free area.
3. Removable face has concealed latches for easy access to optional damper.
4. Perforated face has 3/16" (5) diameter holes on 1/4" (6) staggered centres.
5. Standard finish is AW Appliance White.

OPTIONS:

- Aluminum perforated face/steel backpan. (Model 4360A).
- Aluminum perforated face and backpan. (Model 4360AA).
Finish:
- BA Black back pan with Appliance White face.
- SP Special _____.

Dimensions are in inches (mm).

Fineline® is a registered trademark of USG Interiors Inc.

TYPE S Surface Mount

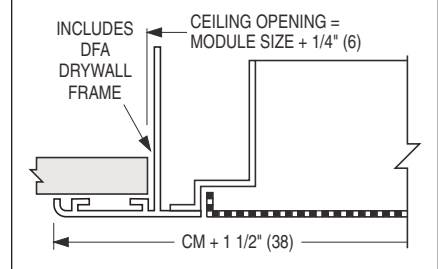

TYPE F Fineline® T-Bar

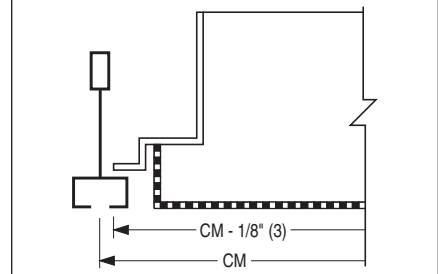

TYPE SP Spline

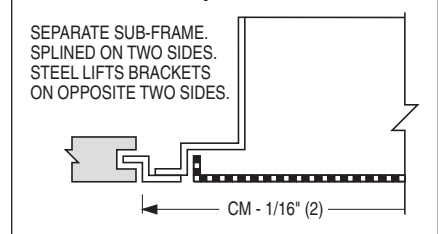

TYPE M Metal Pan (Snap-in)

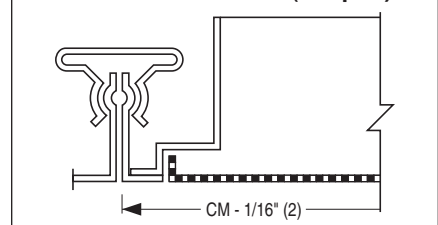

SCHEDULE TYPE:

PROJECT:

ENGINEER:

CONTRACTOR:

DATE

B SERIES

SUPERSEDES

DRAWING NO.

2 - 6 - 17

4300

3 - 7 - 16

4360-1



PERFORATED CEILING DIFFUSERS
 RETURN • FLUSH FACE • ROUND OR SQUARE NECK
MODELS: 4360, 4360A, 4360AA

TYPE L Lay-in T-Bar

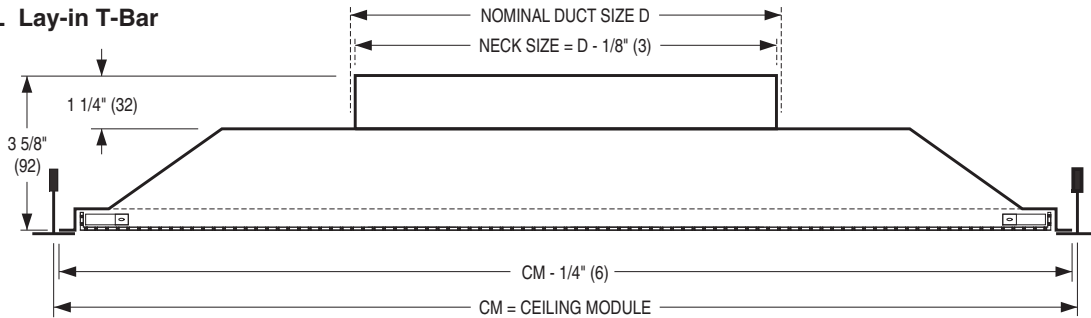

Available Combinations of Ceiling Module vs. Neck Size

Ceiling Module CM		Nominal Duct Size D			
Imperial Modules	Metric Modules	Round Neck		Square Neck	
		Imperial Units (inches)	Metric Units (mm)	Imperial Units (inches)	Metric Units (mm)
12 x 12	300 x 300	6, 8	152, 203	6 x 6, 8 x 8	152 x 152, 203 x 203
16 x 16	400 x 400	6, 8, 10, 12	152, 203, 254, 305	6 x 6, 8 x 8, 10 x 10, 12 x 12	152 x 152, 203 x 203, 254 x 254, 305 x 305
24 x 12	600 x 300	6, 8	152, 203	6 x 6, 8 x 8, 18 x 6	152 x 152, 203 x 203, 457 x 152
20 x 20	500 x 500	6, 8, 10, 12, 14	152, 203, 254, 305, 356	6 x 6, 8 x 8, 10 x 10, 12 x 12, 14 x 14	152 x 152, 203 x 203, 254 x 254, 305 x 305, 356 x 356
24 x 24	600 x 600	6, 8, 10, 12, 14, 15, 16, 18	152, 203, 254, 305, 356, 381, 406, 457	6 x 6, 8 x 8, 10 x 10, 12 x 12, 14 x 14, 15 x 15, 16 x 16, 18 x 18	152 x 152, 203 x 203, 254 x 254, 305 x 305, 356 x 356, 381 x 381, 406 x 406, 457 x 457
48 x 24	1200 x 600	6, 8, 10, 12, 14, 15, 16, 18	152, 203, 254, 305, 356, 381, 406, 457	6 x 6, 8 x 8, 10 x 10, 12 x 12, 14 x 14, 15 x 15, 16 x 16, 18 x 18	152 x 152, 203 x 203, 254 x 254, 305 x 305, 356 x 356, 381 x 381, 406 x 406, 457 x 457

DESCRIPTION:

1. Material: Corrosion-resistant steel. (Model 4360 is standard).
2. Designed to match supply air models 4320, 4320CB, 4320F and 4320M in appearance and construction detail, except that the air pattern controllers are not required and are omitted. This version is for ducted return applications; for connection to flexible or rigid round duct or square duct.
3. Removable face has concealed latches for easy access to optional damper.
4. Perforated face has 3/16" (5) diameter holes on 1/4" (6) staggered centres.
5. Standard finish is AW Appliance White.

OPTIONS:

- Aluminum perforated face/steel backpan. (Model 4360A).
- Aluminum perforated face and backpan. (Model 4360AA).
- EX External Foil-Back Insulation, installed - R-4.2 (24 x 24 max.).
- EXB External Foil-Back Insulation, ships loose - R-4.2 (24 x 24 max.).
- MIB Molded Insulation Blanket - R-6.0 (24 x 24 only).

Finish:

- BA Black back pan with Appliance White face.
- SP Special _____.

Fineline® is a registered trademark of USG Interiors Inc.

TYPE S Surface Mount

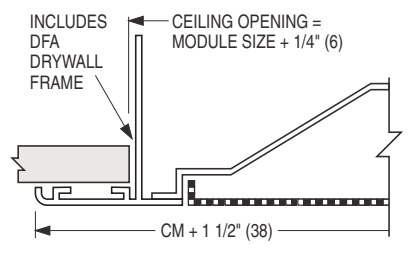

TYPE F Fineline® T-Bar

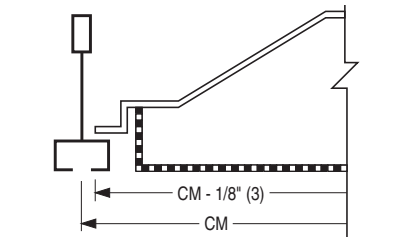

TYPE SP Spline

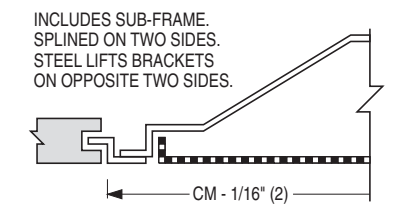

TYPE M Metal Pan (Snap-in)

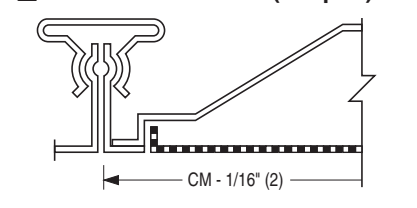

Dimensions are in inches (mm).

SCHEDULE TYPE:					
PROJECT:					
ENGINEER:		DATE	B SERIES	SUPERSEDES	DRAWING NO.
CONTRACTOR:		3 - 10 - 16	4300	5 - 11 - 15	4360-2



PERFORATED CEILING DIFFUSERS
 RETURN • DROP FACE • SQUARE NECK (FULL SIZE)
MODELS: 4365, 4365A, 4365AA

TYPE L Lay-in T-Bar

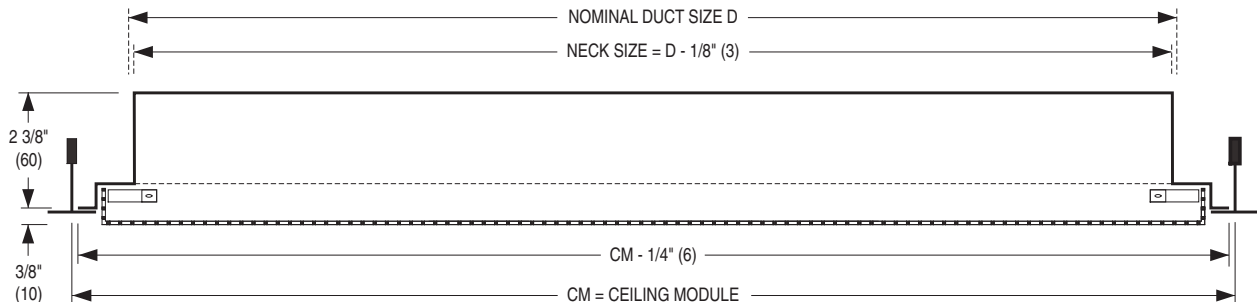

Imperial Module & Metric Module Table

Ceiling Module CM		Nominal Duct Size D	
Imperial Modules	Metric Modules	Square Neck	
		Imperial Units (inches)	Metric Units (mm)
12 x 12	300 x 300	10 x 10	250 x 250
24 x 12	600 x 300	22 x 10	550 x 250
20 x 20	500 x 500	18 x 18	450 x 450
24 x 24	600 x 600	22 x 22	550 x 550
48 x 24	1200 x 600	46 x 22	1150 x 550

DESCRIPTION:

1. Material: Corrosion-resistant steel.
2. Designed to match supply air models 4320, 4320CB, 4320F and 4320M in appearance and construction detail, except that the air pattern controllers are not required and are omitted. This version is for ducted or ductless return applications. Features a dedicated frame assembly which has a neck that is 2" (51) less than the ceiling module size for maximum area.
3. Removable face has concealed latches for easy access to optional damper.
4. Perforated face has 3/16" (5) diameter holes on 1/4" (6) staggered centres.
5. Standard finish is AW Appliance White.

OPTIONS:

- Aluminum perforated face/steel backpan. (Model 4365A).
- Aluminum perforated face and backpan. (Model 4365AA).
- Finish:
- BA Black back pan with Appliance White face.
- SP Special _____.

TYPE S Surface Mount

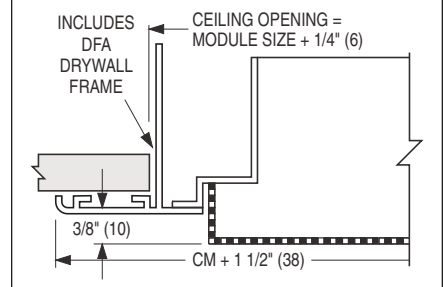

TYPE SP Spline

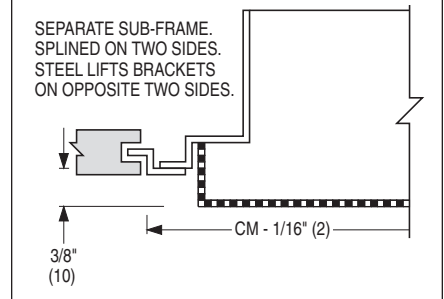

TYPE M Metal Pan (Snap-in)

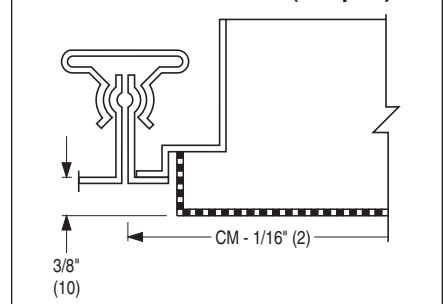

Dimensions are in inches (mm).

SCHEDULE TYPE:
PROJECT:
ENGINEER:
CONTRACTOR:

DATE	B SERIES	SUPERSEDES	DRAWING NO.
2 - 6 - 17	4300	3 - 10 - 16	4365-1



PERFORATED CEILING DIFFUSERS
 RETURN • DROP FACE • ROUND OR SQUARE NECK
MODELS: 4365, 4365A, 4365AA

TYPE L Lay-in T-Bar

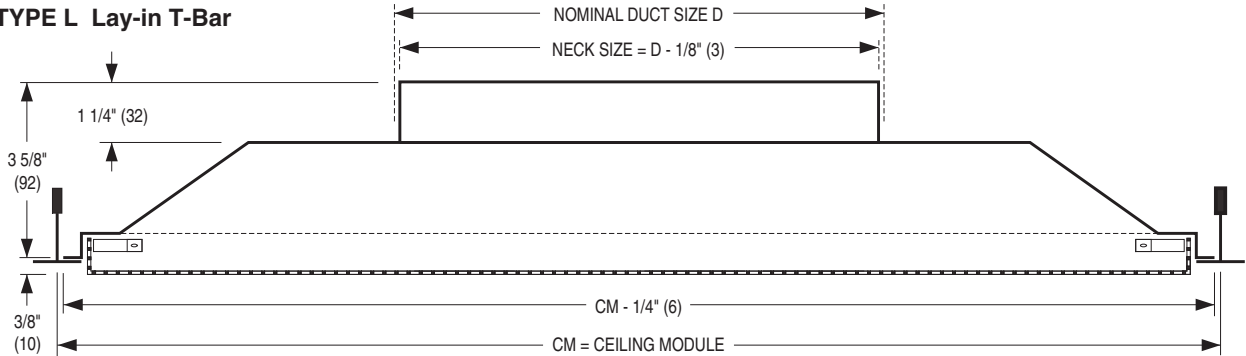

Available Combinations of Ceiling Module vs. Neck Size

Ceiling Module CM		Nominal Duct Size D			
Imperial Modules	Metric Modules	Round Neck		Square Neck	
		Imperial Units (inches)	Metric Units (mm)	Imperial Units (inches)	Metric Units (mm)
12 x 12	300 x 300	6, 8	152, 203	6 x 6, 8 x 8	152 x 152, 203 x 203
16 x 16	400 x 400	6, 8, 10, 12	152, 203, 254, 305	6 x 6, 8 x 8, 10 x 10, 12 x 12	152 x 152, 203 x 203, 254 x 254, 305 x 305
24 x 12	600 x 300	6, 8	152, 203	6 x 6, 8 x 8, 18 x 6	152 x 152, 203 x 203, 457 x 152
20 x 20	500 x 500	6, 8, 10, 12, 14	152, 203, 254, 305, 356	6 x 6, 8 x 8, 10 x 10, 12 x 12, 14 x 14	152 x 152, 203 x 203, 254 x 254, 305 x 305, 356 x 356
24 x 24	600 x 600	6, 8, 10, 12, 14, 15, 16, 18	152, 203, 254, 305, 356, 381, 406, 457	6 x 6, 8 x 8, 10 x 10, 12 x 12, 14 x 14, 15 x 15, 16 x 16, 18 x 18	152 x 152, 203 x 203, 254 x 254, 305 x 305, 356 x 356, 381 x 381, 406 x 406, 457 x 457
48 x 24	1200 x 600	6, 8, 10, 12, 14, 15, 16, 18	152, 203, 254, 305, 356, 381, 406, 457	6 x 6, 8 x 8, 10 x 10, 12 x 12, 14 x 14, 15 x 15, 16 x 16, 18 x 18	152 x 152, 203 x 203, 254 x 254, 305 x 305, 356 x 356, 381 x 381, 406 x 406, 457 x 457

DESCRIPTION:

1. Material: Corrosion-resistant steel.
2. Designed to match supply air models 4320, 4320CB, 4320F and 4320M in appearance and construction detail, except that the air pattern controllers are not required and are omitted. This version is for ducted return applications; for connection to flexible or rigid round duct or square duct.
3. Removable face has concealed latches for easy access to optional damper.
4. Perforated face has 3/16" (5) diameter holes on 1/4" (6) staggered centres.
5. Standard finish is AW Appliance White.

OPTIONS:

- Aluminum perforated face/steel backpan. (Model 4365A).
 - Aluminum perforated face and backpan. (Model 4365AA).
 - EX External Foil-Back Insulation, installed - R-4.2 (24 x 24 max.).
 - EXB External Foil-Back Insulation, ships loose - R-4.2 (24 x 24 max.).
 - MIB Molded Insulation Blanket - R-6.0 (24 x 24 only).
- Finish:
- BA Black back pan with Appliance White face.
 - SP Special _____.

TYPE S Surface Mount

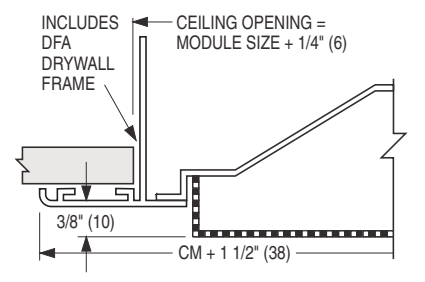

TYPE SP Spline

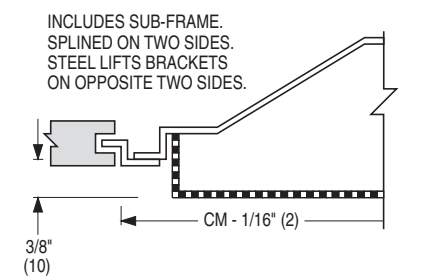

TYPE M Metal Pan (Snap-in)

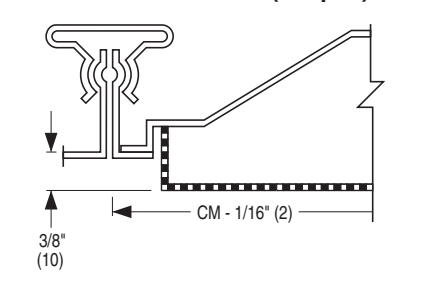

Dimensions are in inches (mm).

SCHEDULE TYPE:

PROJECT:

ENGINEER:

CONTRACTOR:

DATE

B SERIES

SUPERSEDES

DRAWING NO.

3 - 10 - 16

4300

5 - 11 - 15

4365-2

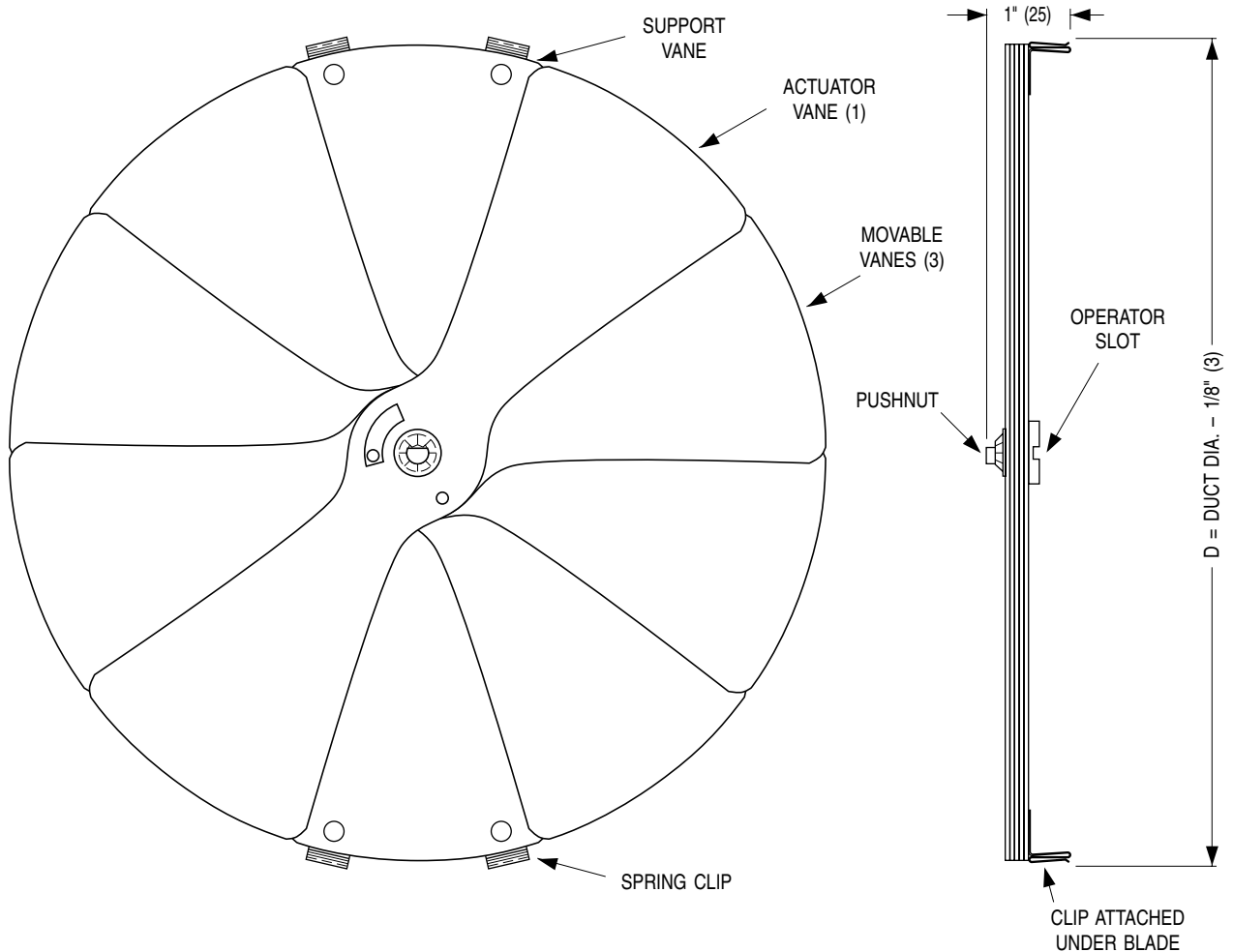
DESCRIPTION:

1. Material: Heavy gauge corrosion-resistant steel.
2. The Nailor Model 4250 is a neck mounted, radial sliding blade damper used in round neck diffuser applications to provide fine volume control.
3. Dampers have gang operated radial blades. Blades slide at right angles to the duct with protrusion above the diffuser neck, allowing the damper to work effectively in flexible duct applications.
4. The 4250 is neck mounted with steel barb clips providing secure attachment.
5. Adjustments are made at the screwdriver operator slot.
6. Available Sizes: 6", 8", 10", 12" and 14" (152, 203, 254, 305 and 356) dia..

SCHEDULE TYPE:
PROJECT:
ENGINEER:
CONTRACTOR:

Dimensions are in inches (mm).

DATE
B SERIES
SUPERSEDES
DRAWING NO.

10 - 24 - 01

ACC.DIF.

25 - 8 - 99R

ABD-4250



AIR BALANCING DEVICE RADIAL OPPOSED BLADE DAMPER STEEL • FOR ROUND NECK DIFFUSERS MODEL: 4275 (5" - 16" DIA.)

DESCRIPTION:

A unique method of controlling volume through a diffuser providing premium design quality and performance. The multi-blade perimeter design offers true radial flow at any setting.

A screwdriver slot, accessible through the diffuser, requires only a half turn to adjust from fully closed to fully open. The damper is designed to fit directly on the neck of the diffuser. Simple convenient and accurate installation and operation.

OPERATION:

Size 5 through 8 are friction type. Use screwdriver and turn operator to adjust damper setting.

Size 10 through 16 use a detent mechanism to positively hold damper setting. Using screwdriver, lift up and turn operator to desired damper setting.

1. Material: Corrosion-resistant steel construction.
2. Damper mounts directly to diffuser collar.
3. Standard Finish: Mill.

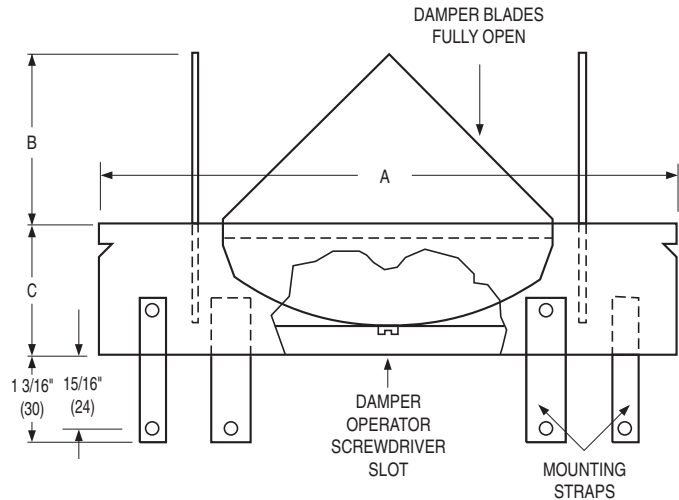
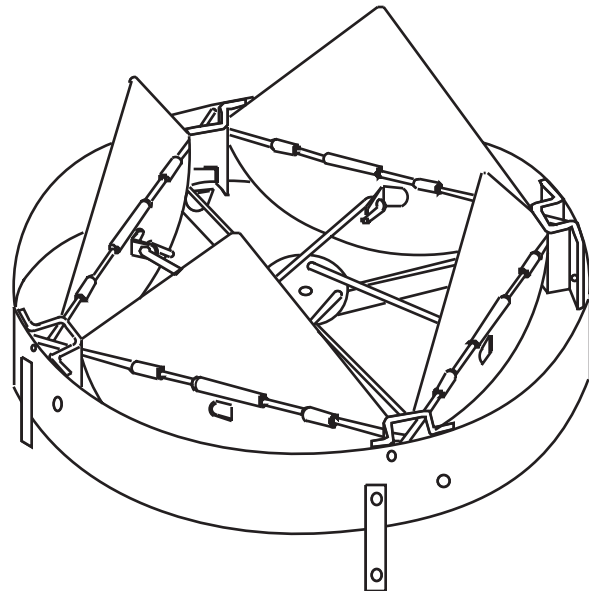

	Nominal Size (inches)								Nominal Size (mm)							
	5	6	8	10	12	14	15	16	127	152	203	254	305	356	381	406
A	4 7/8	5 7/8	7 7/8	9 7/8	11 7/8	13 7/8	14 7/8	15 7/8	124	149	200	251	302	352	378	403
B	1 1/8	1 5/8	2 1/2	2 1/4	2 7/8	3 3/8	3 3/4	4 3/8	29	41	64	57	73	86	95	111
C	1 5/8				2 1/2				41				64			

SCHEDULE TYPE:

PROJECT:

ENGINEER:

CONTRACTOR:

Dimensions are in inches (mm).

DATE

B SERIES

SUPERSEDES

DRAWING NO.

8 - 29 - 05

ABD

3 - 1 - 02

ABD-4275-1



**AIR BALANCING DEVICE
RADIAL OPPOSED BLADE DAMPER
STEEL • FOR ROUND NECK DIFFUSERS
MODEL: 4275 (18" DIA.)**

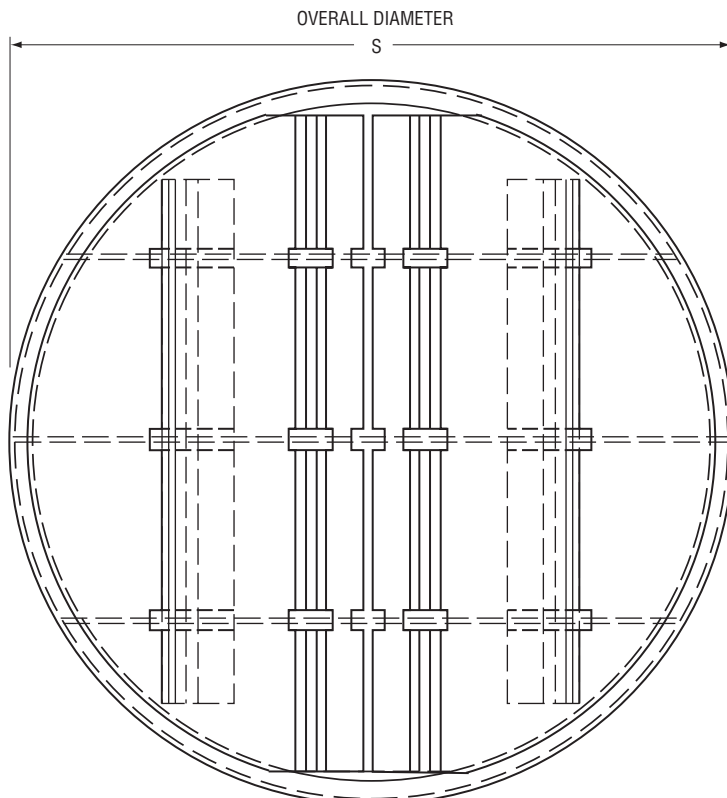

**TOP VIEW
VALVES CLOSED**

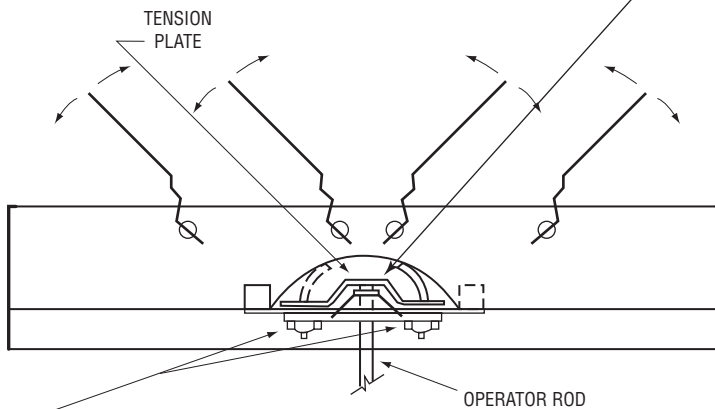
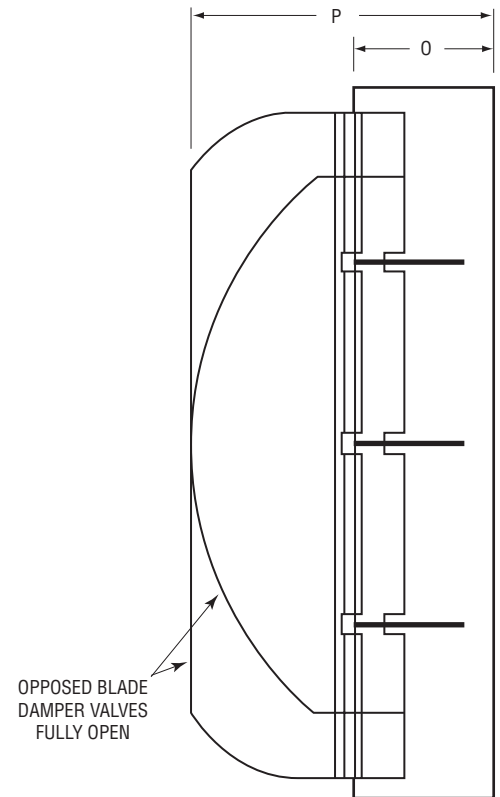

**CROSS SECTION WITH VALVES PARTLY OPEN
SHOWING OPPOSED BLADE OPERATION.**

IF OPERATOR IS TO BE REMOVED AFTER SETTING DAMPER, DO NOT DRIVE INTO TENSION PLATE AS THIS LOCKS ROD IN PLACE FOR PERMANENT INSTALLATION.

LOCK NUTS:
LOOSEN BEFORE ADJUSTING DAMPER.
TIGHTEN AFTER ADJUSTING DAMPER TO PROVIDE POSITIVE LOCK.

DESCRIPTION:

1. Material: Steel construction.
2. Screw or rivet to duct.
3. Opposed blade operation.
4. Finish: Black.

List Dia.	Imperial Modules			Metric Modules		
	Imperial Units (inches)			SI Units (mm)		
18"	S	O	P	S	O	P
	17 7/8	1 3/4	4 3/4	454	44	121

SCHEDULE TYPE:
PROJECT:
ENGINEER:
CONTRACTOR:

Dimensions are in inches (mm).

DATE	B SERIES	SUPERSEDES	DRAWING NO.
11 - 26 - 07	4200	8 - 30 - 05	ABD-4275-3



**AIR BALANCING DEVICE
BUTTERFLY DAMPER
STEEL • FOR ROUND NECK DIFFUSERS
MODEL: 4675**

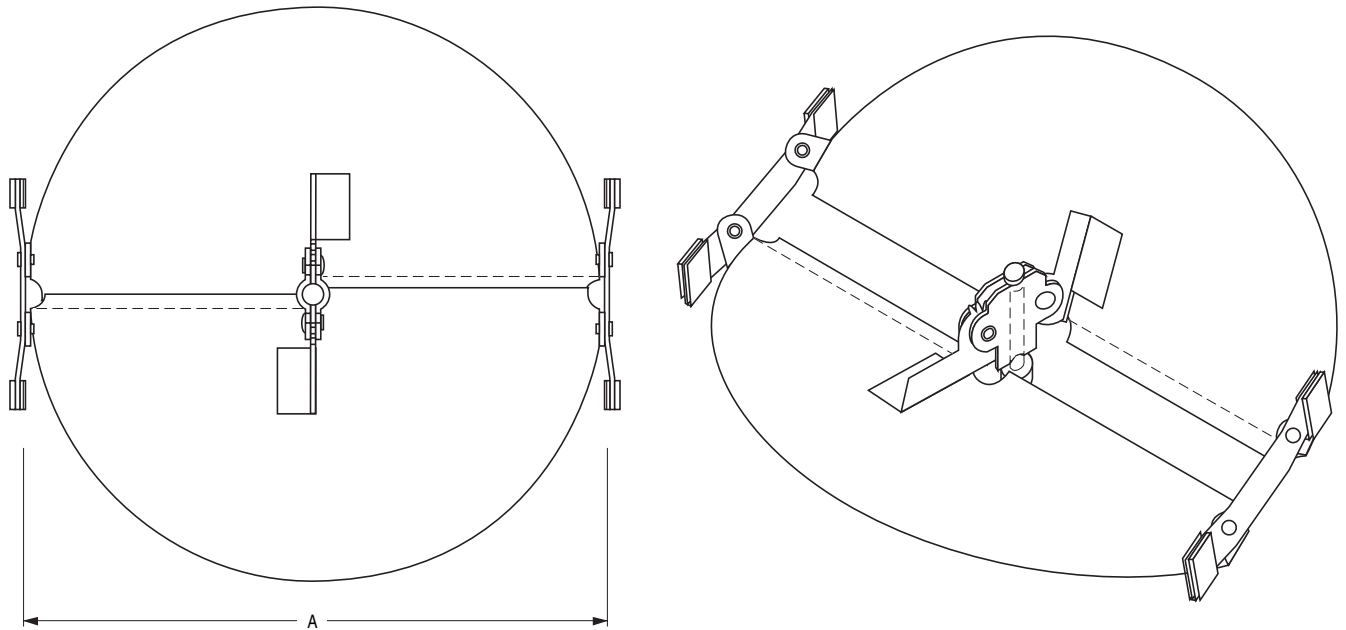

DESCRIPTION:

The Model 4675 Butterfly Damper is an economical damper for volume balancing in round neck diffusers. Adjustable friction pivots hold the blades at the required setting.

1. Material: Corrosion-resistant steel. Mill finish.
2. The 4675 damper mounts directly to diffuser collar. Not compatible with Model Series RNSA, RNR, RNRA1, 6300 or 6300R diffusers.
3. Screwdriver slot operator is adjustable from the face of the diffuser.

	Nominal Size (inches)					Nominal Size (mm)				
	6	8	10	12	14	152	203	254	305	356
A	5 7/8	7 7/8	9 7/8	11 7/8	13 7/8	149	200	251	302	352
B	2 1/2	3 1/2	4 1/2	5 1/2	6 1/2	64	89	114	140	165

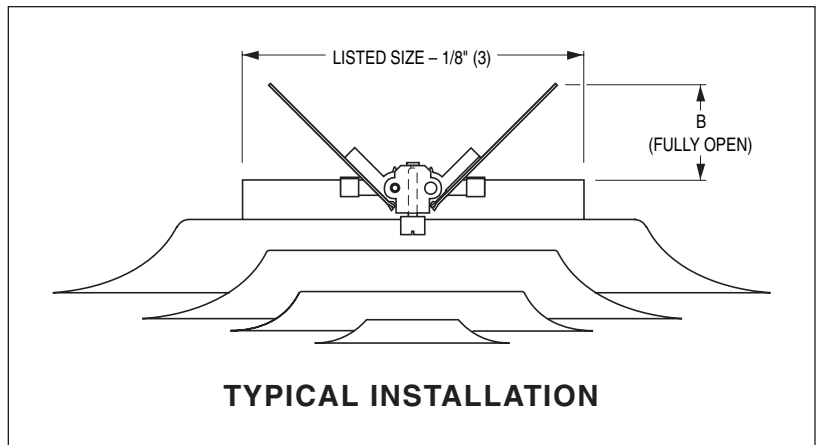

TYPICAL INSTALLATION

SCHEDULE TYPE:					Dimensions are in inches (mm).				
PROJECT:									
ENGINEER:					DATE	B SERIES	SUPERSEDES	DRAWING NO.	
CONTRACTOR:					11 - 14 - 08	ACC.DIF.	5 - 28 - 08	ABD-4675	



**AIR BALANCING DEVICES
OPPOSED BLADE DAMPER • NECK MOUNTED
FOR SQUARE AND RECTANGULAR NECKS
MODEL: OBD TYPE SL & PL**

TYPE SL Screwdriver Slot Face Operator (Standard)

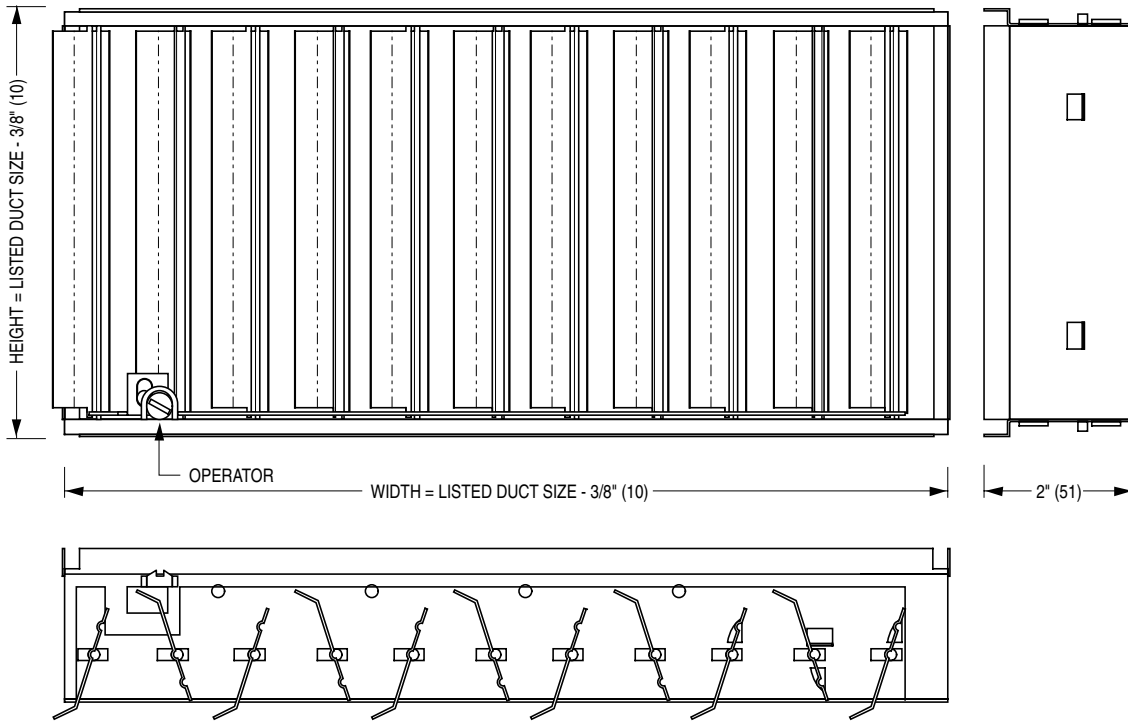

OBD-L Long Blades

OBD-S Short Blades

Minimum Size = 4" x 2 1/2" (102 x 64)

Maximum Size = 24" x 24" (610 x 610)

DESCRIPTION:

1. Material: Roll-formed, corrosion-resistant steel. Mill finish.
2. Designed to mount directly on the neck of a grille or diffuser in square and rectangular neck applications. Supplied with steel barbed S-clips for easy field mounting. Supplied as standard with a screwdriver slot operator.
3. Gang operated blades on 1" (25) centers move simultaneously in opposite directions and close at 45° to permit precise metering of the air with a minimal disturbance to the air pattern.

SPECIAL FEATURES:

_____.

OPTIONS:

Type PL Pivot Lever Operator.

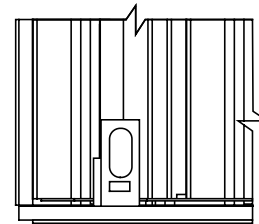

For fixed, angled deflection return grilles. Blade orientation of damper must be opposite of grille. Adjusted with a screwdriver.

SCHEDULE TYPE:		Dimensions are in inches (mm).			
PROJECT:					
ENGINEER:	DATE	B SERIES	SUPERSEDES	DRAWING NO.	
CONTRACTOR:	26 - 8 - 99RR	ACC.DIF/GR	6-94/5100-21	ACC.ABD-1	



**AIR BALANCING DEVICES
OPPOSED BLADE DAMPER • DUCT MOUNTED
FOR SQUARE AND RECTANGULAR NECKS
MODEL: OBD-A TYPE SL & PL**

TYPE SL Screwdriver Slot Face Operator (Standard)

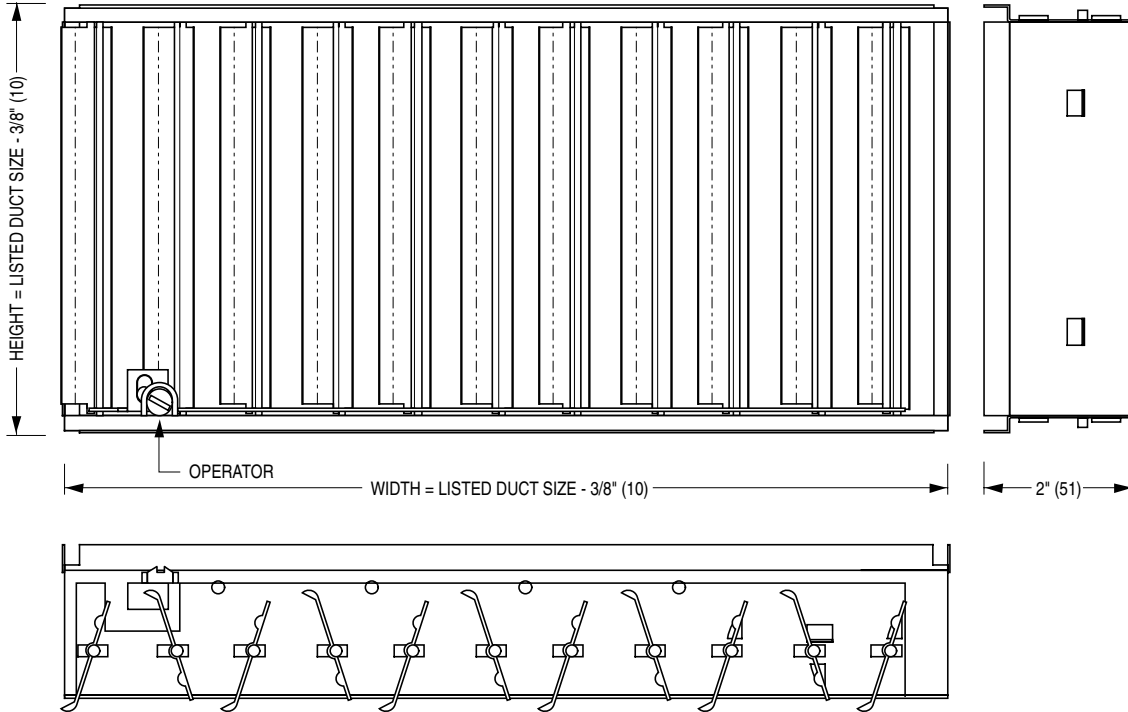

OBD-A-L Long Blades

OBD-A-S Short Blades

Minimum Size = 4" x 2 1/2" (102 x 64)

Maximum Size = 24" x 24" (610 x 610)

DESCRIPTION:

1. Material: Heavy gauge, extruded aluminum with miscellaneous steel components. Mill finish.
2. Designed to mount directly on the neck of a grille or diffuser in square and rectangular neck applications. Supplied with steel barbed S-clips for easy field mounting. Supplied as standard with a screwdriver slot operator.
3. Gang operated blades on 1" (25) centers move simultaneously in opposite directions and close at 45° to permit precise metering of the air with a minimal disturbance to the air pattern.

SPECIAL FEATURES:

_____.

OPTIONS:

Type PL Pivot Lever Operator.

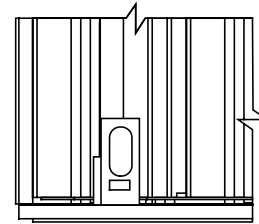

For fixed, angled deflection return grilles. Blade orientation of damper must be opposite of grille. Adjusted with a screwdriver.

SCHEDULE TYPE:		Dimensions are in inches (mm).			
PROJECT:					
ENGINEER:	DATE	B SERIES	SUPERSEDES	DRAWING NO.	
CONTRACTOR:	26 - 8 - 99RR	ACC.DIF/GR	NEW	ACC.ABD-2	



**MOLDED INSULATION BLANKET
CEILING DIFFUSER ACCESSORY
24" x 24" MODULE FOR CEILING DIFFUSERS
MODEL/ACCESSORY: MIB**

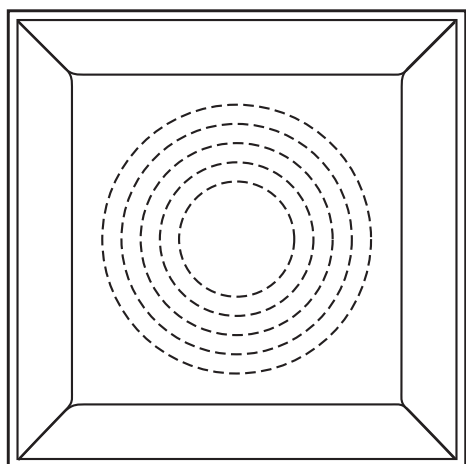
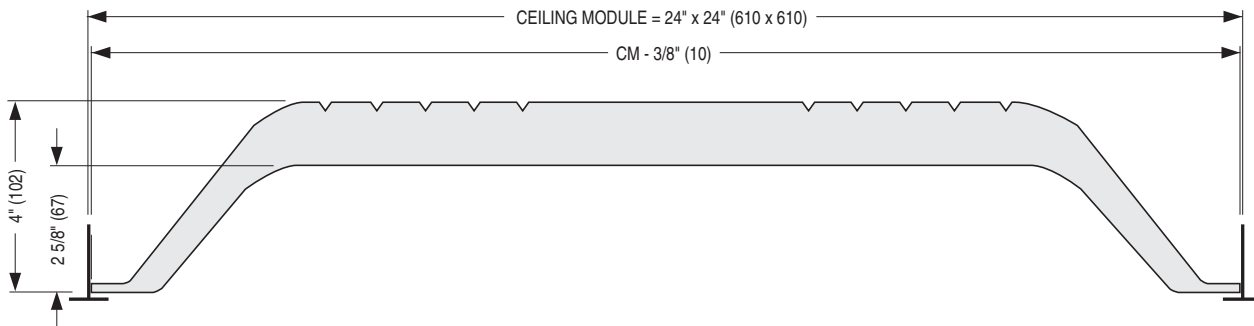

DESCRIPTION:

1. One piece molded fiberglass insulation blanket with foil back vapour barrier. 6.0 R-value.
2. Pre-scored plenum 6", 8", 10", 12" or 14" (152, 203, 254, 305 or 356) dia. for field cutting.
3. The Nailor Model MIB fits over the backpan of most full face 24" x 24" diffusers and provides thermal protection to reduce the risk of condensation forming on the diffuser face.
Compatible models include RNS, RNS2, RNS3, UNI, 6200, 6400, 6500 and 4320 series.
4. The Nailor Model MIB: resists ageing, thermal shock, is incombustible, immune to rot, corrosion, oxidation and insects.
5. Tested in compliance with surface burning characteristics (ASTM E-84) and erosion test (UL 181).
6. Standard finish has a black interior.

SCHEDULE TYPE:		Dimensions are in inches (mm).			
PROJECT:					
ENGINEER:	DATE	B SERIES	SUPERSEDES	DRAWING NO.	
CONTRACTOR:	1 - 16 - 17	MIB	2 - 1 - 11	MIB-1	

Nailor offers a selection of standard colors and finishes available on our grilles, registers and diffusers. For painted finishes, our state-of-the-art paint systems provide environmentally friendly finishing solutions with uniform coverage and coating thickness. The result is an exceptionally durable finish that resists scratching, corrosion and general wear. Additional facilities for special requirements, as well as a selection of anodized or brushed finishes, complete our ability to provide unmatched beauty and durability for any application.

NAILOR POWDER COAT PROPERTIES

FILM THICKNESS	2.0 to 3.0 mils
HARDNESS	2 H
IMPACT RESISTANCE	Direct: 160 inch - lbs. Reverse 160 inch - lbs.
SALT SPRAY	1000 hours

ELECTROCOATING PROPERTIES

FILM THICKNESS	.8 to 1.2 mils
HARDNESS	HB TO H
IMPACT RESISTANCE	80 inch - lbs
SALT SPRAY	100 hours

POWDER COAT

Nailor's powder coat is a high-tech thermosetting polyester powder coating with superior physical properties that provide excellent color and gloss retention. The finish offers extreme durability and hardness that resists scratching, chipping and general wear. Surface preparation includes degreasing and a chemical cleaning followed by a clean rinse before a final powder coat finish is applied and baked. The environmentally friendly Nailor powder coat system assures uniform coverage and color consistency resulting in a long lasting superior finish. Colors, including simulated anodizing, which is far more economical than color anodizing, can be selected from Nailor's standard color chart or non-standard colors and can be matched from sample chips provided to Nailor.

ELECTROCOATING

E-Coat is an environmentally friendly coating that provides complete coverage and a wide range of performance properties, formulated to meet corrosion, durability and other performance specifications. Electrocoating is a highly automated process in which paint is electrically deposited onto a metal foundation. Film build thickness is uniform and overall application efficiencies are in excess of 90%. Paint is consistent on all part-to-part surfaces, preventing sags, runs or drips. E-Coat offers flexibility, better first yield pass and quicker production times compared to other forms of paint applications. Electrocoating is an excellent solution that offers superior properties and uniform finish.

CLEAR ANODIZING (Aluminum products only)

Clear anodizing is a clear oxide coating that exemplifies an aluminum surface's natural oxide coating producing a hard, scratch resistant surface that is resistant to general wear and mild chemicals. The process provides a natural looking, virtually maintenance free finish that will endure for many years.

COLOR ANODIZING (Aluminum products only)

Color anodizing is an electrolytic process where, after standard anodizing procedures, colored metallic pigments penetrate the oxide surface pores producing a corrosion resistant, colorfast finish. The process results in a natural metallic appearance that requires little maintenance.

BRUSHED AND CLEAR COAT

Available on specific aluminum products (consult applicable product page for availability). Surface is brushed to achieve a scratch finish texture before being degreased and chemically cleaned. A clear lacquer coating is then applied to provide a durable protective finish.

#4 BRUSHED SATIN POLISHED (Stainless Steel products only)

Surface is polished to ASTM A480 #4 standard to achieve a bright durable finish that is resistant to mild chemicals and corrosion. A final coating is not required due to the inherent anti-corrosion properties of the stainless steel.

PRIME COAT

Prime coat provides a stable base for painting in the field. Surface pretreatment includes degreasing and a chemical cleaning before an alkyd prime coat is applied. After a thorough cleaning for dust, etc. that can contaminate the final finish and cause premature flaking or peeling, finish coat should be field applied as soon as possible.

PAINT PREPARED ALUMINUM (Aluminum products only)

Allows for field applied paint. Surface preparation includes degreasing and a chemical cleaning followed by a clean rinse. Finish coat should be field applied as soon as possible.

MILL FINISH

Surface is left untreated and requires cleaning, degreasing, etc. in the field before final finish can be applied if required.



Nailor[®]
Industries Inc.

STANDARD AND OPTIONAL FINISHES FOR GRILLES AND DIFFUSERS

The following standard colors and finishes are available on applicable Nailor air distribution products. Consult individual product pages for availability

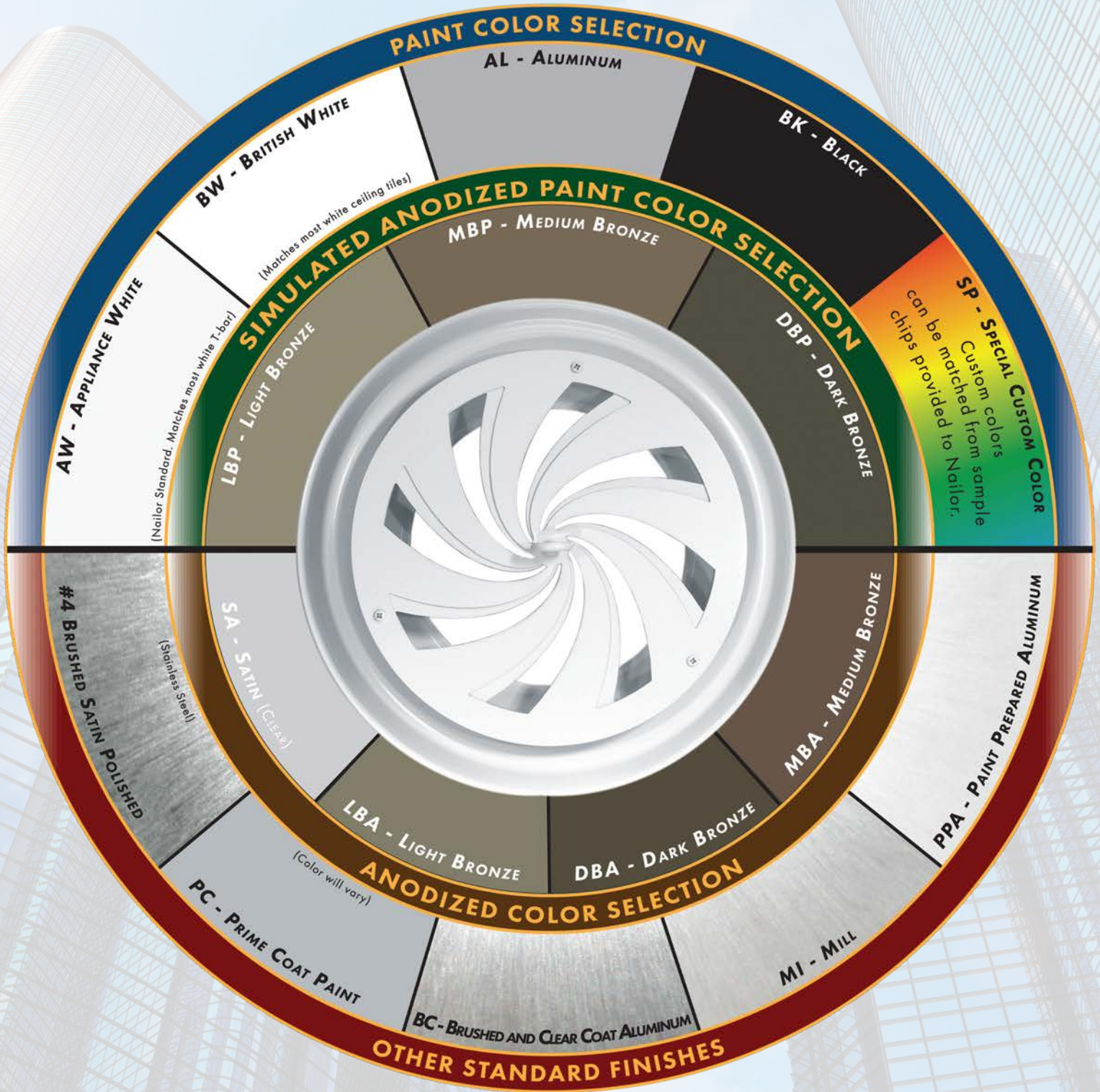

The pictured finishes have been represented as best as possible within printing limitations. However, actual finish may vary. Contact your Nailor representative for a color chip sample on the material specified for a more accurate representation.

DBK - Black (for registers ordered with factory mounted dampers) - **BA** - Perforated Diffusers (4300 series only) Appliance White (AW) face with black back pan and pattern controllers.

"Complete Air Control and Distribution Solutions."

WGDSOF2015

www.nailor.com

PERFORMANCE DATA:

Models 4360, 4360A, 4360AA • Flush Face • Return Module
 4365, 4365A, 4365AA • Drop Face • Return Module

Ceiling Module	Neck Size	Neck Velocity, FPM	300	400	500	600	700	800	1000	1200	1400	
		Negative Static Pressure	.024	.042	.067	.096	.130	.170	.266	.383	.522	
		Velocity Pressure	.006	.010	.016	.022	.031	.040	.062	.090	.122	
12 x 12	6" Dia.	Airflow, CFM	59	78	98	118	137	157	196	236	275	
		Noise Criteria	—	—	—	10	14	18	27	32	38	
	8 x 8	Airflow, CFM	75	100	125	150	175	200	250	300	350	
		Noise Criteria	—	—	—	12	17	21	30	35	41	
	8" Dia.	Airflow, CFM	105	140	175	209	244	279	349	419	489	
		Noise Criteria	—	—	10	16	21	25	32	39	44	
	8 x 8	Airflow, CFM	133	178	222	267	311	356	444	533	622	
		Noise Criteria	—	—	11	17	22	26	33	40	45	
	10 x 10	Airflow, CFM	208	278	347	416	486	556	694	833	972	
		Noise Criteria	—	—	18	24	29	33	40	47	52	
	20 x 20	18 x 18	Airflow, CFM	675	900	1125	1350	1575	1800	2250	2700	3150
			Noise Criteria	—	17	24	30	35	39	46	53	58
24 x 12	6" Dia.	Airflow, CFM	75	100	125	150	175	200	250	300	350	
		Noise Criteria	—	—	—	13	18	22	29	36	41	
	8" Dia.	Airflow, CFM	105	140	175	209	244	279	349	419	489	
		Noise Criteria	—	—	—	15	20	24	31	38	43	
	8 x 8	Airflow, CFM	133	178	222	267	311	356	444	533	622	
		Noise Criteria	—	—	10	16	21	25	32	39	44	
	18 x 6	Airflow, CFM	225	300	375	450	525	600	750	900	1050	
		Noise Criteria	—	—	14	20	25	28	35	42	47	
	22 x 10	Airflow, CFM	458	611	764	917	1069	1222	1528	1833	2139	
		Noise Criteria	—	15	21	27	34	37	44	51	56	
	24 x 24	6" Dia.	Airflow, CFM	59	79	98	118	137	157	196	236	275
			Noise Criteria	—	—	—	10	15	19	26	33	38
6 x 6		Airflow, CFM	75	100	125	150	175	200	250	300	350	
		Noise Criteria	—	—	—	12	17	21	28	35	41	
8" Dia.		Airflow, CFM	105	140	175	209	244	279	349	419	489	
		Noise Criteria	—	—	—	14	19	23	30	37	42	
8 x 8		Airflow, CFM	133	178	222	267	311	356	444	533	622	
		Noise Criteria	—	—	—	15	20	24	31	38	43	
10" Dia.		Airflow, CFM	164	218	273	327	382	436	545	655	764	
		Noise Criteria	—	—	10	16	21	25	32	39	44	
10 x 10		Airflow, CFM	208	278	347	417	486	556	694	833	972	
		Noise Criteria	—	—	11	17	22	26	33	40	45	
12" Dia.		Airflow, CFM	236	314	393	471	550	628	785	942	1100	
		Noise Criteria	—	—	13	19	24	28	35	42	47	
12 x 12		Airflow, CFM	300	400	500	600	700	800	1000	1200	1400	
		Noise Criteria	—	—	14	20	25	29	36	43	48	
14" Dia.		Airflow, CFM	321	428	535	641	748	855	1069	1283	1497	
		Noise Criteria	—	—	15	21	26	30	37	44	49	
14 x 14		Airflow, CFM	408	544	681	817	953	1089	1361	1633	1906	
		Noise Criteria	—	10	17	23	28	32	39	46	51	
15 x 15		Airflow, CFM	469	625	781	938	1094	1250	1563	1875	2188	
		Noise Criteria	—	12	19	25	30	34	41	48	53	
16" Dia.		Airflow, CFM	419	559	698	838	977	1117	1396	1676	1955	
		Noise Criteria	—	10	17	23	28	32	39	46	51	
18" Dia.	Airflow, CFM	530	707	884	1060	1237	1414	1767	2121	2474		
	Noise Criteria	—	12	19	25	30	32	39	46	51		
18 x 18	Airflow, CFM	675	900	1125	1350	1575	1800	2250	2700	3150		
	Noise Criteria	—	16	23	29	34	38	45	52	57		
22 x 22	Airflow, CFM	1008	1344	1681	2017	2353	2689	3361	4033	4706		
	Noise Criteria	—	18	25	31	36	40	47	51	59		
48 x 24	46 x 22	Airflow, CFM	2108	2811	3514	4217	4919	5622	7028	8433	9839	
		Noise Criteria	11	20	27	34	38	43	50	57	62	

Performance Notes:

- All pressures are in inches w.g..
- Noise Criteria (NC) values are based

upon 10 dB room absorption, re 10⁻¹² watts. Dash (—) in space indicates an Noise Criteria of less than 10.

3. Data derived from tests conducted in accordance with ANSI/ASHRAE Standard 70 – 2006.

PERFORMANCE DATA:

Models 4302, 4302-DF, 4302-F, 4302A • Return Panel

Ceiling Module	Neck Velocity, FPM	200	300	400	500	600	700	800	900	1000
	Negative Static Pressure	.013	.029	.051	.080	.115	.157	.205	.259	.320
	Velocity Pressure	.002	.006	.010	.016	.023	.031	.040	.050	.063
12 x 12	Airflow, CFM	200	300	400	500	600	700	800	900	1000
	Noise Criteria	—	—	27	34	40	45	49	52	57
20 x 20	Airflow, CFM	556	833	1111	1389	1667	1944	2222	2500	2778
	Noise Criteria	—	—	24	30	37	42	46	49	54
24 x 12	Airflow, CFM	400	600	800	1000	1200	1400	1600	1800	2000
	Noise Criteria	—	17	27	32	39	44	48	52	56
24 x 24	Airflow, CFM	800	1200	1600	2000	2400	2800	3200	3600	4000
	Noise Criteria	—	16	24	31	37	41	45	48	53
48 x 24	Airflow, CFM	1600	2400	3200	4000	4800	5600	6400	7200	8000
	Noise Criteria	—	18	27	33	39	44	48	51	56

Performance Notes:

1. All pressures are in inches w.g..
2. Noise Criteria (NC) values are based upon 10 dB room absorption, re 10⁻¹² watts. Dash (—) in space indicates an Noise Criteria of less than 15.
3. Data derived from tests conducted in accordance with ANSI/ASHRAE Standard 70 – 2006.

PERFORMANCE DATA:

Models 4330R, 4330RA • Flush Face • Return Model

Ceiling Module	Neck Size	Neck Velocity, FPM	300	400	500	600	700	800	1000	1200	1400
		Negative Static Pressure	.024	.042	.067	.096	.13	.17	.266	.383	.522
		Velocity Pressure	.006	.01	.016	.023	.031	.04	.063	.09	.123
12 x 12	10 x 10	Airflow, CFM	208	277	347	416	485	555	694	832	971
		Noise Criteria	—	15	22	28	33	37	44	51	57
20 x 20	18 x 18	Airflow, CFM	675	900	1125	1350	1575	1800	2250	2700	3150
		Noise Criteria	—	17	24	30	35	39	46	53	58
24 x 12	22 x 10	Airflow, CFM	459	612	765	918	1071	1224	1530	1836	2142
		Noise Criteria	—	17	23	29	34	39	46	53	58
24 x 24	6" Dia.	Airflow, CFM	59	78	98	118	137	157	196	235	275
		Noise Criteria	—	—	—	10	15	19	26	33	38
	6 x 6	Airflow, CFM	75	100	125	150	175	200	250	300	350
		Noise Criteria	—	—	—	12	17	21	28	35	40
	8" Dia.	Airflow, CFM	105	140	175	209	244	279	349	419	489
		Noise Criteria	—	—	—	14	19	23	30	37	42
	8 x 8	Airflow, CFM	133	178	222	267	311	356	444	533	622
		Noise Criteria	—	—	—	15	20	24	31	38	43
	10" Dia.	Airflow, CFM	164	218	273	327	382	436	545	654	764
		Noise Criteria	—	—	10	16	21	25	32	39	44
	10 x 10	Airflow, CFM	208	278	347	417	486	556	694	833	972
		Noise Criteria	—	—	11	17	22	26	33	40	45
	12" Dia.	Airflow, CFM	236	314	393	471	550	628	785	942	1100
		Noise Criteria	—	—	13	19	24	28	35	42	47
	12 x 12	Airflow, CFM	300	400	500	600	700	800	900	1200	1400
		Noise Criteria	—	—	14	20	25	29	36	43	48
	14" Dia.	Airflow, CFM	321	428	535	641	748	855	1069	1283	1497
		Noise Criteria	—	—	15	21	26	30	37	44	49
	14 x 14	Airflow, CFM	408	544	681	817	953	1089	1361	1633	1906
		Noise Criteria	—	10	17	23	28	32	39	46	51
	15 x 15	Airflow, CFM	469	625	781	938	1094	1250	1563	1875	2188
		Noise Criteria	—	12	19	25	30	34	41	48	53
	16" Dia.	Airflow, CFM	419	559	698	838	977	1117	1396	1676	1955
		Noise Criteria	—	10	17	23	28	32	39	46	51
18 x 18	Airflow, CFM	675	900	1125	1350	1575	1800	2250	2700	3150	
	Noise Criteria	—	16	23	29	34	38	45	52	57	
22 x 22	Airflow, CFM	1007	1344	1679	2015	2352	2688	3359	4031	4704	
	Noise Criteria	—	18	25	31	36	40	47	54	59	
48 x 24	46 x 22	Airflow, CFM	2108	2811	3514	4217	4919	5622	7028	8433	9839
		Noise Criteria	11	20	27	34	38	43	50	57	62

Performance Notes:

1. All pressures are in inches w.g..
2. Noise Criteria (NC) values are based upon 10 dB room absorption, re 10⁻¹² watts. Dash (—) in space indicates an Noise Criteria of less than 20.
3. Data derived from tests conducted in accordance with ANSI/ASHRAE Standard 70 – 2006.

PERFORMANCE DATA:

Models 4340R, 4340RA • Surface Mount • Square Neck

Listed Duct Size	Core Area (sq. ft.)	Ak Factor	Core Velocity	300	400	500	600	700	800	900	1000	1200
			Velocity Pressure	.006	.010	.016	.022	.031	.040	.051	.062	.090
			Neg. Static Pressure	.024	.042	.067	.095	.130	.170	.215	.265	.382
6 x 6	0.20	0.20	CFM	60	80	100	120	140	160	180	200	240
			Noise Criteria	—	—	—	15	21	26	32	37	44
8 x 8	0.38	0.36	CFM	114	152	190	228	266	304	342	380	456
			Noise Criteria	—	—	11	18	25	29	35	40	47
10 x 10	0.61	0.56	CFM	183	244	305	366	427	488	549	610	732
			Noise Criteria	—	—	13	20	27	31	37	42	49
12 x 12	0.90	0.80	CFM	270	360	450	540	630	720	810	900	1080
			Noise Criteria	—	—	15	22	28	33	38	44	51
14 x 14	1.24	1.09	CFM	372	496	620	744	868	992	1116	1240	1488
			Noise Criteria	—	—	16	23	29	34	39	45	52
16 x 16	1.64	1.42	CFM	492	656	820	984	1148	1312	1476	1640	1968
			Noise Criteria	—	—	17	24	30	35	40	46	53
18 x 18	2.10	1.80	CFM	630	840	1050	1260	1470	1680	1890	2100	2520
			Noise Criteria	—	—	17	24	30	36	40	46	53
20 x 20	2.61	2.22	CFM	783	1044	1305	1566	1827	2088	2349	2610	3132
			Noise Criteria	—	11	18	25	30	37	41	47	54
22 x 22	3.17	2.69	CFM	951	1268	1585	1902	2219	2536	2853	3170	3804
			Noise Criteria	—	11	18	26	31	37	42	48	55
24 x 24	3.79	3.20	CFM	1137	1516	1895	2274	2653	3032	3411	3790	4548
			Noise Criteria	—	12	19	27	33	38	43	49	56

Performance Notes:

- All pressures are in inches w.g..
- Diffuser tested without damper. Apply the following corrections for addition of opposed blade damper to diffuser:
Neg. Static Pressure Listed Value x 1.10.
Noise Criteria Add 5 dB to listed value.
- Noise Criteria (NC) values are based upon 10 dB room absorption, re 10⁻¹² watts. Dash (—) in space indicates an Noise Criteria of less than 10.
- Data derived from tests conducted in accordance with ANSI/ASHRAE Standard 70 – 2006.
- Core Velocity is in feet per minute.

Airflow Measurements

- Balancing factors are applicable with or without dampers, providing uniform airflow exists into diffuser.
- Take velocity readings at a number of locations on the inlet face (a minimum of 4), while positioning probe as shown above, one inch out from the face.
- Total the various velocity readings and divide by the number of readings taken to arrive at an average inlet velocity (Vk in FPM).
- Calculate the airflow (CFM) by multiplying the average velocity by the appropriate Ak factor.
 Airflow (CFM) = Average velocity (Vk) x Ak.

