

MINIMUM SECURITY GRILLES & REGISTERS

These louvered blade grilles and registers are paired up with a lattice face plate to meet minimum security requirements. They are available for both supply and return air applications with a choice of steel or aluminum construction.

Double Deflection Supply

Stainless Steel - Models SG-67DV, 67DH

Page G17

Steel - Models SG-61DV, SG-61DH

Page G18

Aluminum - Models SG-51DV, SG-51DH

Page G18

Suffix '-O' adds an opposed blade damper.

Single Deflection Supply

Steel - Models SG-61SV, SG-61SH

Page G19

Aluminum - Models SG-51SV, SG-51SH

Page G19

Suffix '-O' adds an opposed blade damper.

Fixed, 45° Deflection

Steel - Models SG-6145H, SG-6145V

Page G20

Aluminum - Models SG-5145H, SG-5145V

Page G20

Suffix '-O' adds an opposed blade damper.

Fixed, 0° Deflection

Steel - Models SG-61FH, SG-61FV

Page G21

Aluminum - Models SG-51FH, SG-51FV

Page G21

Suffix '-O' adds an opposed blade damper.

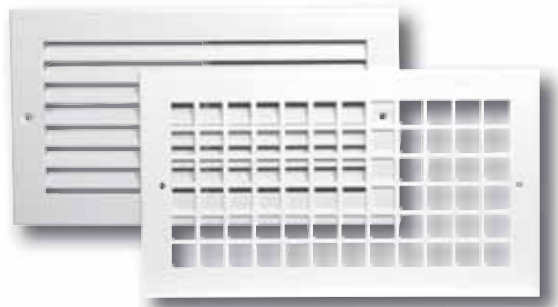
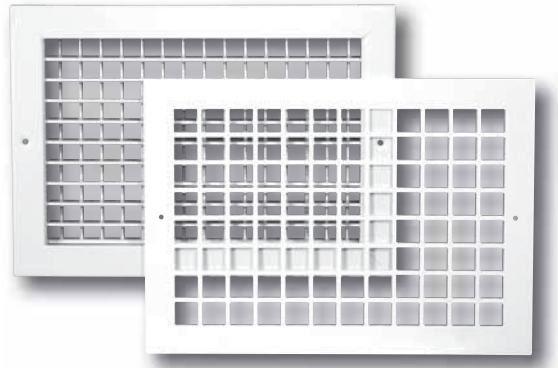

Models SG-67DH, SG-61DH, SG-6145H

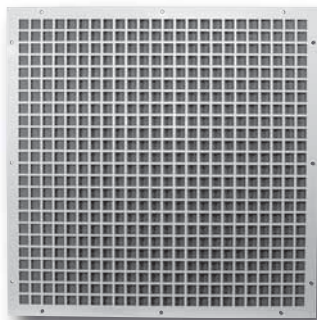

Model SG-LGS-B3

MINIMUM SECURITY LATTICE FACE GRILLES

These lattice face grilles are offered as an economical return air grille for minimum security applications. They are available in heavy gauge steel or heavy gauge aluminum with a selection of hole pattern designs.

Steel Model SG-LGS

Page G22

Aluminum Model SG-LGA

Page G22

OPTIONS & ACCESSORIES

A selection of mounting angles, security bars, opposed blade dampers and directional blades are the enhancements that are offered on the maximum and medium security grilles.

Mounting Angles

Page G24

Masonry Anchor Tabs

Page G24

Security Bars

Page G24

Opposed Blade Dampers

Page G25

Directional Blades

Page G25



Options A and J shown

MINIMUM SECURITY LATTICE FACE GRILLES

- RETURN
- 13/16" (21) SQUARE HOLES ON 1" (25) CENTERS
- 12 GAUGE MATERIAL

Models:

- SG-LGS Steel
- SG-LGA Aluminum

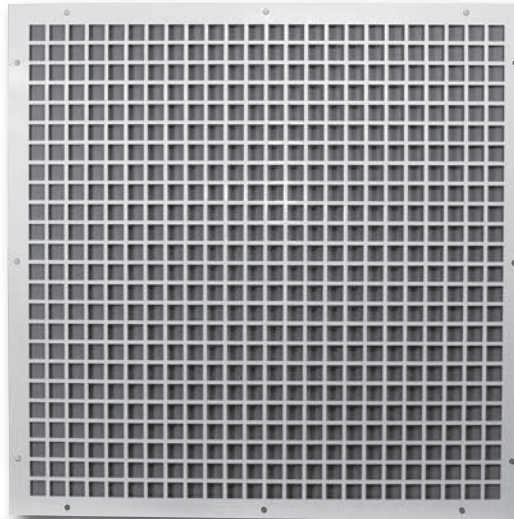

Model SG-LGS-B3

Model Series SG-LG Series Lattice Face Grilles are available as an economical return air grille for minimum security applications.

Model Series SG-LG are available with an optional PF Plaster/Mounting Sub-frame which provides not only a professional finish, but also allows the option of an opposed blade damper mounted inside the neck for air balancing.

STANDARD FEATURES:

- Model Series SG-LG features 13/16" (21) square holes on 1" (25) centers with 3/16" (5) fret bars in 12 gauge (2.75) steel or aluminum construction.
- Screw holes provided in face plate. Tamper proof/security screws by others to suit local requirements.

FINISH OPTIONS:

- Standard finish is AW Appliance White. Other finishes are available.

OPTIONS & ACCESSORIES:

- PF Plaster/Mounting sub-frame.

- Opposed blade damper with screwdriver slot operator, operable from face, available with PF option.
- Other material gauges: 10 gauge or 14 gauge steel or aluminum.
- Other lattice designs. See table.

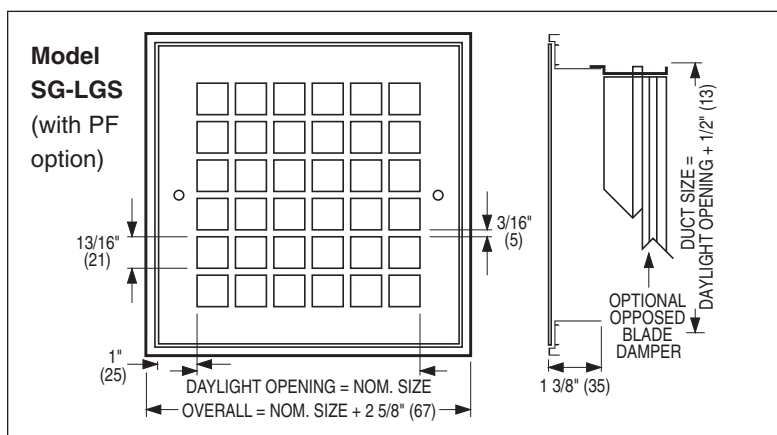
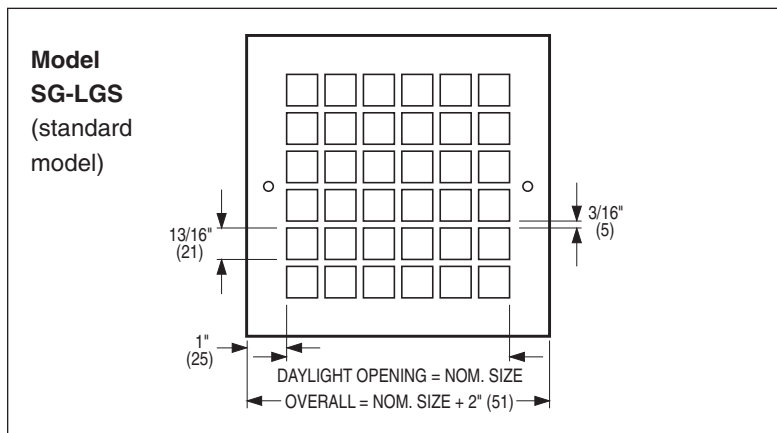

OPTIONAL LATTICE CONFIGURATIONS

Hole Pattern	Code Option		
	10 ga.	12 ga.	14 ga.
3/4" (19) square holes on 1" (25) centers	A1	B1	C1
1/2" (13) square holes on 3/4" (19) centers	A2	B2	C2
13/16" (21) square holes on 1" (25) centers	A3	B3	C3
1" (25) square holes on 1 1/4" (32) centers	A4	B4	C4
2 1/2" x 1/2" (64 x 13) rectangular holes on 2 3/4" x 3/4" (70 x 19) centers	A5	B5	C5

Code option B3 is standard.

SIZING SCHEDULE AND PERFORMANCE DATA:

MODEL SERIES SG-LGS & SG-LGA • LATTICE FACE GRILLES

DAYLIGHT OPENING DIMENSION													
NO. OF HOLES	CODE A1, B1, C1 3/4" SQ.		CODE A2, B2, C2 1/2" SQ.		CODE A3, B3, C3 13/16" SQ.		CODE A4, B4, C4 1" SQ.		NO. OF HOLES	CODE A5, B5, C5 2 1/2" x 1/2"			
										WIDTH		Height	
	in.	mm	in.	mm	in.	mm	in.	mm		in.	mm	in.	mm
6	5 3/4	146	4 1/4	108	5 13/16	148	7 1/4	184	3	6 1/2	165	2	51
8	7 3/4	197	5 3/4	146	7 13/16	198	9 3/4	248	4	8 3/4	222	2 3/4	70
10	9 3/4	248	7 1/4	184	8 13/16	224	12 1/4	311	5	11	279	3 1/2	89
12	11 3/4	298	8 3/4	222	11 13/16	300	14 3/4	375	6	13 1/4	337	4 1/4	108
14	13 3/4	349	10 1/4	260	13 13/16	351	17 1/4	438	7	15 1/2	394	5	127
16	15 3/4	400	11 3/4	298	15 13/16	402	19 3/4	502	8	17 3/4	451	5 3/4	146
18	17 3/4	451	13 1/4	337	17 13/16	452	22 1/4	565	9	20	508	6 1/2	165
20	19 3/4	502	14 3/4	375	19 13/16	503	24 3/4	629	10	22 1/4	565	7 1/4	184
22	21 3/4	552	16 1/4	413	21 13/16	554	27 1/4	692	11	24 1/2	622	8	203
24	23 3/4	603	17 3/4	451	23 13/16	605	29 3/4	756	12	26 3/4	679	8 3/4	222
26	25 3/4	654	19 1/4	489	25 13/16	656	32 1/4	819	13	29	737	9 1/2	241
28	27 3/4	705	20 3/4	527	27 13/16	706	34 3/4	883	14	31 1/4	794	10 1/4	260
30	29 3/4	756	22 1/4	565	29 13/16	757	37 1/4	946	15	33 1/2	851	11	279
32	31 3/4	806	23 3/4	603	31 13/16	808	39 3/4	1010	16	35 3/4	908	11 3/4	298
34	33 3/4	857	25 1/4	641	33 13/16	859	42 1/4	1073	17	38	965	12 1/2	318
36	35 3/4	908	26 3/4	679	35 13/16	910	44 3/4	1137	18	40 1/4	1022	13 1/4	337
38	37 3/4	959	28 1/4	718	37 13/16	960	47 1/4	1200	19	42 1/2	1080	14	356
40	39 3/4	1010	29 3/4	756	39 13/16	1011			20	44 3/4	1137	14 3/4	375
42	41 3/4	1060	31 1/4	794	41 13/16	1062			21	47	1194	15 1/2	394
44	43 3/4	1111	32 3/4	832	43 13/16	1113							
46	45 3/4	1162	34 1/4	870	45 13/16	1164							
48	47 3/4	1213	35 3/4	908	47 13/16	1214							
50			37 1/4	946									
52			38 3/4	984									
54			40 1/4	1022									
56			41 3/4	1060									
58			43 1/4	1099									
60			44 3/4	1137									
62			46 1/4	1175									
64			47 3/4	1213									

SECURITY PRODUCTS

Pressure Loss Through Lattice Grille

Option Code	Core Velocity	300	400	500	600	700	800	900	1000	1200	1400
	Velocity Pressure	.006	.010	.016	.022	.031	.040	.051	.062	.090	.122
A1, B1, C1 (60%)	Negative Static Pressure	.019	.034	.053	.077	.105	.137	.173	.213	.307	.418
A2, B2, C2 (50%)		.032	.057	.089	.128	.174	.228	.288	.356	.512	.697
A3, B3, C3 (70%)		.011	.020	.031	.044	.060	.078	.099	.122	.176	.240
A4, B4, C4 (68%)		.012	.022	.034	.050	.068	.089	.112	.138	.198	.270
A5, B5, C5 (65%)		.015	.027	.042	.061	.083	.108	.137	.167	.243	.331

Performance Notes:

1. All pressure are in inches w.g..
2. Core Velocity is in feet per minute.
3. Core represents daylight opening dimensions.

Options and Accessories

MOUNTING ANGLES:

Option A 1" x 1" x 1/8" (25 x 25 x 3) welded rear angle frame. Shipped loose for field attachment (weld or bolt).

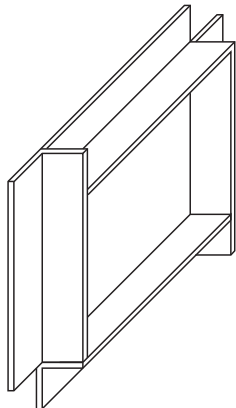

Option B 4 pcs. 1" x 1" x 1/8" (25 x 25 x 3) mounting angles, with holes and bolts. Shipped loose for field attachment.

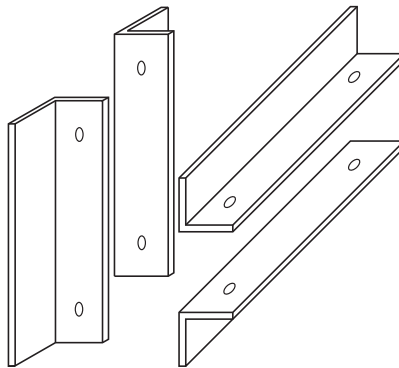

Option C 2 pcs. 1" x 1" x 1/8" (25 x 25 x 3) mounting angles (long dim.). Shipped loose for field attachment (weld or bolt).

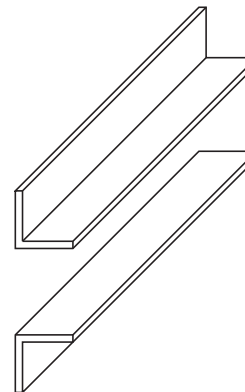

MASONRY ANCHOR TABS AND SECURITY BARS:

Option D 1/2" (13) dia. steel anchor tabs. 3" (76) long for concrete or brick walls. Minimum one per side.

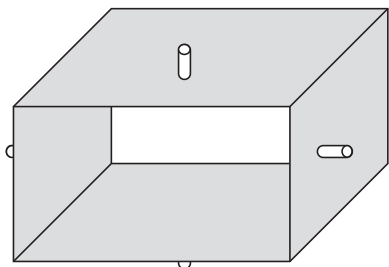

Option E 2 1/2" x 3/8" (64 x 10) flat security bars welded in sleeve, 4" (102) max. on center.

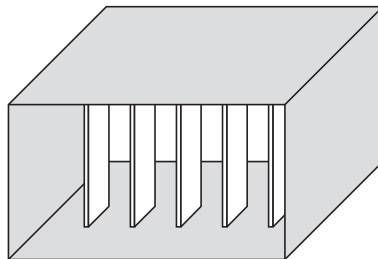

Option F 1/2" (13) dia. round security bars welded in sleeve, 6" (152) max. on center.

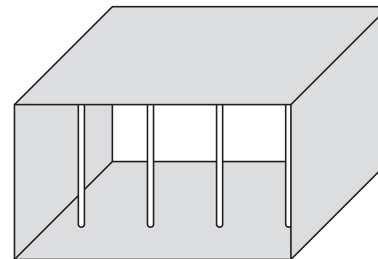

Option G Barrier Grille. 1/2" (13) dia. round security bars, vertical and horizontal, 6" (152) max. on center welded to sleeve and at each cross-point.

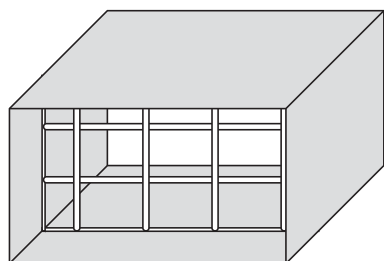

Option H Barrier Grille. 3/4" (19) dia. vertical bars with 2" x 1/4" (51 x 6) horizontal flat bars welded to sleeve and at each cross-point.

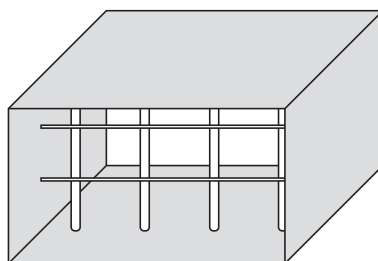

Options and Accessories

OPPOSED BLADE DAMPERS:

Option J Opposed Blade Damper. Face operator (screwdriver slot or lever).

Option K Opposed Blade Damper. Rear operator (screwdriver slot).

DIRECTIONAL BLADES:

Option L Adjustable single deflection horizontal blades on 3/4" (19) centers.

Option M Adjustable single deflection vertical blades on 3/4" (19) centers.

Option N Adjustable double deflection blades on 3/4" (19) centers. Horizontal front blades.

Option P Adjustable double deflection blades on 3/4" (19) centers. Vertical front blades.

Important note for all options and accessories:
 Not all options shown, or certain combinations, are necessarily available on individual security products. Consult the individual model description to determine which options apply.

