

QUALIFICATIONS:

- Meets all the requirements of UL 555 and UL 555S.
- Meets NFPA 80, 90A, 92A, 92B, 101 and 105 as well as IBC and NBC (Canada) Building Code requirements.
- California State Fire Marshal Listing No. 3225-0935:0106.
- City of New York BSA #460-88-SA (Series 1270).
- City of New York MEA #366-03-M (Series 1220).

NOTES:

1. Installation shall be in accordance with the appropriate requirements of the National Fire Protection Association Standard NFPA 90A latest edition.
2. **Damper Sleeve:** Sleeve thickness must be equal to or thicker than the duct connected to it. Sleeve gauge requirements are listed in the SMACNA Fire, Smoke and Radiation Damper Installation Guide for HVAC Systems and in NFPA 90A. If a break-away style duct/sleeve connection is not used, damper sleeves of not less than 16 gauge (1.61) coated steel, may be attached to the duct with screws or other types of mechanical fasteners. The maximum sleeve thickness for such rigid joints is 10 gauge (3.51) for coated steel.
The connecting duct shall not be continuous thru the wall or floor opening but shall terminate at the sleeve. Sleeves shall extend a maximum of 16" (406) on the side intended for use with an actuator.

3. Break-away duct/sleeve connections:

- a. Rectangular ducts must use one or more of the following connections if the gauge is less than the requirement in Note 2 for rigid connections. In addition:

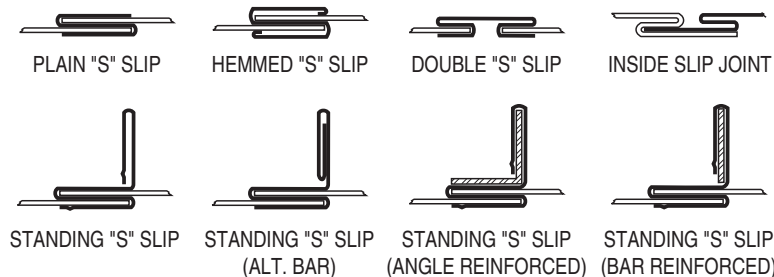

- A maximum of two #10 sheet metal screws on each side and on the bottom, located in the center of the slip pocket and penetrating both sides of the slip pocket may be used.
 - One of the above connections on the top and bottom joints with flat drive slip connections on the side joints may be used for dampers up to 20" (508) in height.
- b.** Round and oval duct may be attached to the round or oval collar which is part of the damper/sleeve in the following manner:



- Duct diameters 22" (559) and smaller must use three #10 sheet metal screws equally spaced around the circumference.
- Note:** When optional sealing of these break-away connections is desired, the duct sealant shall be PA2084T Duct Sealant by Precision or water based DP1010 by Design Polymetrics.

- c. For the use of approved alternative Ductmate or TDC/TDF break-away connections, refer to the supplements noted on this page.
4. **Damper/sleeve attachment:** Damper shall be secured to sleeve with 1/4" (6) long welds, 3/16" (4.76) steel rivets, 1/4" (6.35) dia. bolts and nuts, #8 sheet metal screws, or 3/16" (4.76) dia. buttonloks on both sides at 6" (152) on center and a maximum of 4" (102) from the corners of the damper on all four sides. For field assembled sleeves, the inner dimensions of the sleeve shall be equal to the outer dimensions of the damper. All joints between the damper and the sleeve shall be sealed with Dow-Corning 732 or G.E. RTV108 silicone sealant on one side only.
 5. **Inner Retaining angles** shall be a minimum of 1 1/2" x 1 1/2" x 16 gauge (38 x 38 x 1.61). Secure the retaining angles to the sleeve with 1/2" (12.7) long welds, 1/4" (6.35) dia. bolts and nuts, 3/16" (4.76) dia. steel rivets or #8 sheet metal screws 8" (203) on center and 2" (51) maximum from corner of sleeve on all four sides. The retaining angles must lap the structural opening by 1" (25.4) minimum. Where the sleeve terminates at the wall, 2" (51) wide mounting angle tabs with a 3/4" (19) flange are fastened to the sleeve. Mounting tabs may be installed on top and bottom, or sides, or a combination of both. A steel grille frame with a minimum 1" (25) flange is then fastened to the mounting angle tabs with sheet metal screws.
 6. **Expansion clearance** between the sleeve and the wall opening shall be a minimum of 1/8" per foot (3.18 per 305) of the sleeve in either dimension. The maximum size of the opening shall be 1/8"(3.18) larger in each dimension than the allowable minimum size. For example, a sleeve dimension of 24" x 24" (610 x 610) shall have an opening size of 24 1/4" x 24 1/4" (610 x 610) minimum and 24 3/8" x 24 3/8" (619 x 619) maximum.
 7. **Maximum Damper Size:** 24" x 24" (610 x 610). Minimum size is 8" x 8" (203 x 203). 8" x 6" (203 x 152) for Model 1221G only (maximum width is 18" [457] when height is 6" [152]).
 8. **Actuators Connections and Accessories:** Combination fire/smoke dampers and qualified actuators are tested together by UL and are factory installed to qualify for damper/actuator standard warranties. Factory installed electric actuators are either 24,120 or 230 VAC. All wiring must be in accordance with the appropriate electrical codes and NFPA 70. Factory installed pneumatic actuators are rated at and have a maximum pressure of 25 PSI. The pneumatic actuator shall be connected to the air supply thru metallic tubing. A short silicone tubing pigtail is acceptable.
- ERL (Electric Resettable Link):** Dampers are supplied with an electric thermostat-type temperature responsive device as standard. Refer to Figure 1 for wiring of the ERL. If dampers are ordered with a pneumatic actuator and ERL, an EP switch is required with an appropriate electric power circuit to allow the ERL to control the pneumatic actuator.
- When DTO Dual Temperature Override Sensors (MLS-400) or MLS-300 position indicators are used, refer to the installation and wiring instructions for these units. Documents IOM-DTO and IOM-MLS3 (H or N) respectively.

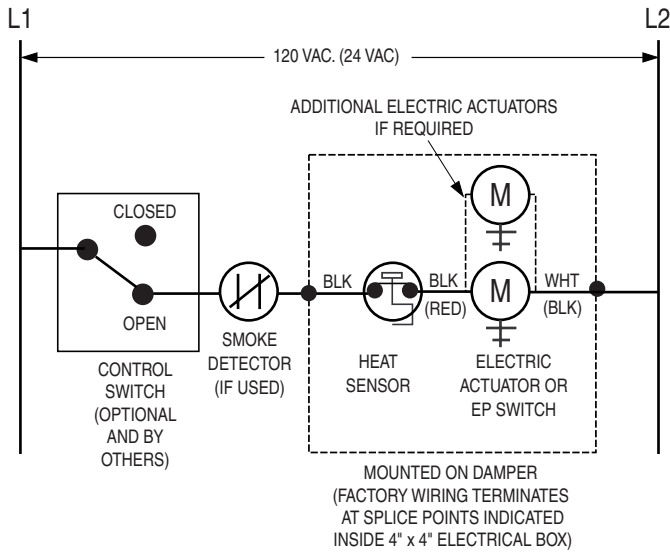

Figure 1. ERL Wiring

IMPORTANT:

- DO NOT CAST DAMPER IN PLACE.
- DO NOT FASTEN RETAINING ANGLES OR DAMPER DIRECTLY TO WALL OR FLOOR.
- DO NOT INSTALL DAMPER OUT OF SQUARE OR OUT OF FLAT.
- VERTICAL MOUNTING SHOWN ON MASONRY WALL.
- FOR INSTALLATION IN DRYWALL FRAMING, SEE DOC. FDSWSFINST.
- HORIZONTAL MOUNTING SIMILAR FOR MASONRY WALL.

REFER TO THE APPROPRIATE NAILOR INSTALLATION INSTRUCTION SUPPLEMENTS FOR ADDITIONAL INFORMATION OR SPECIAL REQUIREMENTS:

MLS-300 (Honeywell) POSITION INDICATOR	MLS3H
MLS-300 (Nailor) POSITION INDICATOR	MLS3N
DTO DUAL TEMPERATURE OVERRIDE SENSOR (MLS-400)	DTO
ERL ELECTRIC RESETTABLE LINK	ERL
STEEL AND WOOD STUD FRAMING	FDSWSFINST
CAVITY SHAFT WALL PARTITIONS	FDCSWINST
FLANGED TYPE ALTERNATE BREAKAWAY CONNECTIONS	FDFABCINST
TDC/TDF FLANGED DUCT CONNECTION	FDTDCFINST
QUICK-SET RETAINING ANGLES	FDQSRA

Dimensions are in inches (mm).

Page 2 of 2



Houston, Texas
Tel: 281-590-1172
Fax: 281-590-3086

Las Vegas, Nevada
Tel: 702-648-5400
Fax: 702-638-0400

Toronto, Canada
Tel: 416-744-3300
Fax: 416-744-3360

Calgary, Canada
Tel: 403-279-8619
Fax: 403-279-5035