



**FACTORY MOUNTED DUCT SMOKE DETECTOR
LOW FLOW (100 TO 4000 FPM AIR VELOCITY)
FOR USE WITH 1200 SERIES SMOKE AND COMBINATION
FIRE/SMOKE DAMPERS
MODEL: DSD-LF**

QUALIFICATIONS:

The following qualifications apply to the smoke detector only. There is no separate UL product category for factory-mounted detector/damper combination. Refer to individual damper specification drawing for damper qualifications. Consult the local authority having jurisdiction before installation to ensure local code compliance.

- UL 268A Listed Smoke-automatic Detectors, Category UROX (File # S911).
- Meets the requirements of NFPA 72, 90A, 92 and 101.
- City of New York. MEA No. 29-01-E.
- California State Fire Marshal Listing No. 7272-1653:0207.
- Factory Mutual Approved.

APPLICATION:

Nailor model DSD-LF duct smoke detector (low-flow) can be utilized with Nailor UL 555S Classified smoke or combination fire/smoke dampers to detect the presence of smoke within HVAC ductwork and close the damper to prevent the smoke from spreading. As most fatalities resulting from fires can be attributed to the effects of toxic smoke, detecting and controlling the smoke from spreading within the HVAC system is vital to preventing injury as well as limiting property damage, including damage to the HVAC system itself. Refer to NFPA Standards 72, 90A and 92 to determine when and where duct smoke detectors are required.

The DSD-NF detector can be factory installed to side of sleeve on Nailor Model Series 1210, 1260, 1280, 1220 and 1270.

A minimum airflow velocity of 100 fpm (0.5 m/s) is required for Model DSD-LF.

OPERATION:

Upon detection of smoke, the smoke detector causes the damper to close by cutting off power to the actuator. The actuator return spring forces the damper closed. The detector can be reset only by a momentary power interruption. The standard model DSD-LF detector and smoke damper combination is designed simply to close the damper upon detection of smoke. For applications requiring the detector to be wired into a firefighters' smoke-control station (FSCS), contact Nailor.

DSD-LF STANDARD SPECIFICATION:

Model: System Sensor D4120.

Sensor Type: Photoelectric.

Dimensions: (Rectangular) 14.38" (365) Length, 5" (127) Width, 2.5" (64) Depth.

Weight: 2.5 lbs. (1.14 kg.).

Airflow Velocity Range: 100 to 4000 fpm (0.5 to 20.3 m/s).

Operating Temperature Range: -4°F to 158°F (-20°C to 70°C).

Operating Humidity Range: 0% to 95% Relative Humidity Non-Condensing.

Voltage: 24 VAC/DC or 120 VAC.

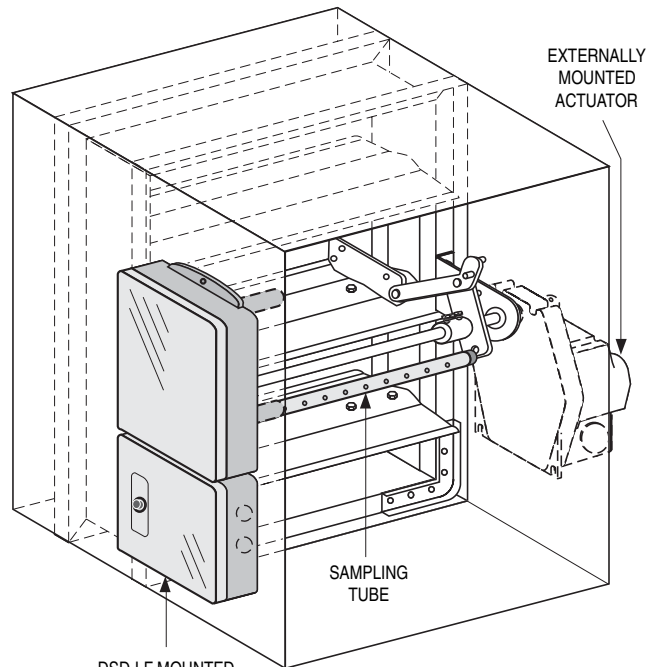

NOTES:

1. Smoke detector is factory mounted externally on left side of sleeve (opposite side of sleeve to the actuator) and will be mounted horizontally on dampers under 20" (508) in height and mounted vertically on dampers 20" (508) in height and over. See orientation details below.
2. Factory mounted smoke detectors will be factory wired to actuator(s) (or E.P. switch) and heat sensor(s), as applicable, into a 4" x 4" (102 x 102) common junction box in order to provide a single point wiring connection in the field.

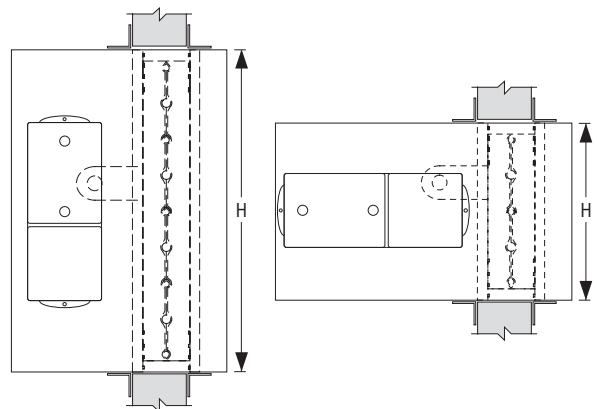

Height ≥ 20" (508)

Height < 20" (508)

Dimensions are in inches (mm).

SCHEDULE TYPE:					
PROJECT:					
ENGINEER:		DATE	B SERIES	SUPERSEDES	DRAWING NO.
CONTRACTOR:		9 - 4 - 13	1200	NEW	DSD-LF