



**DYNAMIC STAINLESS STEEL MULTI-BLADE FIRE DAMPER**  
 FOR USE IN DYNAMIC OR STATIC SYSTEMS  
 HIGH PERFORMANCE • AIRFOIL BLADE  
 3 HR. LABEL • VERTICAL MOUNT  
 ROUND DUCT CONNECTION  
**MODEL: D1203SS-3 (TYPE C SLEEVE ENCLOSURE)**



**QUALIFICATIONS:**

- **UL 555 & CAN/ULC-S112 CLASSIFIED DYNAMIC FIRE DAMPER 3 hr. Label (File # R9492).**
- **Meets NFPA 80, 90A and 101 as well as IBC and NBC (Canada) Building Code requirements.**
- **California State Fire Marshal Listing No. 03225-0935:0101.**
- **City of New York. MEA# 366-03-M.**
- **Maximum velocity 2000 fpm @ 4" w.g. (10 m/s @ 1 kPa).**

The D1200SS-3 Series dampers are ideal for high humidity, mildly corrosive or, with optional Type 316 construction, more severe environment applications where building codes require a fire damper for the protection of ductwork penetrations in walls that have a fire resistance rating of up to 4 hours.

The D1200SS-3 Series is classified for use in dynamic "fans on" systems where the HVAC system remains operative in the event of a fire alarm. Damper closure under airflow is assured.

The D1200SS-3 Series has been especially designed and tested to provide premium performance. Airfoil blade design and elimination of blade sills, top and bottom, provide a low pressure drop design.

The D1200SS-3 Series features the industry proven over-center knee-lock design with high torque spring/fusible link closure.

Unique, inter-locking double skin blade design provides flame and smoke seal under fire conditions.

The D1203SS-3 is supplied as standard with an internal crank arm and locking screw which holds the damper in the fully open position, but may also be used for system balancing if required.

**STANDARD SPECIFICATION:**

- Frame:** 5" x 7/8" x 16 ga. (127 x 22 x 1.6) stainless steel hat channel.
- Blades:** 14 ga. (2.0) equivalent stainless steel formed airfoil on 5 1/2" (140) centers. Opposed blade action.
- Linkage:** Concealed in frame. 12 ga. (2.7) stainless steel.
- Bearings:** 1/2" (13) dia. sintered stainless steel.
- Axles:** 1/2" (13) dia. stainless steel double bolted to blades.
- Jackshaft:** 1/2" (13) dia. stainless steel. CCW rotation to open. Internal locking quadrant is factory installed.
- Fusible Link:** 165°F (74°C) standard.
- Min. Duct Size:** Vertical mount only: 4" (102) diameter. (Overall damper size is 8" x 8" [203 x 203] min.).
- Max. Duct Size:** Single Section  
Vertical mount only: 34" (864) diameter.  
Multiple Section Assembly  
Vertical mount only: 58" (1473) diameter (Individual sections not to exceed 28" [711] dia. duct size).

**BASE MODEL SELECTION:**

- D1203SS-3** Standard factory sleeve 16" long x 20 ga. (406 x 1.0).
- D1203SS-3** Non-standard sleeve. Specify \_\_\_\_\_ length \_\_\_\_ ga. Available up to 36" (914) dependent upon wall thickness and 10 through 20 ga. (3.5 through 1.0).

**CONSTRUCTION TYPE:**

- 304** Type 304 Stainless Steel construction (Standard)
- 316** Type 316 Stainless Steel construction (Optional)

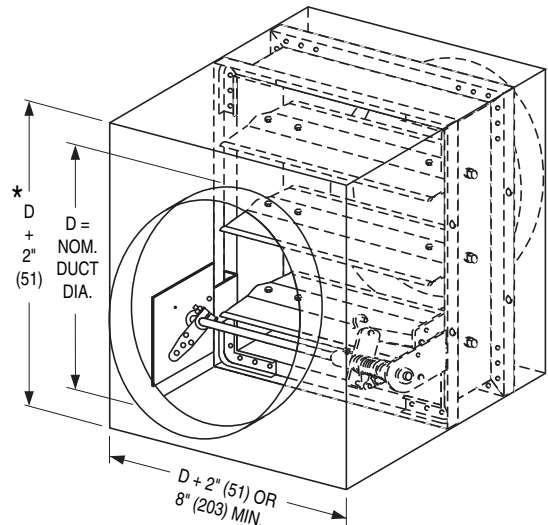

\* or 8" (203) min.

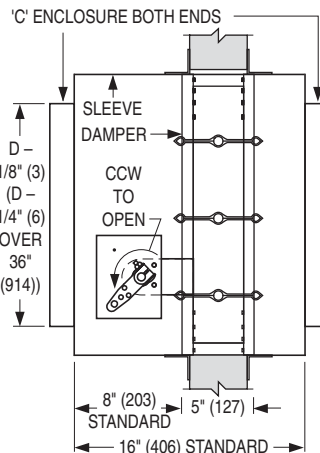

Wall Thickness	Minimum Sleeve Length
4 (102)	16 (406)
8 (203)	20 (508)
12 (305)	24 (610)
16 (406)	28 (711)

**OPTIONS:**

- MLS-300** Position indicator switch pack
  - JSS** Flexible stainless steel jamb seals
  - QS1** Quick-set retaining angle (one side)
  - QS2** Quick-set retaining angles (two sides)
- Note:** QS1 and QS2 are galvanized steel.
- Special features** \_\_\_\_\_

For installation instructions, see IOM-MBSSFDINST.

Dimensions are in inches (mm).

<b>SCHEDULE TYPE:</b>				
<b>PROJECT:</b>				
<b>ENGINEER:</b>	<b>DATE</b>	<b>B SERIES</b>	<b>SUPERSEDES</b>	<b>DRAWING NO.</b>
<b>CONTRACTOR:</b>	4 - 3 - 13	1200	1 - 1 - 12	D1200SS-3-3