



DYNAMIC STAINLESS STEEL MULTI-BLADE FIRE DAMPER
 FOR USE IN DYNAMIC OR STATIC SYSTEMS
 HIGH PERFORMANCE • AIRFOIL BLADE
 1 1/2 HR. LABEL • VERTICAL MOUNT
MODELS: D1200SS AND D1201SS (TYPE A)



QUALIFICATIONS:

- **UL 555 & CANULC-S112 CLASSIFIED DYNAMIC FIRE DAMPER 1 1/2 hr. Label (File # R9492).**
- **Meets NFPA 80, 90A and 101 as well as IBC and NBC (Canada) Building Code requirements.**
- **California State Fire Marshal Listing No. 03225-0935:0101.**
- **City of New York. MEA# 366-03-M.**
- **Maximum velocity 2000 fpm @ 4" w.g. (10 m/s @ 1 kPa).**

The D1200SS Series dampers are ideal for high humidity or mildly corrosive applications where building codes require a fire damper for the protection of ductwork penetrations in walls that have a fire resistance rating of up to 2 hours.

The D1200SS Series is classified for use in dynamic "fans on" systems where the HVAC system remains operative in the event of a fire alarm. Damper closure under airflow is assured.

The D1200SS Series has been especially designed and tested to provide premium performance. Airfoil blade design and elimination of blade sills, top and bottom, provide a low pressure drop design.

The D1200SS Series features the industry proven over-center knee-lock design with high torque spring/fusible link closure.

Unique, inter-locking double skin blade design provides flame and smoke seal under fire conditions.

The D1200SS is supplied as standard with an internal crank arm and locking screw which holds the damper in the fully open position, but may also be used for system balancing if required.

The D1200SS is available in either Type 304 or 316 stainless steel.

STANDARD SPECIFICATION:

- Frame:** 5" x 7/8" x 16 ga. (127 x 22 x 1.6) stainless steel hat channel.
- Blades:** 14 ga. (2.0) equivalent stainless steel formed airfoil on 5 1/2" (140) centers. Opposed blade action.
- Linkage:** Concealed in frame. 12 ga. (2.7) stainless steel.
- Bearings:** 1/2" (13) dia. sintered stainless steel.
- Axles:** 1/2" (13) dia. stainless steel double bolted to blades.
- Jackshaft:** 1/2" (13) dia. stainless steel. CCW rotation to open. Internal locking quadrant is factory installed.
- Fusible Link:** 165°F (74°C) standard.
- Minimum Size:** Vertical mount only: 8" x 8" (203 x 203).
- Maximum Size:** Single Section
Vertical mount only: 36" x 48" (914 x 1219).
Multiple Section Assembly
Vertical mount only: 72" x 96" (1829 x 2438) or
144" x 48" (3658 x 1219).

Dampers with duct heights less than 8" require a Type 'B' sleeve enclosure (Model D1202SS). Units less than 8" (203) in width only, or in both width and height, require a Type 'C' enclosure (Model D1203SS).

BASE MODEL SELECTION:

- D1200SS** Less sleeve.
- D1201SS** Standard factory sleeve 16" long x 20 ga. (406 x 1.0) (18 ga. [1.3] for dampers over 84" [2134] in width).
- D1201SS** Non-standard sleeve. Specify _____ length _____ ga. Available up to 36" (914) dependent upon wall thickness and 10 through 20 ga. (3.5 through 1.0).

CONSTRUCTION TYPE:

- 304** Type 304 Stainless Steel construction (Standard)
- 316** Type 316 Stainless Steel construction (Optional)

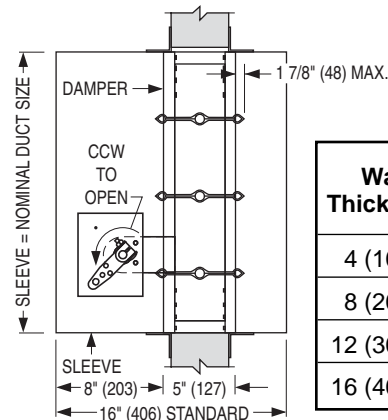
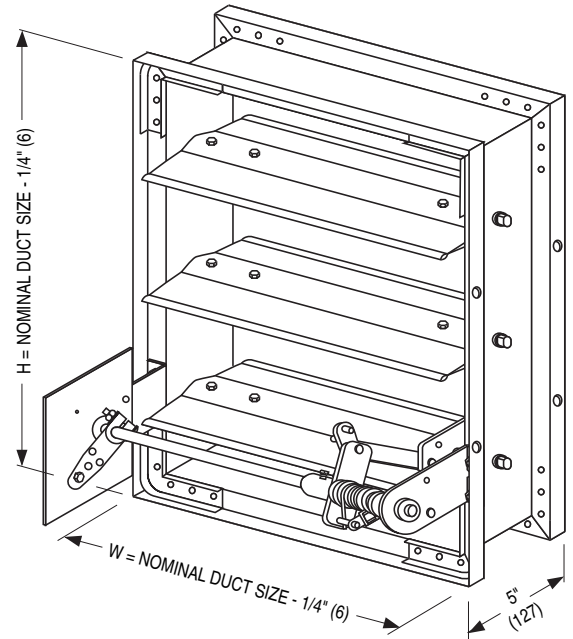

Wall Thickness	Minimum Sleeve Length
4 (102)	16 (406)
8 (203)	20 (508)
12 (305)	24 (610)
16 (406)	28 (711)

OPTIONS:

- SMP** Side mounting plate
 - MLS-300** Position indicator switch pack
 - JSS** Flexible stainless steel jamb seals
 - QS1** Quick-set retaining angle (one side)
 - QS2** Quick-set retaining angles (two sides)
- Note:** QS1 and QS2 are galvanized steel.
- Special features** _____

For installation instructions, see IOM-MBSSFDINST.

Dimensions are in inches (mm).

SCHEDULE TYPE:				
PROJECT:				
ENGINEER:	DATE	B SERIES	SUPERSEDES	DRAWING NO.
CONTRACTOR:	4 - 3 - 13	1200	1 - 1 - 12	D1200SS-1