



AIR BALANCING DEVICES

DAMPER WITH EQUALIZING GRID FOR SQUARE AND RECTANGULAR NECKS

MODELS: DEGS AND DEGL

DESCRIPTION:

1. Material: Corrosion-resistant steel.
2. The Nailor Models DEGS and DEGL are duct mounted combination dampers with grids for use in square and rectangular ducts.
3. The Nailor Models DEGS and DEGL perform as volume extractors with dampening to near shut-off and equalizes the airflow into the duct drop and diffuser neck, also providing directional control. The individually adjustable vanes are friction pivoted to hold the desired setting. The hinged damper may be adjusted to any angle using the adjustment rods, which are then secured to the inside of the duct drop with a sheet metal screw through a tubing clamp.
4. Model DEGS blades are parallel to the short dimension 'H'. Model DEGL blades are parallel to the long dimension 'W'.
5. 'A' Dimension with Damper at 45°.
 - DEGL = $H \times .70$
 - DEGS = $W \times .70$
6. Minimum Size: 6" x 6" (152 x 152).
Maximum Size: 30" x 24" (762 x 610).
Fractional Sizing is not available.

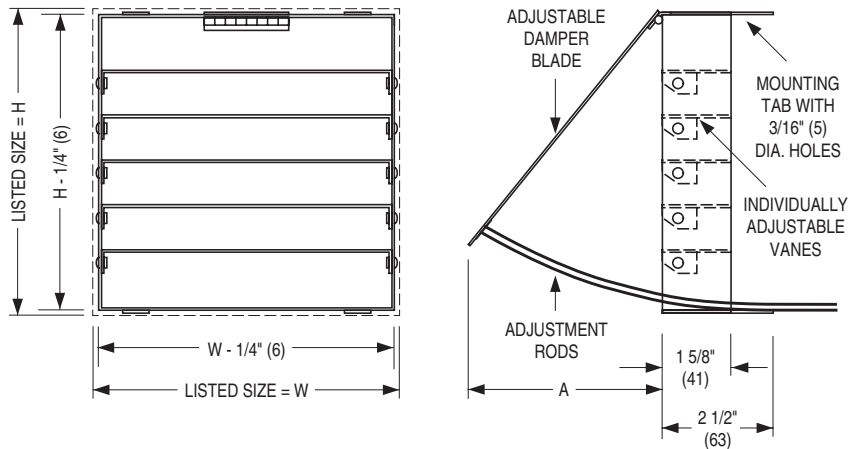

DETAIL:

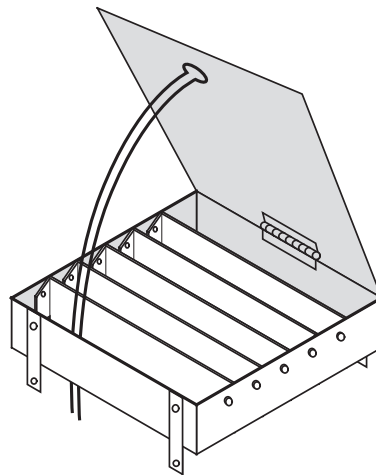

TYPICAL INSTALLATION:

1. Shipped loose for field installation. Recommended method of installation is flush with the take-off collar with the vanes perpendicular to the airflow. The damper opens upstream to divert the air.

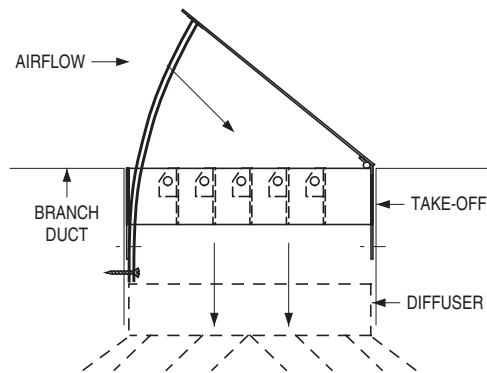

SCHEDULE TYPE:

PROJECT:

ENGINEER:

CONTRACTOR:

Dimensions are in inches (mm).

DATE

B SERIES

SUPERSEDES

DRAWING NO.

3 - 31 - 21

ACC.DIF.

25 - 8 - 99RR

ACC.DEGS/L