

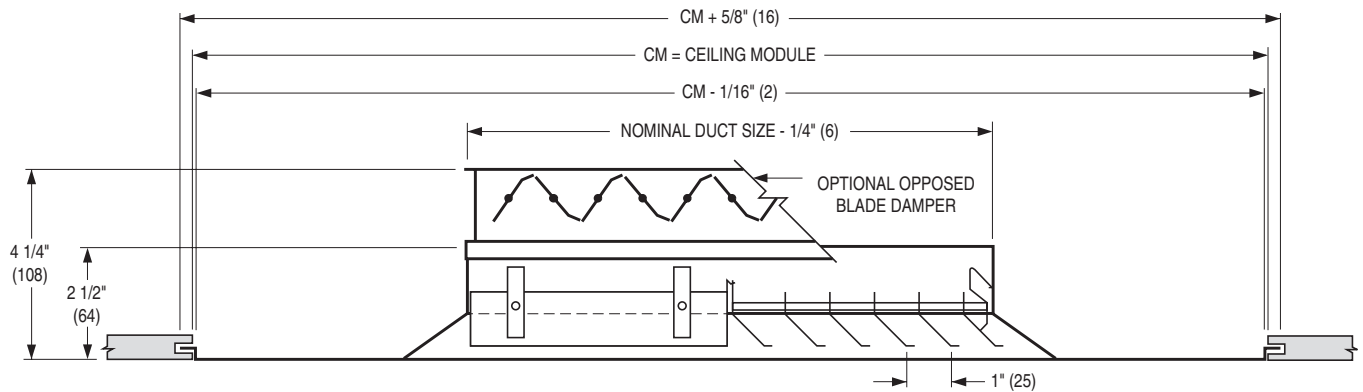

MODULAR CORE CEILING DIFFUSER
 1, 2, 3 OR 4-WAY ADJUSTABLE DISCHARGE
 PATTERN • SQUARE NECK • STEEL
 MODELS: 7500 AND 7500-O TYPE SP

TYPE SP SPLINE



If the ceiling module is more than 3" (76) larger than the neck size of the diffuser, a steel, module sized extended panel will be added. Spline type diffuser for one-directional exposed T-bar Lay-in grid or for concealed T-bar grid. (Splines on two opposite sides. Steel lift brackets on the other two sides).

Ceiling Module CM			Available Duct Sizes		
Imperial Modules		Metric Modules			
Imperial Units (inches)	SI Units (mm)	SI Units (mm)			
12 x 12	305 x 305	300 x 300	6 x 6 (152 x 152)	8 x 8 (203 x 203)	9 x 9 (229 x 229)
24 x 12	610 x 305	600 x 300			
24 x 24	610 x 610	600 x 600	6 x 6 (152 x 152)	10 x 10 (254 x 254)	15 x 15 (381 x 381)
			8 x 8 (203 x 203)	12 x 12 (305 x 305)	16 x 16 (406 x 406)
			9 x 9 (229 x 229)	14 x 14 (356 x 356)	18 x 18 (457 x 457)

DESCRIPTION:

1. Material: Heavy ga. corrosion-resistant steel.
2. Model 7500 is a versatile ceiling diffuser. It consists of four spring loaded modular cores that may be simply adjusted by rotating each module after installation to provide a 1, 2, 3 or 4-way blow pattern. A tight horizontal air pattern from maximum to minimum flow makes it ideal for VAV applications.
3. Standard finish is AW Appliance White.

OPTIONS:

SQUARE NECK

- Steel opposed blade damper - Model 7500-O

ROUND NECK

- SQR Square to round transition collar
 SQR-O Square to round transition collar for use over opposed blade damper. ___ round neck size (inches)
 4275 Radial damper
 4250 Radial sliding blade damper
 4675 Butterfly damper

OPTIONAL FINISH:

- SP Special. Specify _____.

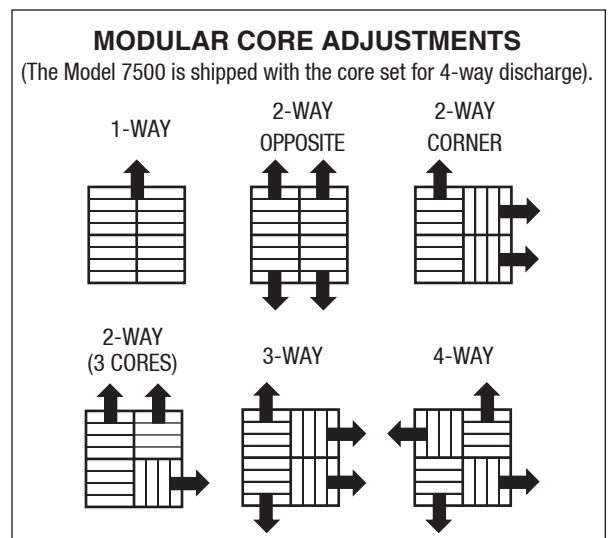

SCHEDULE TYPE:	Dimensions are in inches (mm).			
PROJECT:				
ENGINEER:	DATE	B SERIES	SUPERSEDES	DRAWING NO.
CONTRACTOR:	9 - 8 - 21	7500	3 - 1 - 16	7500-3A