

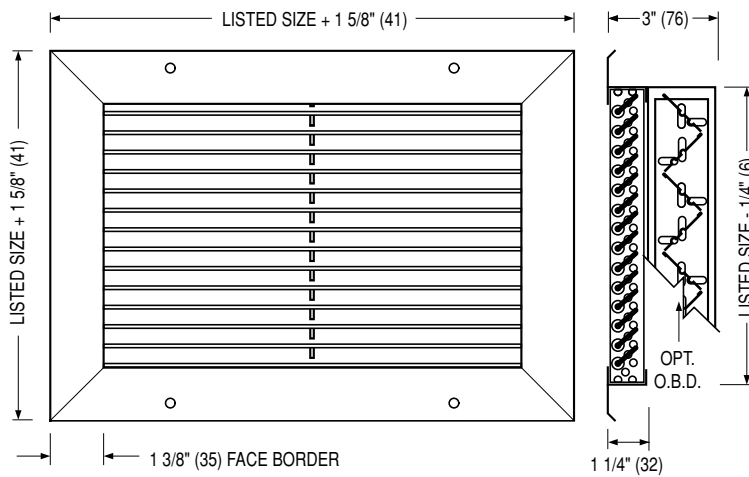

HEAVY DUTY STAINLESS STEEL RETURN GRILLES & REGISTERS • FIXED BLADE MODELS: 6755H-HD(-O) AND 6755V-HD(-O) TYPE S



MODEL 6755H-HD
Single Deflection Grille
Fixed 45° Horizontal Blades

MODEL 6755H-HD-O
Single Deflection Register
Fixed 45° Horizontal Blades
(Includes O. B. Damper)

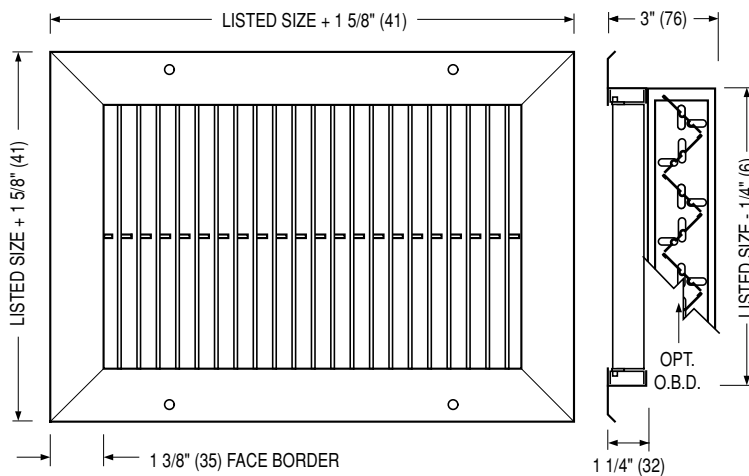

MODEL 6755V-HD
Single Deflection Grille
Fixed 45° Vertical Blades

MODEL 6755V-HD-O
Single Deflection Register
Fixed 45° Vertical Blades
(Includes O. B. Damper)

DESCRIPTION:

1. Construction: Type 304 stainless steel welded and reinforced frame features hairline mitered corners. Streamlined shaped grille blades on 1/2" (13) centers are fixed at 45 degrees to match and compliment the supply grilles and registers. Blades are reinforced by an additional support mullion on maximum 8" (203) centers.
2. Optional roll-formed Type 304 stainless steel opposed blade damper.
3. Minimum size is 4" x 4" (102 x 102).
Maximum size is 60" x 48" (1524 x 1219).
4. Type S Surface mount standard frame has a 1 3/8" (35) face border.
5. Standard fastening is Type A countersunk screw holes.
6. Standard finish is #4 Brushed Satin Polished.

OPTIONS:

1. Construction:
 - 316 Type 316 stainless steel.
2. Finish:
 - AW Appliance White.
 - SP Special _____ .
3. PFS Stainless Steel Plaster frame
4. Other _____ .

SCHEDULE TYPE:

PROJECT:

ENGINEER:

CONTRACTOR:

Dimensions are in inches (mm).

DATE

B SERIES

SUPERSEDES

DRAWING NO.

5 - 11 - 15

6700

9 - 22 - 11

6700-HD-1