

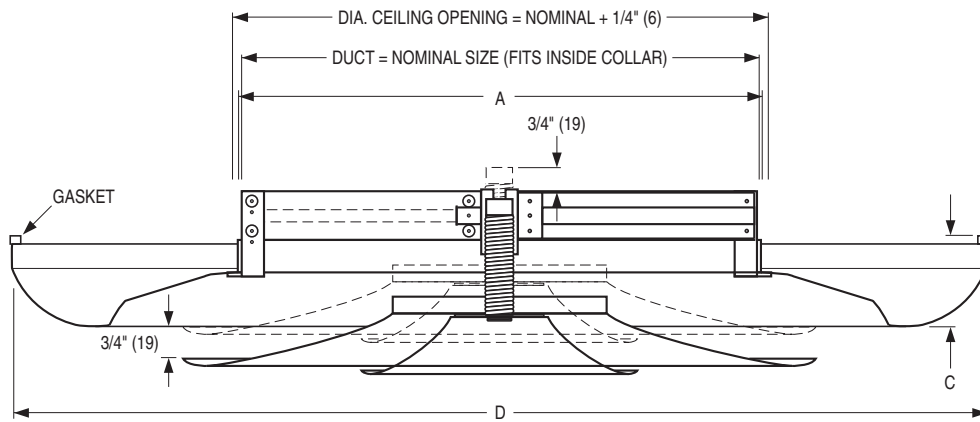

ROUND CEILING DIFFUSERS
SPUN ALUMINUM CONSTRUCTION
MODELS: 6300 AND 6300R



Dimensional Data

Listed Size	Imperial Units (inches)			Metric Units (mm)		
	A	C	D	A	C	D
6	6 1/8	3/4	12 1/8	156	19	308
8	8 1/8	1	15 1/2	206	25	394
10	10 1/8	1 1/4	18 7/8	257	32	479
12	12 1/8	1 3/8	22 1/4	308	35	565
14	14 1/8	1 9/16	25 5/8	359	40	651
16	16 1/8	1 3/4	29	410	44	737
18	18 1/8	1 15/16	32 3/8	460	49	822
20	20 1/8	2 1/8	35 3/4	511	54	908
24	24 1/8	2 1/2	42 1/2	613	64	1080

Notes:

- 1/4" (6) oversize duct fits outside collar, if desired.
- A = Inside diameter of diffuser neck.
- C = Projection of diffuser outer cone below ceiling.
- D = Overall diameter of diffuser.

DESCRIPTION:

1. Material: Spun aluminum construction.
2. The Nailor 6300 Series Round Ceiling Diffusers are available in a comprehensive range of sizes with a capacity ranging from 50 to 5000 cfm (24 – 2360 l/s). They are suitable for both cooling and heating applications. They offer the same balanced appearance where different sizes are used in the same zone. They feature a 360 degree air diffusion pattern and provide excellent performance in Variable Air Volume Systems.
3. Designed for both heating and cooling applications.
4. Excellent for variable air volume applications.
5. Standard finish: AW Appliance White.

ACCESSORIES (OPTIONAL):

- AL Aluminum finish.
- 4275 Radial Opposed Blade Damper (round).
- EGR Equalizing Grid.
- SC Safety Chain.
- SP Special finish _____ .

Model 6300 – Two Position Adjustment

Model 6300 is fixed in either an "UP" or a "DOWN" position through a system of clips to stationary positions. The core is easily adjusted. An optional round opposed blade damper is screwdriver-operated through the face of the unit. The **Model 6300** has a 2-position core to guide vertical or horizontal projection of the air.

Model 6300R – Continuous Rotary Adjustment

Model 6300R provides 3/4" (19) adjustability through utilization of a threaded mechanism. The "UP" position of the core provides vertical throw and the "DOWN" position provides horizontal throw. The core is easily adjusted. An optional round opposed blade damper is screwdriver-operated through the face of the unit. The **Model 6300R** has a fully adjustable core to guide vertical or horizontal projection of the air.

SCHEDULE TYPE:

PROJECT:

ENGINEER:

CONTRACTOR:

Dimensions are in inches (mm).

DATE

B SERIES

SUPERSEDES

DRAWING NO.

3 - 10 - 16

6300

11 - 5 - 07

6300-1