

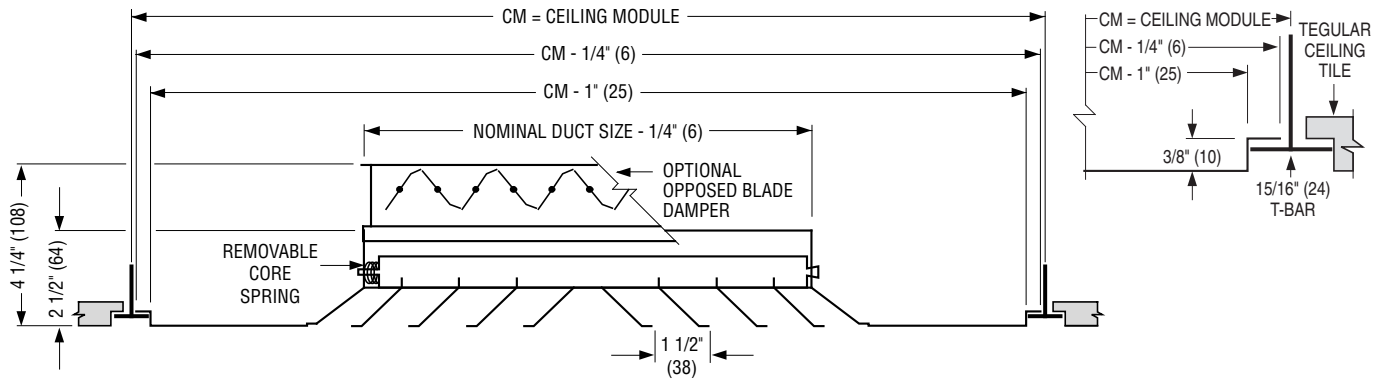

PATTERN CEILING DIFFUSERS
ALUMINUM • SQUARE, RECTANGULAR OR
ROUND NECK
MODELS: 6200 AND 6200-O TYPE TL

TYPE TL TEGULAR LAY-IN



Minimum duct size: 6 x 6 (152 x 152).
 Maximum duct size: see table.
 Available in 3" (76) increments only.

IMPERIAL MODULES		METRIC MODULES		METRIC MODULES	
Imperial Units (in.)	Maximum Duct Size	Metric Units (mm)	Maximum Duct Size	Metric Units (mm)	Maximum Duct Size
CM		CM		CM	
12 x 12	6 x 6	305 x 305	152 x 152	300 x 300	152 x 152
24 x 12	18 x 6	610 x 305	457 x 152	600 x 300	457 x 152
24 x 24	18 x 18	610 x 610	457 x 457	600 x 600	457 x 457

CORE STYLE SELECTION

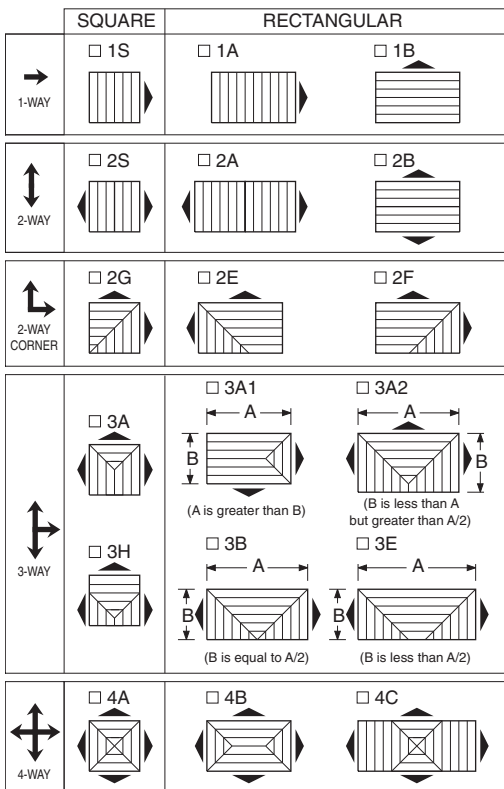

Patterns are shown in plan view (looking down into inlet).

DESCRIPTION:

1. Material: Aluminum. Extended panel where required is corrosion-resistant coated steel.
2. Model 6200 is a high capacity ceiling diffuser available in 1, 2, 3 or 4-way blow patterns to provide a tight horizontal airflow pattern from maximum to minimum airflow. Ideal for VAV applications.
The diffuser is supplied in a module sized extended panel which drops the diffuser face below the T-bar so that it is flush with the tegular ceiling panels.
3. Spring-loaded removable core.
4. Standard finish is AW Appliance White.

OPTIONS:

- PLA Aluminum Extended Panel.
- Steel opposed blade damper. Model 6200-O.
- Aluminum opposed blade damper. Model 6200-OA.

ROUND NECK

- SR Square to round transition collar
- SR-O Square to round transition collar for use over O.B.D.
- 4275 Radial Opposed Blade Damper (round)
- 4250 Radial Sliding Blade Damper (round)
- 4675 Butterfly Damper (round)

EXTERNAL INSULATION

- EX External Foil-Back Insulation, installed -R-4.2.
- MIB Molded Insulation Blanket, -R-6.0. ('MIB' available for Frame Types L, TL and F with a 24 x 24 CM only, 15 x 15 max. neck size and a 'SR' square-to-round transition collar).

OPTIONAL FINISH:

- SP Special. Specify _____.

SCHEDULE TYPE:		Dimensions are in inches (mm).			
PROJECT:					
ENGINEER:	DATE	B SERIES	SUPERSEDES	DRAWING NO.	
CONTRACTOR:	1 - 16 - 17	6200	5 - 11 - 15	6200-5	