

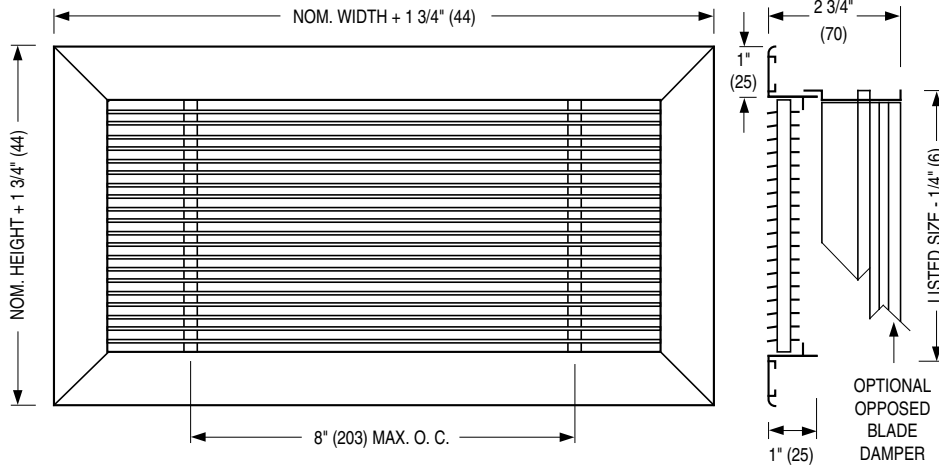

REVERSIBLE CORE GRILLES & REGISTERS
SUPPLY OR RETURN • FIXED NARROW BLADES
EXTRUDED ALUMINUM
MODELS: 51RC(-O) AND 51RCD(-O)



- MODEL 51RC**
Reversible Core Grille
- MODEL 51RC-O**
Reversible Core Register
(Includes O. B. Damper)

Reversible core provides 4 different vertical deflections:

- 15° UP →
- 15° DOWN →
- 5° UP →
- 5° DOWN →

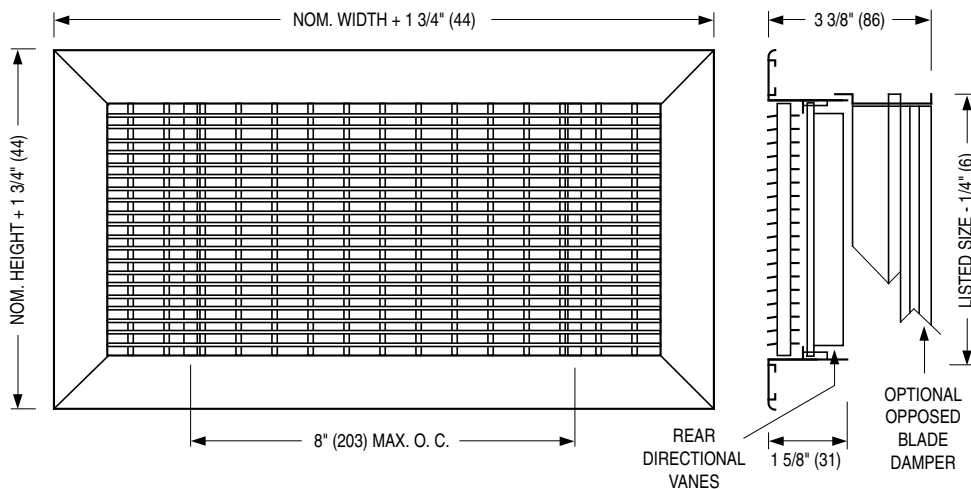

- MODEL 51RCD**
Reversible Core Grille with
Rear Directional Vanes
- MODEL 51RCD-O**
Reversible Core Register with
Rear Directional Vanes
(Includes O. B. Damper)

DESCRIPTION:

Reversible core 'linear style' grilles and registers combine rugged aluminum construction, pleasing architectural design and flexible air pattern versatility.

The blade core is removable and may be rotated or reversed to achieve any one of four air deflection patterns.

For additional air pattern control in supply applications, these grilles are available with optional rear deflection vanes which are friction pivoted and adjustable in order to provide horizontal spread of the air pattern from 0° to 45°.

CONSTRUCTION:

1. Extruded aluminum frame is mechanically interlocked for strength with reinforced hairline mitered corners.
2. Horizontal aluminum blades are spaced on 1/4" (6) centers and feature mandrel tube construction. Blade core is secured by a minimum of four sliding friction latches and is removable without the need for special tools. Optional rear directional vanes are extruded aluminum 'teardrop' profile on 3/4" (19) centers.
3. Opposed blade damper on registers features corrosion resistant steel construction and a screwdriver slot operator.

4. Minimum size is 6" x 4" (152 x 102). Maximum size is 48" x 24" (1219 x 610). Available in 1" (25) nominal increments. Blades always run parallel to width (first specified dimension). Larger sizes are supplied as multiple single sections to suit.
5. Type N standard fastening is with sheet metal screws through neck of grille frame while core is removed, providing a clean, architectural appearance.
6. Standard finish is AW Appliance White.

OPTIONS:

1. Finish:
 - SP Special _____
2. Fastening:
 - Type A External countersunk screw holes on frame margin.
3. OAL Aluminum opposed blade damper.

SCHEDULE TYPE:
PROJECT:
ENGINEER:
CONTRACTOR:

Dimensions are in inches (mm).

DATE	B SERIES	SUPERSEDES	DRAWING NO.
2 - 1 - 11	51RC	20 - 4 - 99RR	51RC-1