

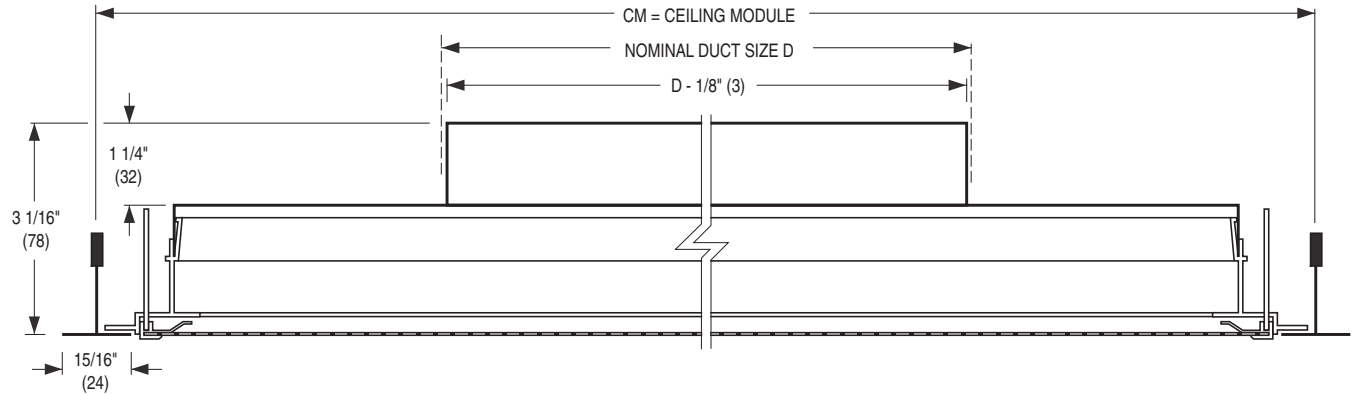

**PERFORATED CEILING DIFFUSER**  
 RETURN • PREMIUM ARCHITECTURAL QUALITY  
 ROUND OR SQUARE NECK  
**MODELS: 4330R, 4330RA**

**TYPE L Lay-in T-Bar**



**Available Combinations of Ceiling Module vs. Neck Size**

| Ceiling Module CM |                | Nominal Duct Size D            |   |  |  |
|-------------------|----------------|--------------------------------|---|--|--|
| Imperial Modules  | Metric Modules | Round Neck                     |   | Square Neck  |  |
|                   |                | Imperial Units (inches)        | Metric Units (mm)                           | Imperial Units (inches)  | Metric Units (mm)  |
| 12 x 12           | 300 x 300      | 5, 6, 7, 8                     | 127, 152, 178, 203                          | 6 x 6, 8 x 8   | 152 x 152, 203 x 203   |
| 16 x 16           | 400 x 400      | 5, 6, 7, 8, 10, 12             | 127, 152, 178, 203, 254, 305                | 6 x 6, 8 x 8, 10 x 10, 12 x 12   | 152 x 152, 203 x 203, 254 x 254, 305 x 305   |
| 24 x 12           | 600 x 300      | 5, 6, 7, 8                     | 127, 152, 178, 203                          | 6 x 6, 8 x 8, 18 x 6   | 152 x 152, 203 x 203, 457 x 152  |
| 20 x 20           | 500 x 500      | 5, 6, 7, 8, 10, 12, 14         | 127, 152, 178, 203, 254, 305, 356           | 6 x 6, 8 x 8, 10 x 10, 12 x 12, 14 x 14, 15 x 15, 16 x 16                            | 152 x 152, 203 x 203, 254 x 254, 305 x 305, 356 x 356, 381 x 381, 406 x 406                                  |
| 24 x 24           | 600 x 600      | 5, 6, 7, 8, 10, 12, 14, 15, 16 | 127, 152, 178, 203, 254, 305, 356, 381, 406 | 6 x 6, 8 x 8, 10 x 10, 12 x 12, 14 x 14, 15 x 15, 16 x 16, 18 x 18, 20 x 20, 22 x 22 | 152 x 152, 203 x 203, 254 x 254, 305 x 305, 356 x 356, 381 x 381, 406 x 406, 457 x 457, 508 x 508, 559 x 559 |

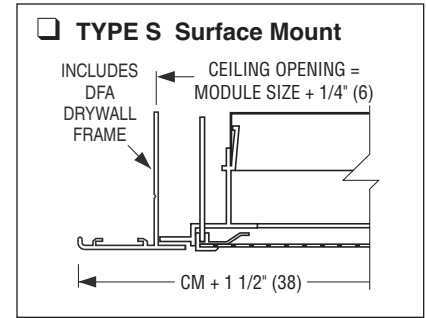

**DESCRIPTION:**

1. Material: Extruded aluminum border frame. Corrosion-resistant steel perforated face and back pan.
2. Designed to match supply air Model 4330 in appearance, except that the air pattern controllers are omitted. The diffuser features a mitered corner aluminum frame that encapsulates the perforated face providing a narrow, visible border within the T-bar module. This version is for ducted return applications; for connection to flexible or rigid round or square duct.
3. Removable face has quick release spring latches for easy access to optional damper.
4. Perforated face has 3/16" (5) diameter holes on 1/4" (6) staggered centers.
5. Standard finish is AW Appliance White.

**OPTIONS:**

- Aluminum perforated face/steel backpan. (Model 4330RA).  
Finish:
- BA Black back pan with Appliance White face.
- SP Special \_\_\_\_\_.

|                       |             |                                |                   |                    |  |
|-----------------------|-------------|--------------------------------|-------------------|--------------------|--|
| <b>SCHEDULE TYPE:</b> |             | Dimensions are in inches (mm). |                   |                    |  |
| <b>PROJECT:</b>       |             |                                |                   |                    |  |
| <b>ENGINEER:</b>      | <b>DATE</b> | <b>B SERIES</b>                | <b>SUPERSEDES</b> | <b>DRAWING NO.</b> |  |
| <b>CONTRACTOR:</b>    | 2 - 6 - 17  | 4300                           | 3 - 10 - 16       | 4330R-2            |  |