

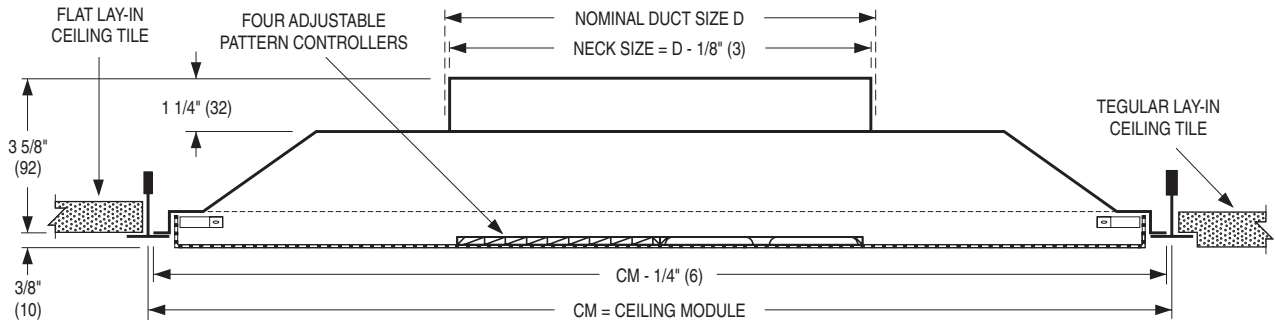

PERFORATED CEILING DIFFUSERS

SUPPLY • DROP FACE • FACE MOUNTED DEFLECTORS
 1, 2, 3 OR 4-WAY • ADJUSTABLE DISCHARGE
 MODELS: 4325, 4325A, 4325AA

TYPE L Lay-in



Available Combinations of Ceiling Module vs. Neck Size

Ceiling Module CM		Nominal Duct Size D			
Imperial Modules	Metric Modules	Round Neck		Square Neck	
		Imperial Units (inches)	Metric Units (mm)	Imperial Units (inches)	Metric Units (mm)
12 x 12	300 x 300	6, 8	152, 203	6 x 6, 8 x 8	152 x 152, 203 x 203
16 x 16	400 x 400	6, 8, 10, 12	152, 203, 254, 305	6 x 6, 8 x 8, 10 x 10, 12 x 12	152 x 152, 203 x 203, 254 x 254, 305 x 305
24 x 12	600 x 300	6, 8	152, 203	6 x 6, 8 x 8, 18 x 6	152 x 152, 203 x 203, 457 x 152
20 x 20	500 x 500	6, 8, 10, 12, 14	152, 203, 254, 305, 356	6 x 6, 8 x 8, 10 x 10	152 x 152, 203 x 203, 254 x 254
24 x 24	600 x 600	6, 8, 10, 12, 14, 15, 16	152, 203, 254, 305, 356, 381, 406	6 x 6, 8 x 8, 10 x 10, 12 x 12, 14 x 14	152 x 152, 203 x 203, 254 x 254, 305 x 305, 356 x 356
48 x 24	1200 x 600				

DESCRIPTION:

1. Material: Corrosion-resistant steel.
2. When Type L is used in a suspended T-Bar ceiling system with tegular ceiling tiles, the 3/8" (10) drop face on the diffuser, is level with the bottom of the ceiling tile, which improves the architectural appearance and performance. Discharge pattern can adjust to 1, 2, 3 or 4-way horizontal, before or after installation. Discharge pattern is adjusted by dropping the perforated face and rotating the pattern deflectors. Diffusers are shipped from the factory with a 4-way discharge pattern.
3. Hinged, removable face for easy access to core and optional damper.
4. Perforated face has 3/16" (5) diameter holes on 1/4" (6) staggered centers (51% free area).
5. Excellent performance in VAV systems.
6. Standard finish is AW Appliance White.

OPTIONS:

- Aluminum perforated face/steel backpan. (Model 4325A).
- Aluminum perforated face and backpan. (Model 4325AA).
- EX External Foil-Back Insulation, installed - R-4.2 (24 x 24 max.)
- EXB External Foil-Back Insulation, ships loose - R-4.2 (24 x 24 max.)
- MIB Molded Insulation Blanket - R-6.0 (24 x 24 only)

Finish:

- BA Black back pan and deflectors with Appliance White face.
- SP Special _____.

TYPE S Surface Mount

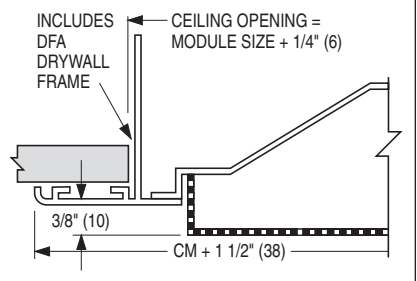

TYPE SP Spline

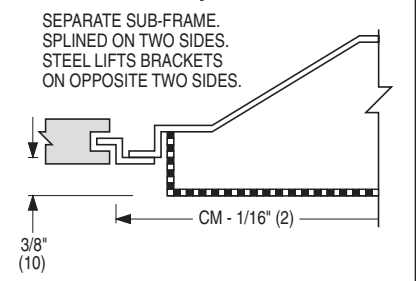

TYPE M Metal Pan (Snap-in)

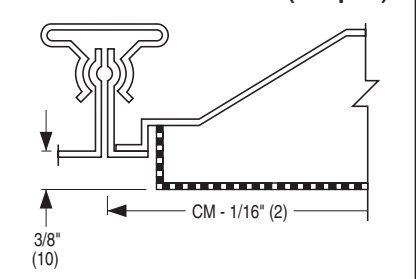

Dimensions are in inches (mm).

SCHEDULE TYPE:					
PROJECT:					
ENGINEER:	DATE	B SERIES	SUPERSEDES	DRAWING NO.	
CONTRACTOR:	8 - 7 - 19	4300	3 - 28 - 16	4325	