

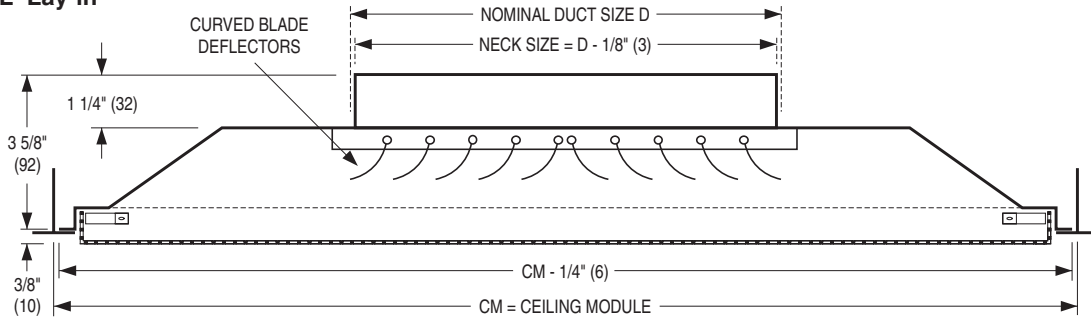

PERFORATED CEILING DIFFUSERS
CURVED BLADE • SUPPLY • DROP FACE
4-WAY ADJUSTABLE DISCHARGE PATTERN
MODELS: 4325CB, 4325CBA, 4325CBAA

TYPE L Lay-in



Available Combinations of Ceiling Module vs. Neck Size

Ceiling Module CM		Nominal Duct Size D			
Imperial Modules	Metric Modules	Round Neck		Square Neck	
		Imperial Units (inches)	Metric Units (mm)	Imperial Units (inches)	Metric Units (mm)
12 x 12	300 x 300	6, 8	152, 203	6 x 6, 8 x 8	152 x 152, 203 x 203
16 x 16	400 x 400	6, 8, 10, 12	152, 203, 254, 305	6 x 6, 8 x 8, 10 x 10, 12 x 12	152 x 152, 203 x 203, 254 x 254, 305 x 305
24 x 12	600 x 300	6, 8	152, 203	6 x 6, 8 x 8	152 x 152, 203 x 203
20 x 20	500 x 500	6, 8, 10, 12, 14	152, 203, 254, 305, 356	6 x 6, 8 x 8, 10 x 10, 12 x 12	152 x 152, 203 x 203, 254 x 254, 305 x 305
24 x 24	600 x 600	6, 8, 10, 12, 14, 15, 16, 18	152, 203, 254, 305, 356, 381, 406, 457	6 x 6, 8 x 8, 10 x 10, 12 x 12, 14 x 14, 15 x 15, 16 x 16, 18 x 18	152 x 152, 203 x 203, 254 x 254, 305 x 305, 356 x 356, 381 x 381, 406 x 406, 457 x 457

DESCRIPTION:

1. Material: Corrosion-resistant steel.
2. Discharge pattern adjustable from horizontal to vertical.
Blades are individually adjustable. Standard diffuser has a 4-way (B4) discharge pattern.
3. Hinged, removable face for easy access to core and optional damper.
4. Perforated face has 3/16" (5) diameter holes on 1/4" (6) staggered centers (51% free area).
5. Excellent performance in VAV systems.
6. Standard finish is AW Appliance White.

OPTIONS:

- Aluminum perforated face/steel backpan. (Model 4325CBA).
- Aluminum perforated face and backpan. (Model 4325CBAA).
- EX External Foil-Back Insulation, installed - R-4.2 (24 x 24 max.)
- EXB External Foil-Back Insulation, ships loose - R-4.2 (24 x 24 max.)
- MIB Molded Insulation Blanket - R-6.0 (24 x 24 only)

Finish:

- BA Black back pan and deflectors with Appliance White face.
- SP Special _____.

Blow Pattern:

- B3 3-way
- B2 2-way opposite
- C2 2-way corner
- B1 1-way

TYPE S Surface Mount

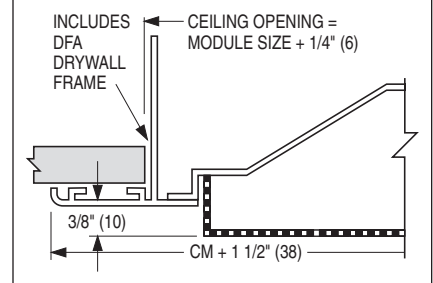

TYPE SP Spline

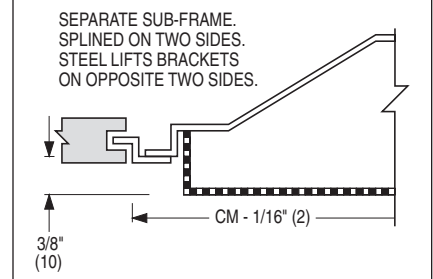

TYPE M Metal Pan (Snap-in)

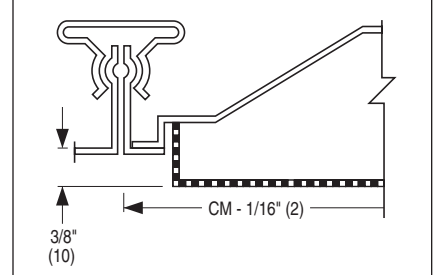

SCHEDULE TYPE:

PROJECT:

ENGINEER:

CONTRACTOR:

Dimensions are in inches (mm).

DATE

B SERIES

SUPERSEDES

DRAWING NO.

8 - 7 - 19

4300

3 - 28 - 16

4325CB