

Model 1900CB is a heavy duty industrial counterbalanced backdraft damper designed to prevent the backflow of air while allowing for automatic air intake or exhaust in industrial HVAC or process air systems. Features include a rugged vee blade design, heavy duty blade linkage and ball bearings, that provide smooth, rattle-free operation at velocities of up to 3000 fpm (15 m/s). The counterweight is easily adjusted for desired opening pressure and the heavy duty flanged frame, with optional bolt holes, connects easily to flanged duct for fast, secure installation. Durable steel construction and a wide selection of options make Model 1900CB a versatile, solid performer.

STANDARD CONSTRUCTION:

- Frame:** 8" x 2" x 14 ga. (203 x 51 x 2) coated steel channel.
- Blades:** 7" (178) wide maximum, 16 ga. (1.6) galvanized steel, vee blade design.
- Linkage:** Heavy duty linkage arms and plated steel tie bar, concealed out of the airstream.
- Axles:** 1/2" (13) dia. plated steel.
- Bearings:** Ball bearing type, pressed into frame.
- Counter-**
- Balance:** Adjustable, externally mounted.
- Finish:** Mill galvanized.

Sizes (Duct W x H):

Minimum	Maximum
Single Section	Single Section
6" x 6" (152 x 152)	48" x 96" (1219 x 2438)

Note: For larger sizes, contact factory.

Model 1900CB - Maximum Performance Ratings	
Maximum Velocity	3000 fpm (15 m/s)
Maximum Pressure	10 in. w.g. (2.5 kPa)
Maximum Temperature	250°F (121°C)

Note: For higher operating temperatures, contact factory.

OPTIONS:

- 304 Type 304 Stainless Steel construction
- 316 Type 316 Stainless Steel construction
- AS50 Type 304 Stainless Steel axles only
- BEBR External bolt-on ball bearings, relubricable
- BS Stainless Steel sleeve bearings (pressed in)
- BPV PVC blade seals (up to 180°F [83°C])
- BSE EPDM blade seals (up to 250°F [121°C])
- BSS Silicone blade seals (up to 400°F [204°C])
- JSNP Neoprene jamb seals (up to 250°F [121°C])
- F15-F40 Non-standard flange width (1 1/2" [38] to 4" [102])
Specify _____.
- BH1 Bolt holes in one flange
- BH2 Bolt holes in both flanges
- CBI Internal counterbalance
- Special Features: _____.

Note: For variations not shown, contact factory.

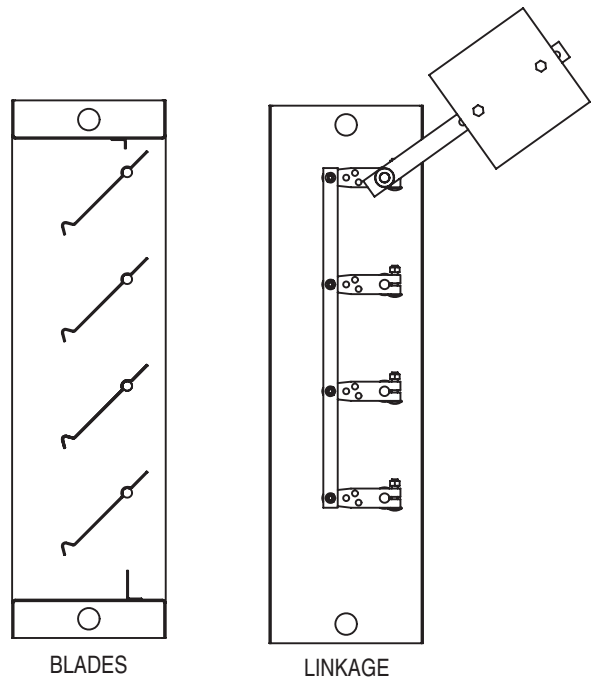
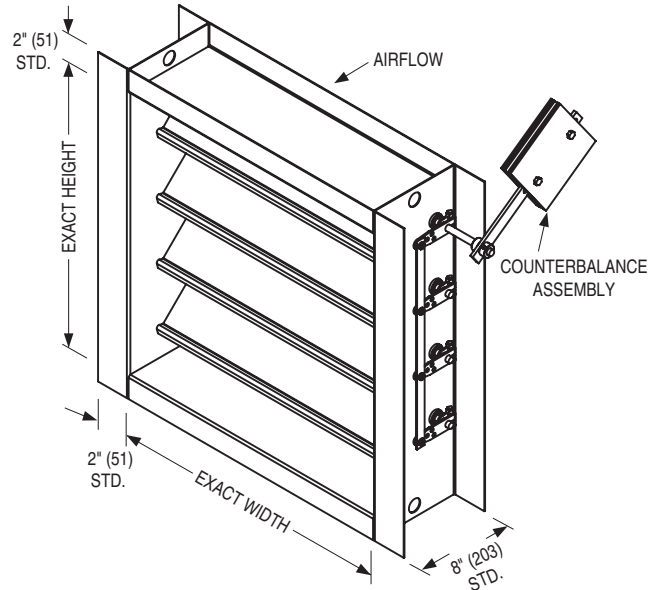

SCHEDULE TYPE:
PROJECT:
ENGINEER:
CONTRACTOR:

DATE	B SERIES	SUPERSEDES	DRAWING NO.
8 - 18 - 20	1900	6 - 30 - 14	1900CB



**HEAVY DUTY INDUSTRIAL BACKDRAFT DAMPER
COUNTERBALANCED • STEEL • VEE BLADE
PERFORMANCE DATA
MODEL: 1900CB**

PERFORMANCE LIMITATIONS:

Damper Width	Model 1900CB	
	Max. System Pressure	Max. System Velocity
48" (1219)	4.0 in. w.g.	3000 fpm
36" (914)	6.0 in. w.g.	3000 fpm
24" (610)	8.0 in. w.g.	3000 fpm
12" (305)	10.0 in. w.g.	3000 fpm

Pressure and velocity limitations shown are guidelines for design purposes. Although ratings are on the conservative side, contact Nailor for requirements beyond limitations shown.

LEAKAGE:

Damper Width	Model 1900CB			
	Leakage w/o Seals		Leakage with Seals	
	CFM per Sq. Ft.	% of Max. Flow	CFM per Sq. Ft.	% of Max. Flow
48" (1219)	39.00	1.30	14.00	0.46
36" (914)	49.00	1.63	15.00	0.50
24" (610)	60.00	2.00	17.00	0.57
12" (305)	99.00	3.30	20.00	0.67

Leakage data is based upon a pressure differential of 1 in. w.g., tested in accordance with AMCA Standard 500-D.

PRESSURE DROP: SIZE: 36" x 36" (914 x 914)

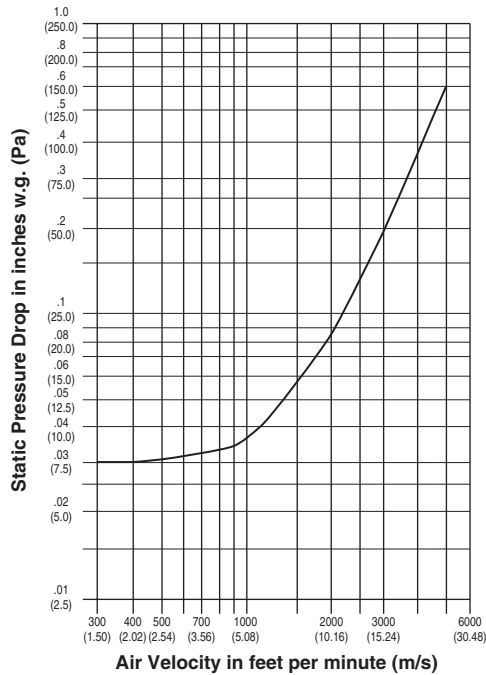

Tested per AMCA Standard 500-D using test set-up Figure 5.3, ductwork upstream and downstream.

SCHEDULE TYPE:	Page 2 of 2			
PROJECT:	Dimensions are in inches (mm).			
ENGINEER:	DATE	B SERIES	SUPERSEDES	DRAWING NO.
CONTRACTOR:	8 - 18 - 20	1900	6 - 30 - 14	1900CB