



**TUNNEL CORRIDOR OR COMBINATION  
FIRE/SMOKE DAMPER  
VEE GROOVE BLADE  
MODEL: 1271C-3**

**QUALIFICATIONS:**

- **UL 555 CLASSIFIED CORRIDOR DAMPER, 1 hr. Fire Resistance Rating (File #9492).**
- **UL 555 CLASSIFIED FIRE DAMPER, 1 1/2 hr. Fire Resistance Rating (File #9492).**
- **UL 555S CLASSIFIED SMOKE DAMPER, Class I or II at 250°F or 350°F elevated temp. (File #9492).**
- **California State Fire Marshal Listing No. 3225-0935:106.**
- **Meets the requirements of NFPA 90A, NFPA 92A for Fire/Smoke Dampers.**
- **Meets the requirements of City of Los Angeles, Uniform Building Code.**
- **Maximum velocity 2000 fpm @ 4" w.g. (up to 4000 fpm @ 8" w.g. with specific actuators. Consult Nailor).**

Model 1271C-3 is both a 1 hr. rated corridor damper for use in corridor ceilings and a standard 1 1/2 hr. rated combination fire/smoke damper for use in walls and floors. The dual rating makes it ideal for stocking as the unit can be supplied when either type of damper is required by the local customer. Model 1271C-3 is supplied complete with upper retaining angles as well as mounting tabs for use with a steel grille/diffuser. The damper may be installed using the single-side retaining angles method. Lower retaining angles are available for ducted corridor or standard wall/floor combination fire/smoke applications when the two-sided angles installation is utilized.

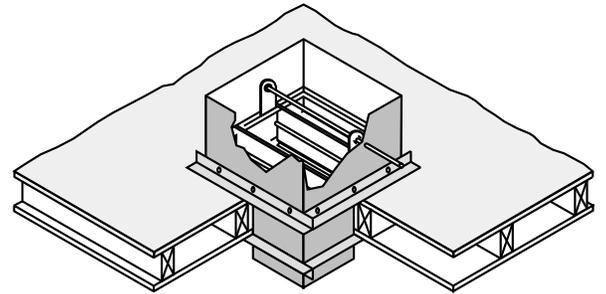

**STANDARD SPECIFICATION:**

- Frame:** 5" x 7/8" x 16 ga. (127 x 22 x 1.6) galvanized steel hat channel.
- Blades:** 6" (152) wide on 5 1/2" (140) centers. 16 ga. (1.6) galvanized vee groove or double-skin design.
- Sleeve:** 16" x 20 ga. (406 x 1.0) standard.
- Upper Retaining Angles:** 1 1/2" x 1 1/2" x 16 ga. (38 x 38 x 1.6) galvanized steel (by Nailor).
- Lower Retaining Angles:** 1 1/2" x 1 1/2" x 16 ga. (38 x 38 x 1.6) galvanized steel by installing contractor (optionally by Nailor) when required.
- Linkage:** Concealed in frame.
- Bearings:** 1/2" (13) dia. self-lubricating oilite bronze.
- Axles:** 1/2" (13) dia. plated steel double bolted to blades.
- Jamb Seals:** Cambered stainless steel.
- Blade Seals:** Stainless steel on vee groove blade.
- Heat Responsive Device (Controlled Closure):**  
250°F (121°C) std. 165°F (74°C), 212°F (100°C) and, with ERL only, 350°F (176°C) available.  
ERL (Electric Resettable Link) is standard on all dampers with electric actuators. PRL (Pneumatic Replaceable Link) is standard on all dampers with pneumatic actuators.
- Minimum Size:** 8" x 8" (203 x 203).
- Maximum Size:** 24" x 24" (610 x 610).

**LEAKAGE CLASS / ELEVATED TEMPERATURE:**

- I     II    @ 250°F (Standard)  
 I     II    @ 350°F (Optional)

**ACTUATOR SELECTION:**

- Electric**     **Pneumatic** Model \_\_\_\_\_ .

Actuators are mounted for Fail Closed (Normally Closed) operation in accordance with code requirements.

**ACTUATOR LOCATION:**

- Out of airstream     In the airstream

**OPTIONS:**

- MLS-300** Position indicator switch pack.
- MLS-400** Electric Fire Sensor (Re-openable control system). Includes dual heat sensors (165°F and 250°F or 350°F) and position indicator switch pack.
- Factory mounted upper retaining angles.**
- Lower retaining angles by Nailor.** (Shipped loose for field attachment).
- Special Features.**  
Specify: \_\_\_\_\_ .

For installation instructions, see IOM-TCFSDINST (Tunnel Corridor damper) or IOM-1270INST (Combination Fire/Smoke damper).

For supplementary installation instructions for Single-Side Retaining Angles see IOM-FDSSRAINST.

**SCHEDULE TYPE:**

**PROJECT:**

**ENGINEER:**

**CONTRACTOR:**

Page 1 of 2  
Dimensions are in inches (mm).

DATE	B SERIES	SUPERSEDES	DRAWING NO.
6 - 16 - 16	1270C	12 - 19 - 05	1270C-3

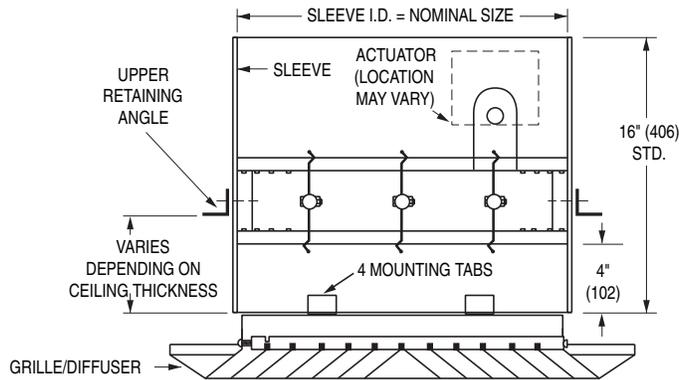
**MODEL 1271C-3 APPLICATIONS:**
**TUNNEL CORRIDOR DAMPER WITH STEEL GRILLE/DIFFUSER:**

For installation instructions see IOM-TCFSDINST.

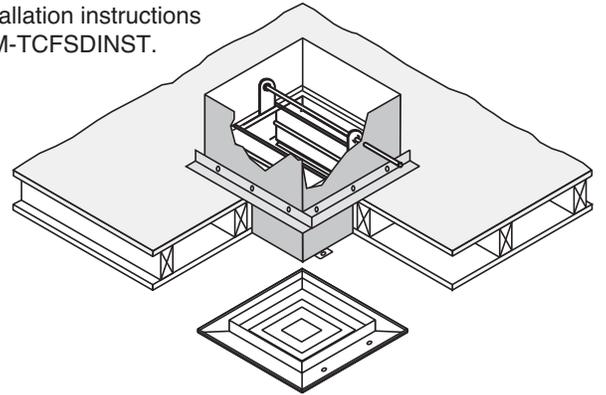
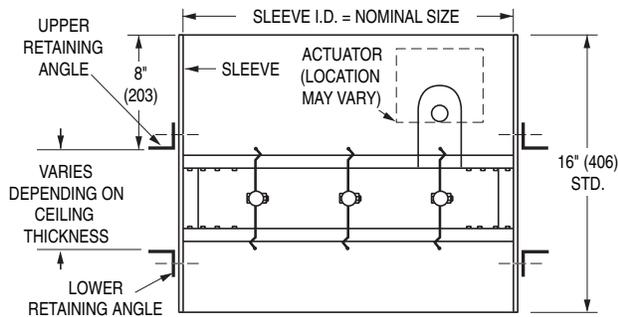
**TUNNEL CORRIDOR DAMPER FOR DUCTED INSTALLATIONS:**

For installation instructions see IOM-TCFSDINST.

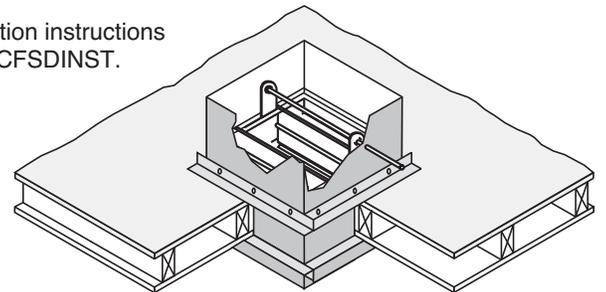
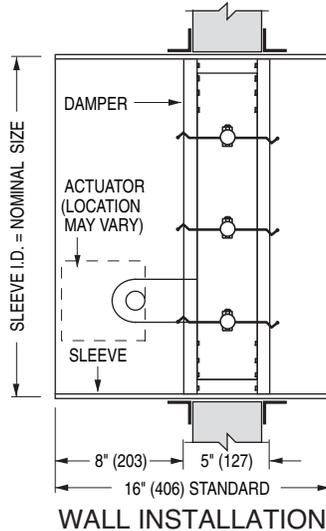
**COMBINATION FIRE/SMOKE DAMPER FOR WALLS AND FLOORS:**

For installation instructions see IOM-1270INST.

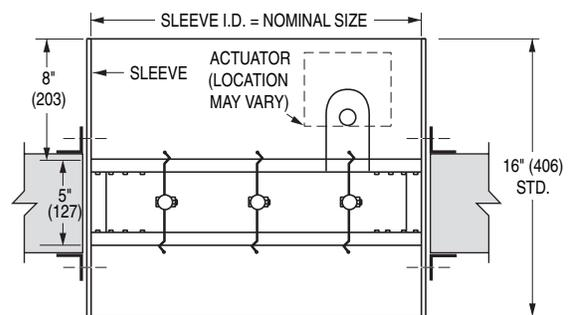

FLOOR INSTALLATION

**SCHEDULE TYPE:**
**PROJECT:**
**ENGINEER:**
**CONTRACTOR:**

 Page 2 of 2  
 Dimensions are in inches (mm).

**DATE**
**B SERIES**
**SUPERSEDES**
**DRAWING NO.**

6 - 16 - 16

1270C

12 - 19 - 05

1270C-3