

# COVID-19

## MEETING THE NEED FOR COVID-19 PATIENT ISOLATION ROOMS WITH REVERSE FLOW FAN FILTER UNITS

### MODELS: 92FFU-RF AND 92FFUM-RF

According to the ASHRAE Standard 170, all Airborne Infection Isolation (AII) rooms should be kept at a negative static pressure at all times to prevent the spread of infected air to the rest of the building. To accomplish this, the exhaust air should be filtered and exceed the supply air. However, in most cases, the central exhaust will not be able to accommodate HEPA filtration. Therefore, using a Reverse Flow Fan Filter Unit (FFU) with HEPA filter can keep the room at negative pressure and decontaminate the exhaust air at the same time.

Nailor has played an important role in helping hospitals provide critical environment patient isolation care – from the Ebola outbreak of 2014 to the current COVID-19 pandemic – with our Critical Environment products.

Nailor's Reverse Flow - Fan Filter Units are available in both ceiling-mounted and portable models, making it easier to quickly convert existing spaces into patient isolation rooms.

Our Reverse Flow FFU's create negative pressure environments that remove the air from an isolation room and clean it via the unit's built-in HEPA filter, which keeps airborne contaminants from escaping the room. These units are the most powerful available, featuring...

- The industry's highest output, up to 1125 CFM
- Energy efficiency (only 65 watts at 90 FPM velocity/450 CFM)
- Quiet performance (only 45 DBA at 90 FPM, 58 DBA at 1100 CFM)
- Ceiling-mount version has the industry's lowest plenum height – just 16" for easier retrofits
- Standard and High Flow HEPA and ULPA filter options
- Ducted and non-ducted versions are available

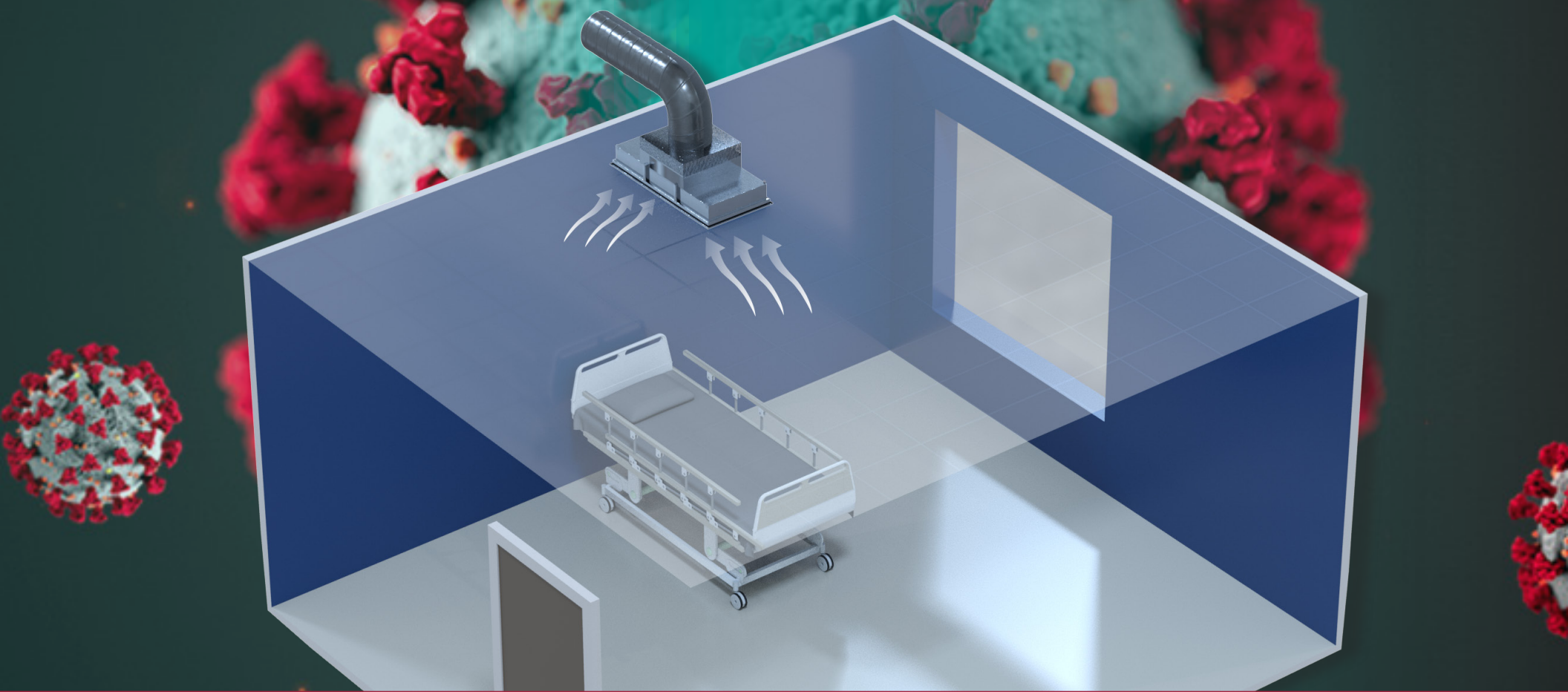

### Ceiling-Mounted Reverse Flow Fan Filter Unit • 92FFU-RF

Ceiling-mounted units are a perfect option for buildings with centralized exhaust systems.

Nailor Ceiling-Mounted Reverse Flow Fan Filter Unit is installed in the ceiling of the isolation room directly above the patient bed. The unit may be connected to the existing exhaust/return ductwork, creating a negative pressure environment that prevents airborne contaminants from escaping. Air is passed through the unit's HEPA filter, cleaned and decontaminated during this process.

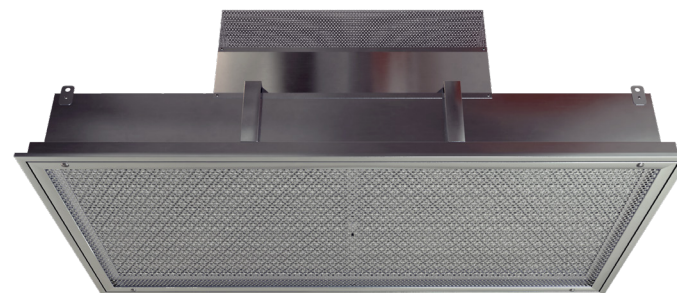



### Reverse Flow Fan Filter Mobile Unit • 92FFUM-RF

Due to the increased number of Coronavirus patients and potential bed shortage, the need for converting existing beds or patient treatment wings to private rooms with negative pressure is rising. To accomplish this, a portable fan filter unit with HEPA filter can be used to quickly create a negative pressure room and decontaminate the exhaust air.

Nailor Reverse Flow Fan Filter mobile unit can be plugged into a standard electrical wall outlet and placed anywhere on the floor of the isolation room. It draws air in, then exhausts HEPA filtered air out through ductwork connected to a room exhaust return grille, wall or through a window. Openings for ductwork must be sealed to prevent leakage and maintain room pressurization. The unit features a push/pull handle and swivel casters for easy movement.



### Standard Fan Filter Mobile Unit • 92FFDM

Not only Nailor reverse flow units, but also standard forward flow FFU's can be useful. For situations where the room does not have exhaust duct work or a window connected to the outside, the standard unit can be used.

This portable version of our standard Fan Filter Unit with HEPA filter draws air through the back of the unit and discharges HEPA filtered air through the face, continually re-circulating and filtering the air in the room. This unit plug into a standard electrical wall outlet and can also be placed in a sealed opening or doorway between two adjacent rooms, such as hotel rooms, to quickly create a negative pressure patient isolation space.

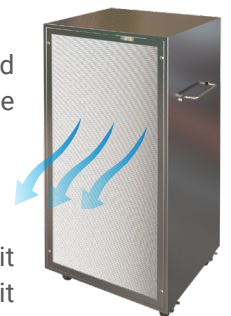

## Model 92FFU-RF • Ceiling-Mounted Reverse Flow Fan Filter Unit

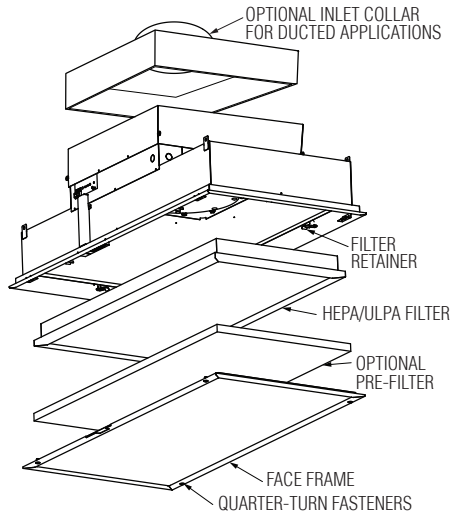
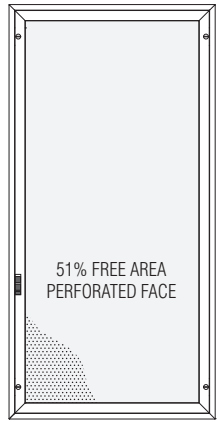

### DESCRIPTION:

Nailor 92FFU-RF Ceiling-Mounted Reverse Flow Fan Filter Units have been designed to create a negative pressure environment and pull contaminants from the desired area. These units are intended to be used in modular cleanrooms, cleanroom garmenting rooms, healthcare contamination control, cleanroom workstations, clean workbench enclosures, and associated air hoods.

ECM technology provides an ultra-energy efficient design with the ability to precisely set a constant air volume. As filter loading increases fan external static pressure, the ECM will compensate to maintain set airflow. Filters are secured within the plenum against a continuous knife edge that contacts the gel channel of the filter, providing a leak proof seal. Filters are protected by a perforated face, room-side-removable via quarter-turn fasteners.

### STANDARD FEATURES:

- 304 Stainless steel frame and perforated face with 3/16" (5) dia. holes on 60° 1/4" (6) staggered centers (51% free area). The face plate is removable for cleaning, filter replacement and is secured by 1/4 turn fasteners.
- 304 Stainless Steel fully welded plenum.
- Heavy duty hanger brackets.
- LED fan operation indicator (on during normal operation).

- Room side Accessible Motor and controls.
- Two Stainless Steel safety cables to prevent accidental dropping of removable face.
- High Efficiency ECM for precise constant airflow and field balancing. Available: 120V/1PH/60Hz, 208V/1PH/60Hz, 240V/1PH/60Hz and 277V/1PH/60Hz.
- Face adjustable airflow control.
- Face accessible SPP.
- Standard HEPA filter (99.99% on 0.3 µm).
- QF Toggle disconnect switch.

### EC MOTOR PROGRAM:

- Constant Flow.
- Constant Torque.

### OPTIONS:

- High capacity HEPA filter.
- Standard ULPA filter (99.9995% on 0.12 µm).
- High capacity ULPA filter.
- Loaded filter indicator.
- MERV 8 pre-filter.
- Filter by others.
- 10" (254), 2" (305) or 14" (356) duct collar.

### Finish:

- Appliance White.
- #4 Brushed Satin Polished finish.

## Model 92FFUM-RF • Reverse Flow Fan Filter Mobile Unit

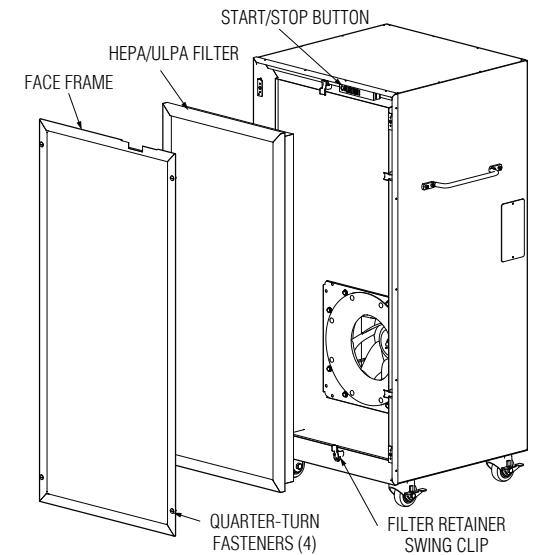
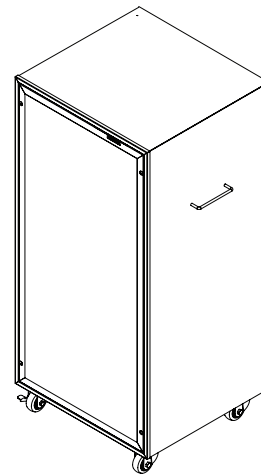

### DESCRIPTION:

Nailor 92FFUM-RF Reverse Flow Fan Filter Mobile Units have been designed to create a negative pressure environment and pull contaminants from the desired area. This portable version fan filter unit plugs into a standard electrical wall outlet and can be placed anywhere on the floor of the isolation room.

ECM technology provides an ultra-energy efficient design with the ability to precisely set a constant air volume. As filter loading increases fan external static pressure, the ECM will compensate to maintain set airflow.

Filters are secured within the plenum against a continuous knife edge that contacts the gel channel of the filter, providing a leak proof seal. Filters are protected by a perforated face, room-side removable via quarter-turn fasteners.

### STANDARD FEATURES:

- 304 Stainless Steel fully welded cabinet. (51% free area). The face plate is removable for cleaning, filter replacement and is secured by 1/4 turn fasteners.
- LED fan operation indicator (on during normal operation).
- Standard HEPA filter (99.99% on 0.3 µm). High Efficiency ECM for precise constant airflow and field balancing. Available:

120V/1PH/60Hz, 208V/1PH/60Hz, 240V/1PH/60Hz and 277V/1PH/60Hz.

- 12" (305) dia. outlet collar.
- Toggle disconnect switch.
- Face adjustable airflow control.
- Face accessible SPP.
- Push/Pull Handle.
- 4 Swivel Casters - (2) with Brakes.
- 10 Ft. Hospital Grade Cord with Plug.

### EC MOTOR PROGRAM:

- Constant Flow.
- Constant Torque.

### OPTIONS:

- High capacity HEPA filter.
- Standard ULPA filter (99.9995% on 0.12 µm).
- High capacity ULPA filter.
- Loaded filter indicator.
- MERV 8 pre-filter.
- 14" (356) duct collar.

### Finish:

- Appliance White.
- #4 Brushed Satin Polished finish.